

低阻分流器贴片电阻规格书-RZ 系列

Specification Low-Resistance Shunt Chip Resistors-Type *RZ series*

规格书

SPECIFICATION

DGPHI
— 華年 —
电话: 0755-23173910

丽智电子（昆山）有限公司

地址：江苏省昆山市汉浦路 989 号

Address: No. 989, Hanpu Road Kunshan City Jiangsu Province

Tel:0086-0512-57780531

Fax:0086-0512-57789581

丽智电子（南通）有限公司

地址：江苏省南通市通州区康富路 789 号

Address: No. 789, Kang Fu Road Tongzhou District Nantong city Jiangsu province

Tel: 0086-0513-68856666

Fax: 0086-0513-68383688

低阻分流器贴片电阻规格书-RZ 系列

Specification Low-Resistance Shunt Chip Resistors-Type *RZ series*

1.范围 (scope) :

1.1 适用于本公司所生产的无铅、无卤之低阻分流器合金贴片电阻 RZ 系列产品

This specification applies to Low-Resistance Shunt resistors of RZ Series which meet requirements of Pb free and halogen free.

1.2 符合 AEC-Q200 条款

The relevant provisions of the AEC-Q200

2.产品料号 (Part number) :

For example: 3920 5W 1% 1mΩ

RZ3920FRR001G

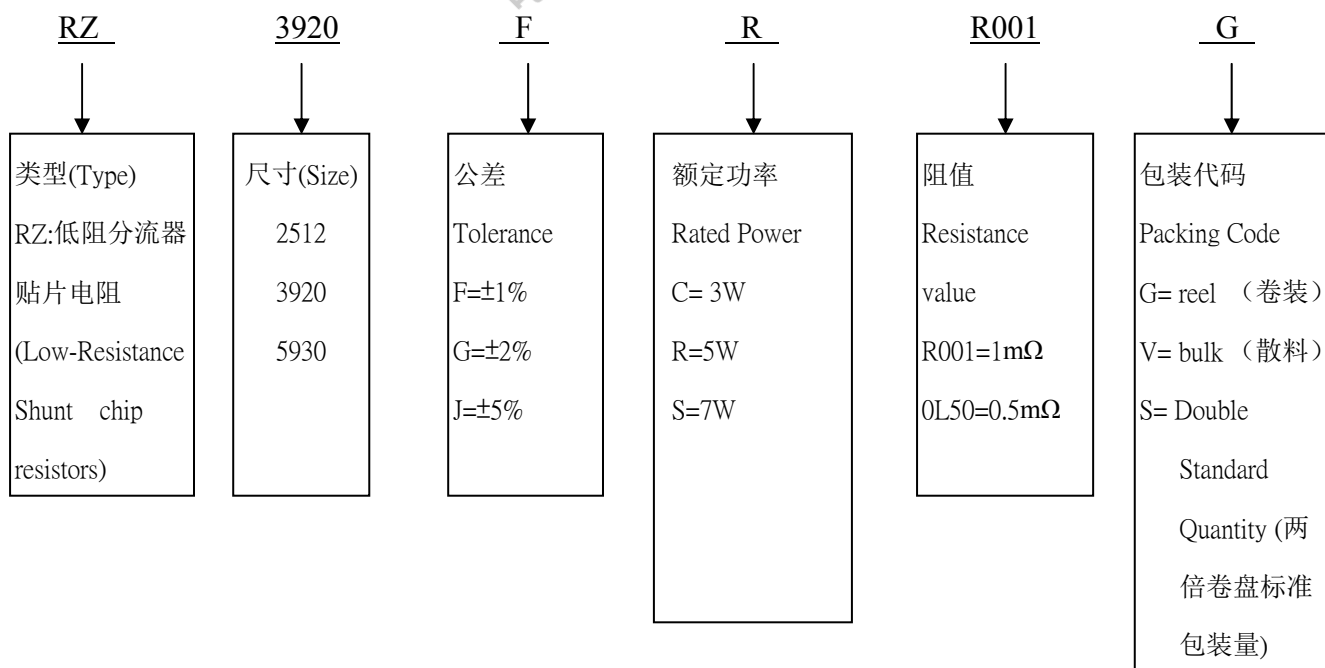

低阻分流器贴片电阻规格书-RZ 系列

Specification Low-Resistance Shunt Chip Resistors-Type *RZ series*

3.尺寸 (Dimension) :

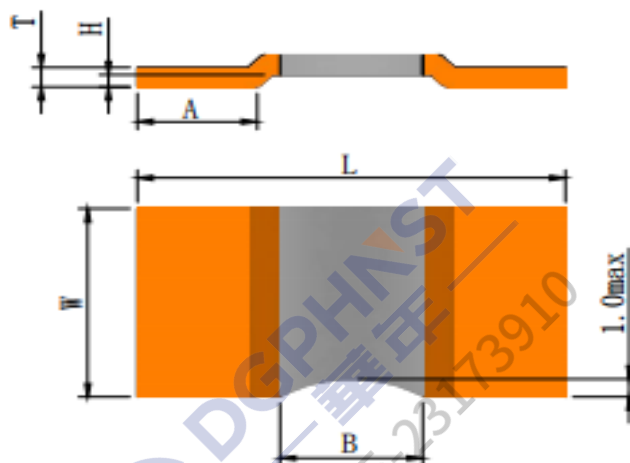

类别 Type	阻值(mΩ) Resistance	B(mm)	W(mm)	L(mm)	A(mm)	H(mm)	T(mm)
RZ2512	0.3	3.0±0.3	3.2±0.25	6.4±0.2	1.2±0.2	0.5±0.1	0.95±0.1
	0.35						0.60±0.1
	0.4						0.88±0.1
	0.5						0.85±0.1
	0.7						0.60±0.1
	1						0.42±0.1
	2						0.67±0.1
	3						0.50±0.1
	4						0.50±0.1
	5						0.50±0.1
RZ3920	0.2	4.5±0.3	5.2±0.3	10±0.2	2.0±0.2	0.5±0.1	1.66±0.1
	0.3						1.28±0.1
	0.5						0.77±0.1
	0.7						0.55±0.1
	1						1.25±0.1
	2						0.62±0.1
	3						0.42±0.1
	4						0.35±0.1
	5						0.28±0.1

低阻分流器贴片电阻规格书-RZ 系列

Specification Low-Resistance Shunt Chip Resistors-Type *RZ series*

类别 Type	阻值(mΩ) Resistance	B(mm)	W(mm)	L(mm)	A(mm)	H(mm)	T(mm)
RZ5930	0.2	5.0±0.3	7.7±0.3	15±0.2	4.2±0.2	0.5±0.1	1.50±0.1
	0.3						0.96±0.1
	0.4						0.72±0.1
	0.5						0.58±0.1
	0.75						0.39±0.1
	0.8						0.36±0.1
	1						0.94±0.1
	2						0.48±0.1
	3						0.31±0.1

4.分流器本体字码标示(Marking on the Shunt Resistor's Body):

※ ±1%,±2%,±5%的产品，以四字码标示，第一位字码“R”标示 10^{-3} ，后三位表示阻值的有效数字。第二位字码“m”表示阻值小数点。

±1%,±2%,±5% tolerance product: the marking is 4 digits, The first letter 'R' denotes 10^{-3} , The other three digital declare resistance. The second letter 'm' mean point.。

2512



3920



5930



低阻分流器贴片电阻规格书-RZ 系列

Specification Low-Resistance Shunt Chip Resistors-Type *RZ series*

5.功率衰减曲线（Power Derating Curve）：

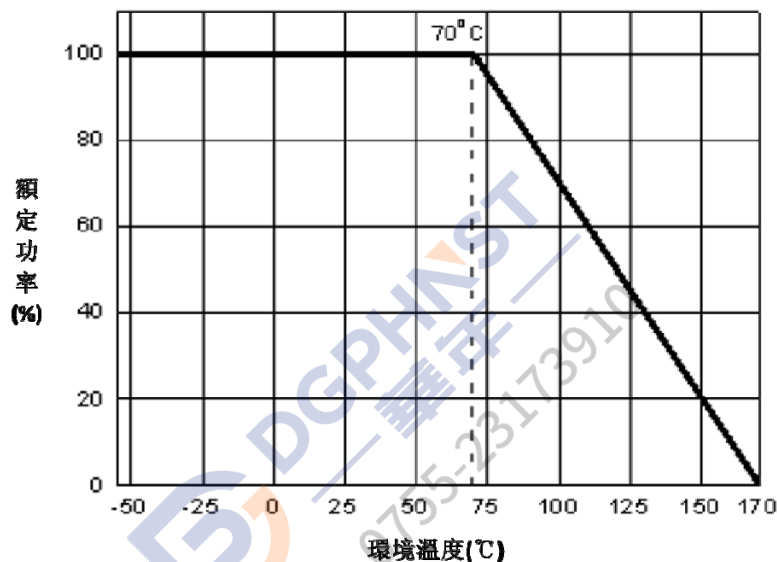

工作温度范围（Operating Temperature Range）：-55°C~+170°C；

储存条件（storage condition）：5~35°C, 40~75%RH.

保存期限(Shelf Life): 2 年

6.阻值范围及电气特性（Resistance Range and Electrical Characteristics）：

型别 Type	额定功率 Rated Power	阻值范围(mΩ) Resistance Range(mΩ)	温度特性TCR (ppm/°C)	绝缘阻抗 Insulation Resistance	操作温度 Operation Temperature
		F(±1%)、G(±2%)、J(±5%)			
RZ2512	3W	0.3、0.35、0.4、0.5、0.7、1	±150	>100MΩ	-55°C~+170°C
		2、3、4、5	±75		
RZ3920	5W	0.2、0.3、0.5、0.7	±150		
		1、2、3、4、5	±75		
RZ5930	7W	0.2、0.3、0.4、0.5、0.75、0.8	±150		
		1、2、3	±75		

低阻分流器贴片电阻规格书-RZ 系列

Specification Low-Resistance Shunt Chip Resistors-Type *RZ series*

6.1 合金材质(Material of Alloy)

类别 Type	材质 Material	阻值(mΩ) Resistance(mΩ)
RZ2512	锰铜(Manganin)	0.3
		0.35
		0.4
		0.5
		0.7
		1
	铁铬铝(FeCrAl)	2
		3
		4
		5
RZ3920	锰铜(Manganin)	0.2
		0.3
		0.5
		0.7
	铁铬铝(FeCrAl)	1
		2
		3
		4
		5
		5
RZ5930	锰铜(Manganin)	0.2
		0.3
		0.4
		0.5
		0.75
		0.8
	铁铬铝(FeCrAl)	1
		2
		3

低阻分流器贴片电阻规格书-RZ 系列

Specification Low-Resistance Shunt Chip Resistors-Type **RZ series**

备注 (remark) :

※ 额定电流计算公式 (The rated current is calculated by the following formula) :

$$I = \sqrt{P/R}$$

I: 额定电流 (Rated current) (A)

P: 额定功率 (Rated Power) (W)

R: 电阻阻值 (Resistance) (ohm)

※ 如果计算出的电流超过此型别的最大工作电流, 则此型别的最大工作电流为此电阻的额定电流。

In case the value calculated by the formula exceed the maximum working current as above table, the maximum working current shall be regarded as rated current.

低阻分流器贴片电阻规格书-RZ 系列

Specification Low-Resistance Shunt Chip Resistors-Type **RZ series**

7.性能(Performance Specifications)

内容 Item	测试方法 Test Methods	测试条件 Test Conditions	规格 Specification
温度系数 Temperature Coefficient	IEC60115-1 4.8	$TCR = (R - R_0) / (t - t_0) R_0 \times 10^6 \text{ (ppm)}$ <p> R_0 电阻在室温下的阻值(resistance at room temperature) R 电阻在 125°C 下的阻值(resistance at 125°C) t_0 室温(room temperature) t 测试温度 125°C (test temperature 125°C) </p>	参照规格表 As Spec.
高温储存 High Temperature Exposure	MIL-STD-202 Method 108	125°C 下放置 1000H, 试验结束 24±4 小时后量测试前后阻值变化率. 1000 hrs. @T=125°C. Measure the variation of resistance at 24±4 hours after test conclusion. $\Delta R\% = (R_2 - R_1) / R_1 * 100 \text{-----} (\%)$ <p> R_1 = 试验前阻值(resistance before test) R_2 = 试验后阻值(resistance after test) </p>	<±1%
低温储存 Low Temperature operation	IEC60115-1 4.23.4	-55°C 下放置 45 分钟, 后量测试前后阻值变化率. 45 min. @T=-55°C. Measure the variation of resistance after test conclusion. $\Delta R\% = (R_2 - R_1) / R_1 * 100 \text{-----} (\%)$ <p> R_1 = 试验前阻值(resistance before test) R_2 = 试验后阻值(resistance after test) </p>	<±1%
温度循环 Temperature cycling	JESD22 Method JA-104	-55°C & +125°C, 循环 1000 次, 试验结束 24±4 小时后量测试前后阻值变化率. 1000 Cycles (-55°C to +125°C) Measurement at 24±4 hours after test conclusion. Measure the variation of resistance at 24±4 hours after test conclusion. $\Delta R\% = (R_2 - R_1) / R_1 * 100 \text{-----} (\%)$ <p> R_1 = 试验前阻值(resistance before test) R_2 = 试验后阻值(resistance after test) </p>	<±1%

低阻分流器贴片电阻规格书-RZ 系列

Specification Low-Resistance Shunt Chip Resistors-Type *RZ series*

内容 Item	测试方法 Test Methods	测试条件 Test Conditions	规格 Specification
短时间过负荷 Short-time overload	IEC60115-1 4.13	加载 5 倍的额定功率, 时间 5 秒后测量试验前后的阻值变化率。 Applied 5.0 times of rated power for 5 second. Measure the variation of resistance. $\Delta R\% = (R2 - R1) / R1 * 100 \text{-----} (\%)$ R1 = 试验前阻值(resistance before test) R2 = 试验后阻值(resistance after test)	<±1%
耐湿特性 Biased Humidity	MIL-STD-202 METHOD 103	加载 10%额定功率, 85℃/85%RH, 持续通电 1000H, 试验结束 24±4 小时后进行测试 1000 hours 85℃/85%RH. Note: Specified conditions: 10% of operating power. Measurement at 24±4 hours after test conclusion. $\Delta R\% = (R2 - R1) / R1 * 100 \text{-----} (\%)$ R1 = 试验前阻值(resistance before test) R2 = 试验后阻值(resistance after test)	<±1%
负荷寿命 Operational life	MIL-STD-202 METHOD 108	电阻放入恒温箱中, 温度 70±2℃, 通电额定电流 1.5 小时, 断电 0.5 小时; 重复通断电至试验时间 1000 +48/-0 小时. 量测试验前后阻值变化率。 Put the specimen in a chamber at 70±2 °C temperature , and applied rated Current for 1.5H and rested for 0.5H repeatedly till total test time is 1000 +48/-0 .. Measure the variation of resistance. $\Delta R\% = (R2 - R1) / R1 * 100 \text{-----} (\%)$ R1 = 试验前阻值(resistance before test) R2 = 试验后阻值(resistance after test)	<±1%

低阻分流器贴片电阻规格书-RZ 系列

Specification Low-Resistance Shunt Chip Resistors-Type *RZ series*

内容 Item	测试方法 Test Methods	测试条件 Test Conditions	规格 Specification
焊锡性 Solderability	J-STD-002B test B	沾助焊剂后浸入锡炉，锡炉温度 245±5℃，时间 2~3 秒 Dip the terminal in a flux and then dip into a soldering bath at 245±5℃ for 2~3sec.	最少 95%面积上锡(Min 95% coverage)
抗焊锡热 Resistance to soldering heat	IEC60115-1 4.18	沾助焊剂后浸入锡炉，锡炉温度 260±5℃，时间 10±1 秒，测量试验前后的阻值变化率。 Dip the terminal in a flux and then dip into a soldering bath at 260±5℃ for 10±1sec. Measure the variation of resistance. $\Delta R\%=(R2-R1)/R1*100----- (\%)$ R1 = 试验前阻值(resistance before test) R2 = 试验后阻值(resistance after test)	<±1%
机械冲击 Mechanical Shock	MIL-STD-202 METHOD 213	半正弦，100g's，震动 6ms，速度 12.3 ft/s100Hz，量测试验前后阻值变化率。 100g's , Normal duration is 6ms , half sine shock pulse .Measure the variation of resistance. $\Delta R\%=(R2-R1)/R1 *100----- (\%)$ R1 = 试验前阻值(resistance before test) R2 = 试验后阻值(resistance after test)	<±1%
振动 Resistance to vibration	MIL-STD-202 METHOD 204	5g's 的力 20 分钟， 12 个循环，测试频率从 10-2000 赫兹，量测试验前后阻值变化率。 5g's for 20min.12cycles, 10-2000Hz . Measure the variation of resistance. $\Delta R\%=(R2-R1)/R1*100----- (\%)$ R1 = 试验前阻值(resistance before test) R2 = 试验后阻值(resistance after test)	<±1%

低阻分流器贴片电阻规格书-RZ 系列

Specification Low-Resistance Shunt Chip Resistors-Type **RZ series**

内容 Item	测试方法 Test Methods	测试条件 Test Conditions	规格 Specification
端子弯曲 Board Flex	AEC-Q200-005	弯曲 2mm, 60 秒, 量测试验前后阻值变化率。 Min 2mm deflection ,60sec. Measure the variation of resistance. Measure the variation of resistance.	<±1%
端子强度 Terminal Strength	AEC-Q200-006	应用 17.7N (1.8Kg), 时间 60±1 秒 Applied a 17.7N (1.8Kg) for 60±1seconds.	<±1%
冷热冲击 Thermal shock	MIL-STD-202 METHOD 107	温度-55/+125℃, 周期数是 300,设备安装。最大传输时间是 20 秒, 停留 15 分钟。 use -55/+125°C, Number of cycles is 300. Devices mounted. Maximum transfer time is 20 seconds. Dwell time is 15 minutes. Air –Air $\Delta R\%=(R2-R1)/R1*100----- (\%)$ R1 = 试验前阻值(resistance before test) R2 = 试验后阻值(resistance after test)	<±1%
ESD 试验 ESD test	AEC-Q200-002	加载规定静电电压 2KV.2 次/间隔 1 秒, Other:2KV, 2times/1s	<±1%

低阻分流器贴片电阻规格书-RZ 系列

Specification Low-Resistance Shunt Chip Resistors-Type *RZ series*

8. 包装规格 (Tapping Specification)

8.1 卷盘尺寸 (reel dimension)

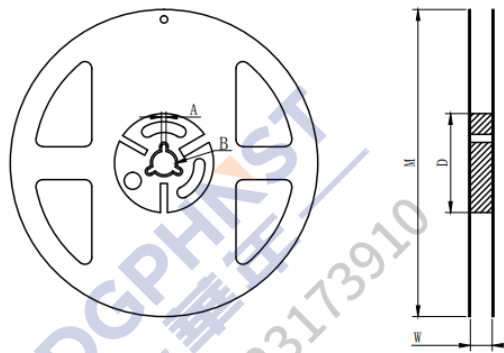

Reel Type	W(mm)	M(mm)	A(mm)	B(mm)	D(mm)
RZ2512 for 16mm tape	17.0±1.0	330±2.0	2.0±0.5	13.5±0.5	60.0±1.0
RZ3920 for 24mm tape	25.0±1.0	330±2.0	2.0±0.5	13.5±0.5	60.0±1.0
RZ5930 for 32mm tape	33.0±1.0	330±2.0	2.0±0.5	13.5±0.5	60.0±1.0

8.2 包装尺寸 (packing dimension)

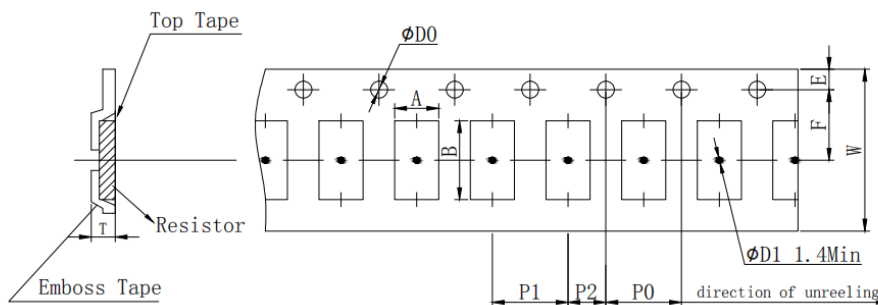

单位:mm

Type	A	B	W	E	F	P0	P1	P2	ϕD_0	T	Quantity (EA)
RZ2512	3.5±0.1	6.8±0.1	16±0.2	1.75±0.1	5.5±0.1	4.0±0.1	8.0±0.1	2.0±0.1	1.5±0.1	1.8±0.2	4000
RZ3920	5.7±0.1	11.2±0.1	24±0.2	1.75±0.1	7.5±0.1	12±0.1	12±0.1	6.0±0.1	1.5±0.1	2.5±0.2	2000
RZ5930	8.2±0.1	16.1±0.1	32±0.2	1.75±0.1	11.5±0.1	12±0.1	12±0.1	6.0±0.1	1.5±0.1	2.5±0.2	2000

低阻分流器贴片电阻规格书-RZ 系列

Specification Low-Resistance Shunt Chip Resistors-Type *RZ series*

9. 上胶带剥离力测试 (Peel force of top cover tape)

上胶带以 300mm/分钟的速度，沿 165~180 度角的方向进行剥离，如下图所示。纸带的剥离力范围为 10g~70g；载带的剥离力范围为 30~100g

The top cover tape is pulled at a speed of 300 mm/min with the angle between the tape during peel and the direction of unreeling maintained at 165 to 180 degree as following picture. The peel force of paper carrier tape shall be 0.1N to 0.7N(10 to 70 g), the peel force of plastic carrier tape shall be 0.3N to 1N (30 to 100 g)

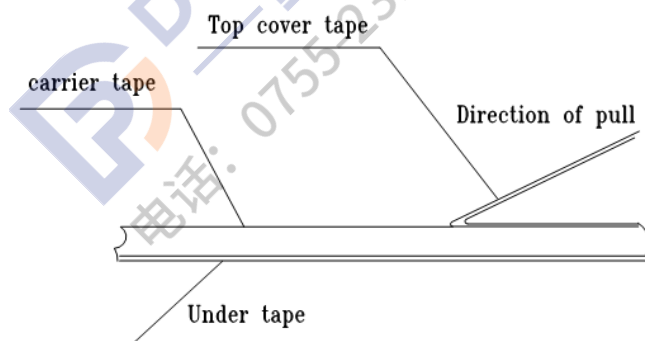

10. 焊接 (soldering)

10.1 建议焊盘尺寸 (Recommended Solder Pad Dimension)

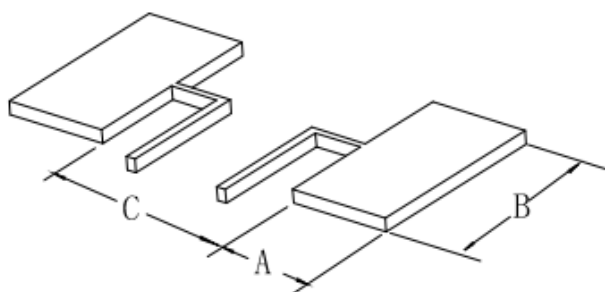

类别 Type	A(mm)	B(mm)	C(mm)
RZ2512	1.8±0.25	3.6±0.25	3.8±0.25
RZ3920	2.7±0.25	6.2±0.25	5.6±0.25
RZ5930	5.2±0.25	8.75±0.25	5.6±0.25

低阻分流器贴片电阻规格书-RZ 系列

Specification Low-Resistance Shunt Chip Resistors-Type *RZ series*

10.2 建议回流焊曲线 (Recommend reflow soldering profile)

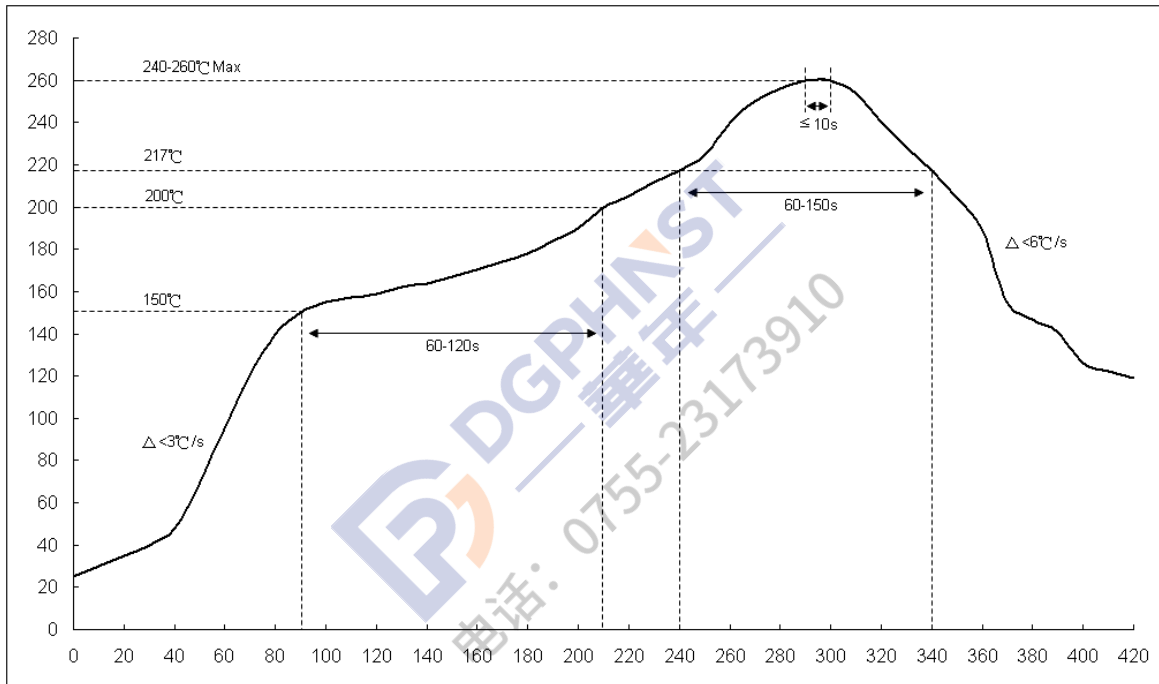

10.3 建议波峰焊曲线 (Recommend wave soldering profile)

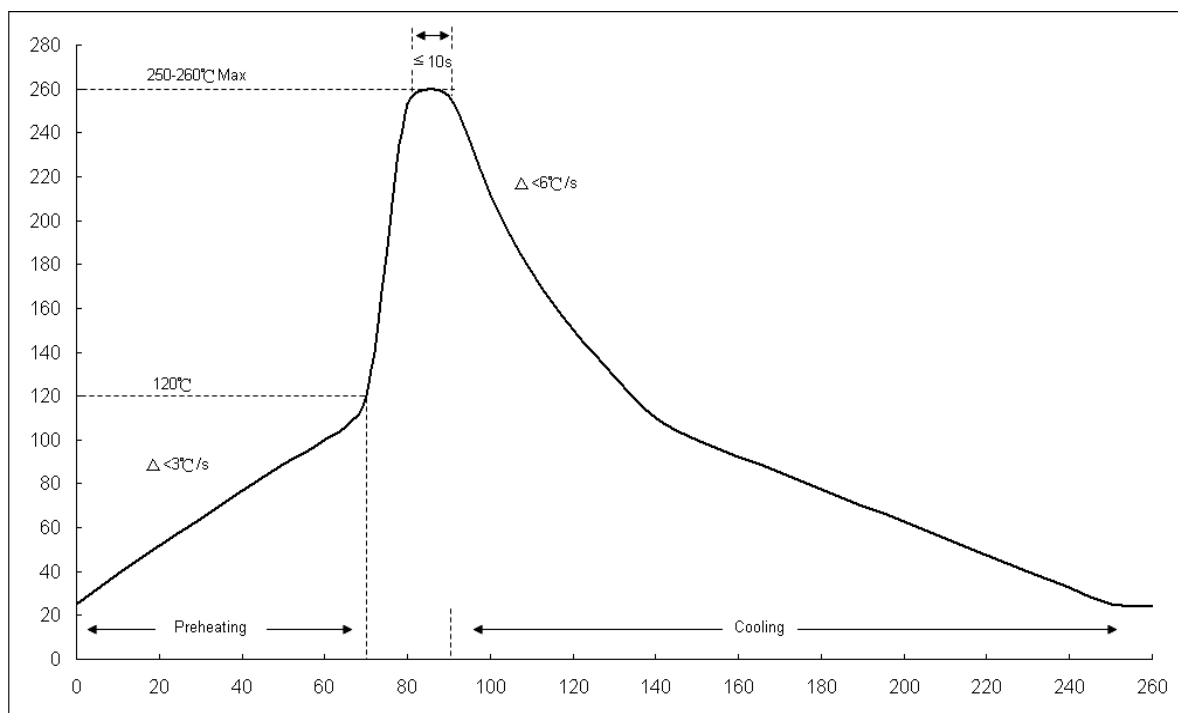

低阻分流器贴片电阻规格书-RZ 系列

Specification Low-Resistance Shunt Chip Resistors-Type *RZ series*

10.4 手工焊温度 (hand soldering temperature)

烙铁温度 $350\pm 10^{\circ}\text{C}$ ，3 秒之内，避免烙铁接触电阻本体

The iron temperature is $350\pm 10^{\circ}\text{C}$, hand soldering time less than 3S. Avoid solder iron tip direct touch the components body

★所有产品规格改变不再另行通知

★All product specification and data are subject to change without notice.

DGPHYST
— 華年 —
电话: 0755-23173912