

## Socay High Surge Micro Varistor

### SV1206H471G0A

#### Features

- ◆ RoHS Compliant.
- ◆ SMD Type Body Size 1206.
- ◆ Meet IEC61000-4-5 Standard.
- ◆ Bidirectional and Symmetrical V/I Characteristics.
- ◆ Large Withstanding Surge Current Capability: 40A (@8/20μs).
- ◆ Operating Temperature Range: -55°C ~ +125°C.
- ◆ Multi-Layers Construction Provides Higher Power Dissipation.

Top View (1206)

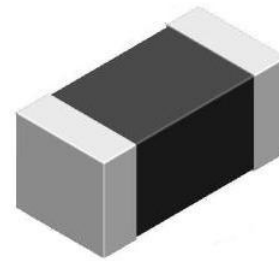

#### Electrical Characteristics (25±5°C)

Symbol	Minimum	Typical	Maximum	Units
$V_{RMS}$	—	—	300	V
$V_{DC}$	—	—	385	V
$V_V$	423	—	517	V
$V_C$	—	—	775	V
$I_{max}$	—	—	40	A
$W_{max}$	—	—	0.4	J

#### Notes:

1. The breakdown voltage was measured at 1mA.
2. The clamping voltage was measured at 8\*20μs standard current, 1206(5A).
3. The surge current was tested at 8/20μs waveform.
4. The capacitance value only for customer reference, it's not formal specification.
5. The components shall be employed within 1 year, in the nitrogen condition.

# Socay High Surge Micro Varistor

## SV1206H471G0A

### Size (Unit: mm)

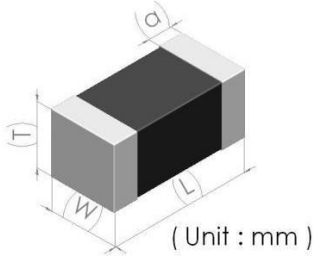

<b>Model</b>	1206
<b>Length(L)</b>	3.20+0.60/-0.20
<b>Width(W)</b>	1.60+0.40/-0.20
<b>Thickness(T)</b>	1.90 Max
<b>Termination(a)</b>	0.50±0.20

### Recommended Solder Pad Layout (Unit : mm)

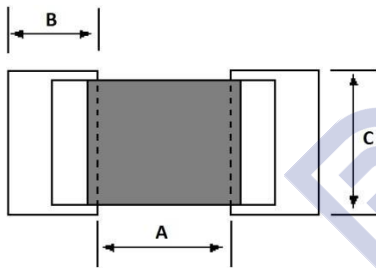

<b>Size</b>	1206
<b>A</b>	1.8~2.5
<b>B</b>	1.2~1.8
<b>C</b>	1.5~2.0

### The I<sub>R</sub> Reflow and Temperature of Soldering for Pb Free

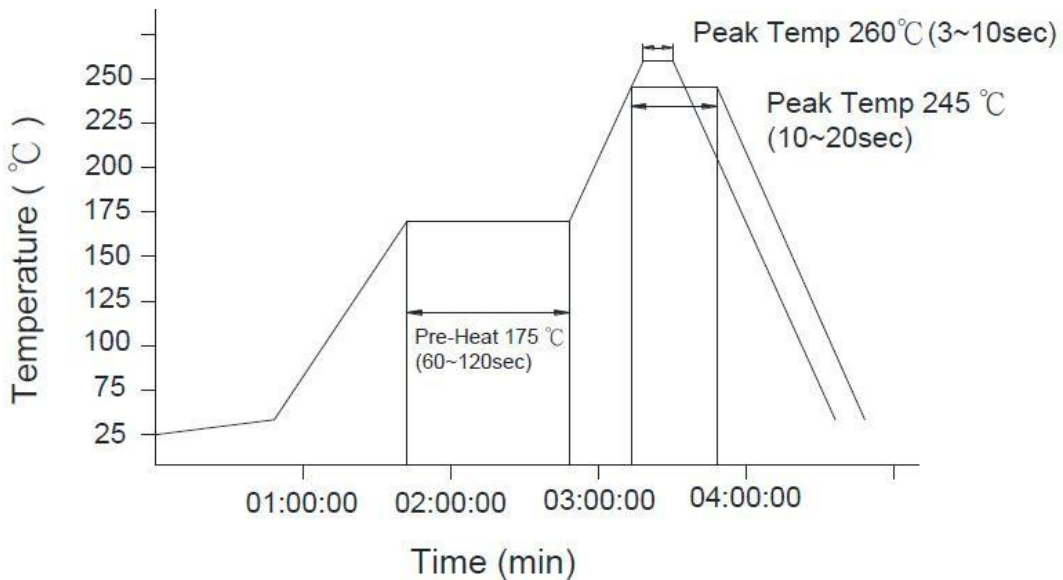

# Socay High Surge Micro Varistor

## SV1206H471G0A

### The IR Reflow and Temperature of Soldering for Pb Free (Continue)

#### IR reflow Pb free process suggestion profile:

- (1) The solder recommend is Sn96.5/Ag 3.5.
- (2) Ramp-up rate (217°C to peak) +3°C/second max.
- (3) Temp. maintain at 175±25°C 180 seconds max.
- (4) Temp. maintain above 217°C 60~150 seconds.
- (5) Peak temperature range 245°C+20°C/-10°C within 5°C of actually peak temperature (t<sub>p</sub>)10~20 seconds.
- (6) Ramp down rate -6°C/second max.

Perform adequate test in advance as the reflow temperature profile will vary according to the conditions of the manufacturing process, and the specification of the reflow furnace.

### Hand Soldering

#### Resistance to soldering heat-high temperature resistance: 260°C, 10 secs and 3 times.

In hand soldering of the SV1206H471G0A Device. Large temperature gradient between preheated the SV1206H471G0A Device and the tip of soldering iron may cause electrical failures and mechanical damages such as crackings or breaking of the devices. The soldering shall be carefully controlled and carried out so that the temperature gradient is kept minimum with following recommended conditions for hand soldering.

#### Recommended Soldering Condition 1

- ◆ **Solder:** 0.12~0.18mm Thread solder (Sn96.5:Ag3.5) with soldering flux in the core. Rosin-based and non-activated flux is recommended.
- ◆ **Preheating:** The SV1206H471G0A Device shall be preheated so that Temperature Gradient between the devices and the tip of soldering iron is 150°C or below.
- ◆ **Soldering Iron:** Rated Power of 20w max with 3mm soldering tip in diameter. Temperature of soldering iron tip 380°C max, 3-5sec (The required amount of solder shall be melted in advance on the soldering tip.)
- ◆ **Cooling:** After soldering. The SV1206H471G0A Device shall be cooled gradually at room ambient temperature.

#### Recommended Soldering Condition 2 (Without preheating)

- ◆ Solder iron tip shall not directly touch to ceramic dielectrics.
- ◆ Solder iron tip shall be fully preheated before soldering while soldering iron tip to the external electrode of SV1206H471G0A Device.

### Packaging Specification (Unit: mm)

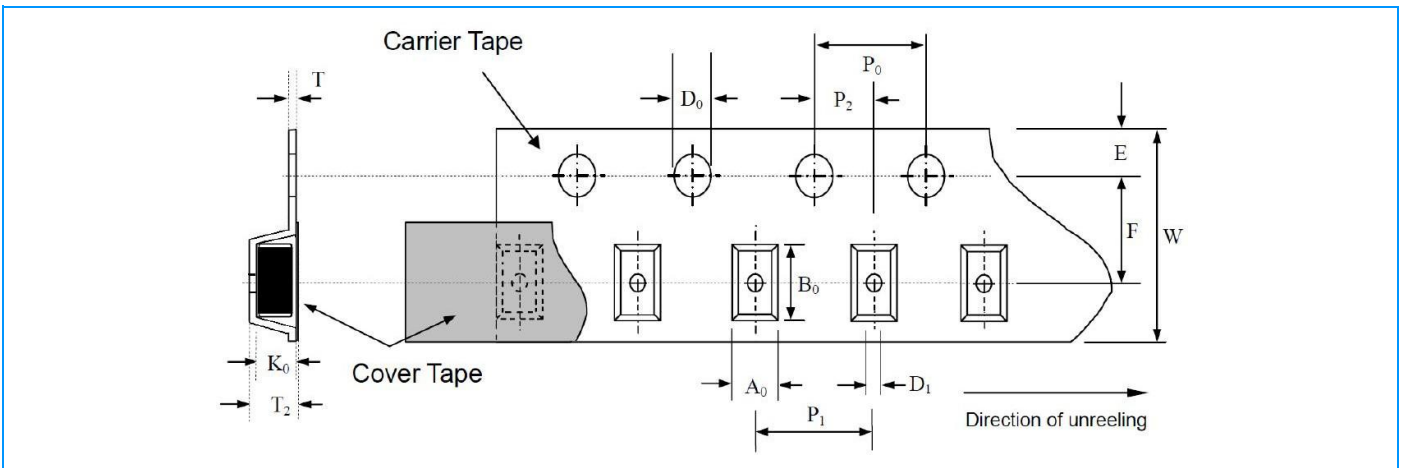

Symbol	A <sub>0</sub> ±0.10	B <sub>0</sub> ±0.10	K <sub>0</sub> ±0.10	T ±0.05	T <sub>2</sub> ±0.05	D <sub>0</sub> +0.10 -0.00	D <sub>1</sub> ±0.05	P <sub>1</sub> ±0.10	P <sub>2</sub> ±0.05	P <sub>0</sub> ±0.05	W ±0.20	E ±0.10	F ±0.05
1206	2.10	3.90	2.00	0.22	2.22	1.50	1.00	4.00	2.00	4.00	8.00	1.75	3.50

**Socay High Surge Micro Varistor**
**SV1206H471G0A**
**Standard Packaging**

Device	Quantity	Reel Size
SV1206H471G0A	2000 pcs	178.0mm

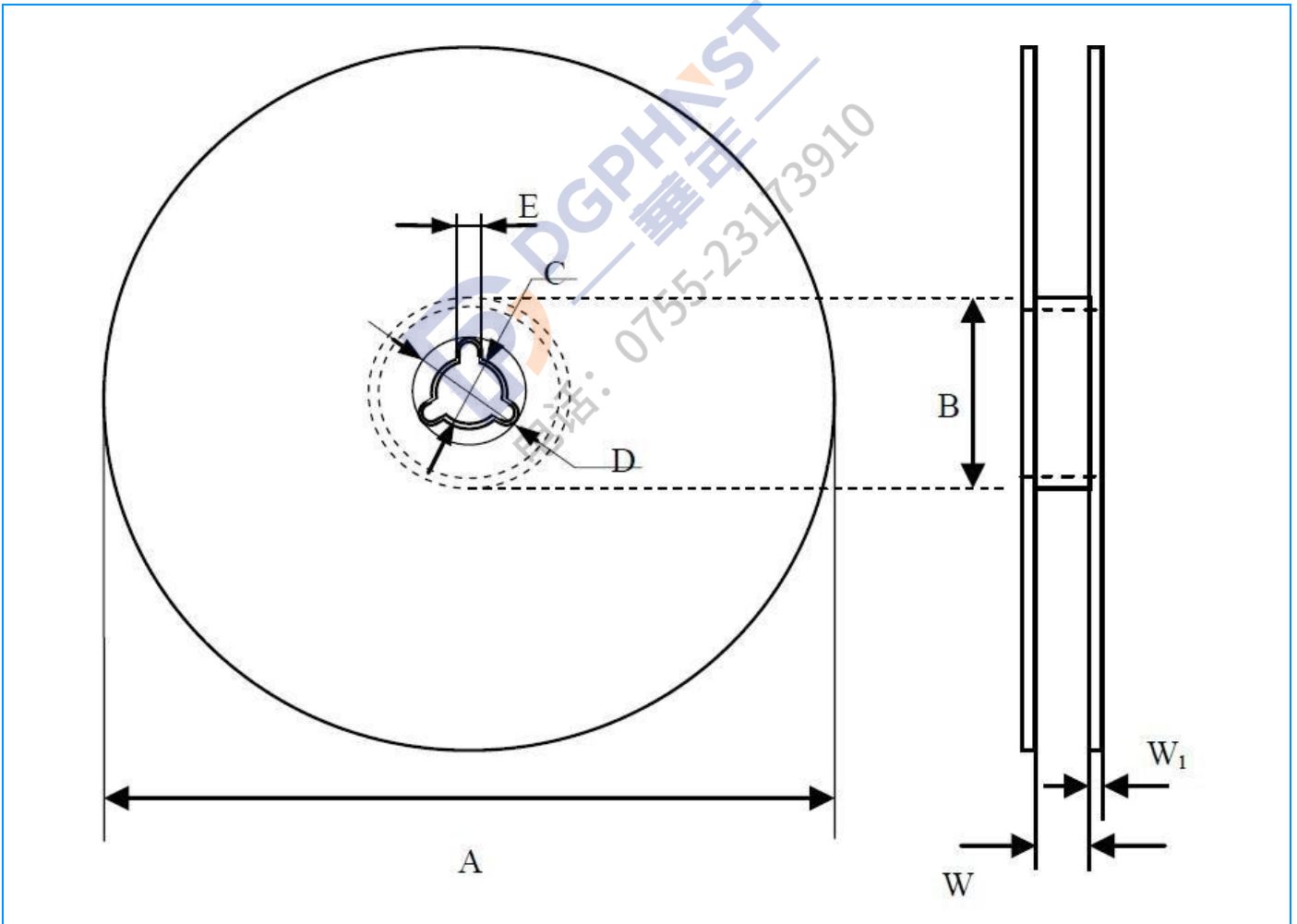
**Reel Dimension (Unit: mm)**

Symbol	A	B	C	D	E	W	W <sub>1</sub>
<b>1206</b>	178.0±1.0	60.0±0.5	13.0±0.2	21.0±0.2	2.0±0.5	9.0±0.5	1.5±0.1

**Socay High Surge Micro Varistor**
**SV1206H471G0A**
**Environmental Reliability Testing**

Item	Requirement	Test Condition
<b>High Temperature Storage</b>	<ul style="list-style-type: none"> <li>◆ Breakdown voltage change: within <math>\pm 10\%</math>.</li> <li>◆ No mechanical damage.</li> </ul>	<ul style="list-style-type: none"> <li>◆ Temperature: <math>125 \pm 2^\circ\text{C}</math>.</li> <li>◆ Time: <math>1000 \pm 2</math> hours.</li> <li>◆ Test after placing in ambient temperature for 24 hours.</li> </ul>
<b>Low Temperature Storage</b>	<ul style="list-style-type: none"> <li>◆ Breakdown voltage change: within <math>\pm 10\%</math>.</li> <li>◆ No mechanical damage.</li> </ul>	<ul style="list-style-type: none"> <li>◆ Temperature: <math>-40 \pm 2^\circ\text{C}</math>.</li> <li>◆ Time: <math>1000 \pm 2</math> hours.</li> <li>◆ Test after placing in ambient temperature for 24 hours.</li> </ul>
<b>Temperature Cycle</b>	<ul style="list-style-type: none"> <li>◆ Breakdown voltage change: within <math>\pm 10\%</math>.</li> <li>◆ No mechanical damage.</li> </ul>	<ul style="list-style-type: none"> <li>◆ Step 1: <math>-40 \pm 3^\circ\text{C}</math>; time: <math>30 \pm 3\text{min}</math>.</li> <li>◆ Step 2: <math>25^\circ\text{C}</math>; time: 1 hour.</li> <li>◆ Step 3: <math>125 \pm 3^\circ\text{C}</math>; time: <math>30 \pm 3\text{min}</math>.</li> <li>◆ Step 4: <math>25^\circ\text{C}</math>; time: 1 hour.</li> <li>◆ Number of cycle: 5 times.</li> <li>◆ Test after placing in ambient temperature for 24 hours.</li> </ul>
<b>High Temperature Load</b>	<ul style="list-style-type: none"> <li>◆ Breakdown voltage change: within <math>\pm 10\%</math>.</li> <li>◆ No mechanical damage.</li> </ul>	<ul style="list-style-type: none"> <li>◆ Temperature: <math>85 \pm 2^\circ\text{C}</math>.</li> <li>◆ Rated working voltage applied.</li> <li>◆ Time: <math>1000 \pm 2</math> hours.</li> <li>◆ Test after placing in ambient temperature for 24 hours.</li> </ul>
<b>Damp Heat Load/ Humidity Load</b>	<ul style="list-style-type: none"> <li>◆ Breakdown voltage change: within <math>\pm 10\%</math>.</li> <li>◆ No mechanical damage.</li> </ul>	<ul style="list-style-type: none"> <li>◆ Temperature: <math>40 \pm 2^\circ\text{C}</math>.</li> <li>◆ Humidity: 90-95% RH.</li> <li>◆ Rated working voltage applied.</li> <li>◆ Time: <math>500 \pm 2</math> hours.</li> <li>◆ Test after placing in ambient temperature for 24 hours.</li> </ul>