



SOD-523 Plastic-Encapsulate Diodes

BZX584C2V4-BZX584C43 ZENER DIODE

FEATURES

- Planar Die Construction
- 150mW Power Dissipation
- Zener Voltages from 2.4 – 43V

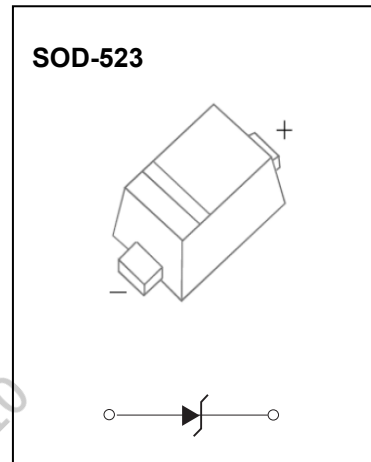

MAXIMUM RATINGS($T_a=25^\circ\text{C}$ unless otherwise specified)

| Characteristic | Symbol | Value | Unit |
|--|-----------------|----------|------|
| Forward Voltage @ $I_F=10\text{mA}$ | V_F | 0.9 | V |
| Power Dissipation | P_D | 150 | mW |
| Thermal Resistance from Junction to Ambient | $R_{\theta JA}$ | 833 | /W |
| Operation Junction and Storage Temperature Range | T_J, T_{stg} | -55~+150 | |

ELECTRICAL CHARACTERISTICS

T_a=25°C unless otherwise specified

| Type Number | Type Code | Zener Voltage Range (Note 2) | | | | Maximum Zener Impedance (Note 3) | | | Maximum Reverse Current | | Typical temperature coefficient @ I _{ZT} mV/°C | |
|-------------|-----------|---------------------------------|--------|--------|-----------------|----------------------------------|----------------------------------|------|-------------------------|----------------|---|------|
| | | V _Z @I _{ZT} | | | I _{ZT} | Z _{ZT} @I _{ZT} | Z _{ZK} @I _{ZK} | | I _R | V _R | Min | Max |
| | | Nom(V) | Min(V) | Max(V) | (mA) | (Ω) | (mA) | (μA) | (V) | | | |
| BZX584C2V4 | Z11 | 2.4 | 2.20 | 2.60 | 5 | 100 | 600 | 1.0 | 50 | 1.0 | -3.5 | 0 |
| BZX584C2V7 | Z12 | 2.7 | 2.5 | 2.9 | 5 | 100 | 600 | 1.0 | 20 | 1.0 | -3.5 | 0 |
| BZX584C3V0 | Z13 | 3.0 | 2.8 | 3.2 | 5 | 95 | 600 | 1.0 | 10 | 1.0 | -3.5 | 0 |
| BZX584C3V3 | Z14 | 3.3 | 3.1 | 3.5 | 5 | 95 | 600 | 1.0 | 5 | 1.0 | -3.5 | 0 |
| BZX584C3V6 | Z15 | 3.6 | 3.4 | 3.8 | 5 | 90 | 600 | 1.0 | 5 | 1.0 | -3.5 | 0 |
| BZX584C3V9 | Z16 | 3.9 | 3.7 | 4.1 | 5 | 90 | 600 | 1.0 | 3 | 1.0 | -3.5 | 0 |
| BZX584C4V3 | Z17 | 4.3 | 4.0 | 4.6 | 5 | 90 | 600 | 1.0 | 3 | 1.0 | -3.5 | 0 |
| BZX584C4V7 | Z1 | 4.7 | 4.4 | 5.0 | 5 | 80 | 500 | 1.0 | 3 | 2.0 | -3.5 | 0.2 |
| BZX584C5V1 | Z2 | 5.1 | 4.8 | 5.4 | 5 | 60 | 480 | 1.0 | 2 | 2.0 | -2.7 | 1.2 |
| BZX584C5V6 | Z3 | 5.6 | 5.2 | 6.0 | 5 | 40 | 400 | 1.0 | 1 | 2.0 | -2.0 | 2.5 |
| BZX584C6V2 | Z4 | 6.2 | 5.8 | 6.6 | 5 | 10 | 150 | 1.0 | 3 | 4.0 | 0.4 | 3.7 |
| BZX584C6V8 | Z5 | 6.8 | 6.4 | 7.2 | 5 | 15 | 80 | 1.0 | 2 | 4.0 | 1.2 | 4.5 |
| BZX584C7V5 | Z6 | 7.5 | 7.0 | 7.9 | 5 | 15 | 80 | 1.0 | 1 | 5.0 | 2.5 | 5.3 |
| BZX584C8V2 | Z7 | 8.2 | 7.7 | 8.7 | 5 | 15 | 80 | 1.0 | 0.7 | 5.0 | 3.2 | 6.2 |
| BZX584C9V1 | Z8 | 9.1 | 8.5 | 9.6 | 5 | 15 | 100 | 1.0 | 0.5 | 6.0 | 3.8 | 7.0 |
| BZX584C10 | Z9 | 10 | 9.4 | 10.6 | 5 | 20 | 150 | 1.0 | 0.2 | 7.0 | 4.5 | 8.0 |
| BZX584C11 | Y1 | 11 | 10.4 | 11.6 | 5 | 20 | 150 | 1.0 | 0.1 | 8.0 | 5.4 | 9.0 |
| BZX584C12 | Y2 | 12 | 11.4 | 12.7 | 5 | 25 | 150 | 1.0 | 0.1 | 8.0 | 6.0 | 10.0 |
| BZX584C13 | Y3 | 13 | 12.4 | 14.1 | 5 | 30 | 170 | 1.0 | 0.1 | 8.0 | 7.0 | 11.0 |
| BZX584C15 | Y4 | 15 | 13.8 | 15.6 | 5 | 30 | 200 | 1.0 | 0.1 | 10.5 | 9.2 | 13.0 |
| BZX584C16 | Y5 | 16 | 15.3 | 17.1 | 5 | 40 | 200 | 1.0 | 0.1 | 11.2 | 10.4 | 14.0 |
| BZX584C18 | Y6 | 18 | 16.8 | 19.1 | 5 | 45 | 225 | 1.0 | 0.1 | 12.6 | 12.4 | 16.0 |
| BZX584C20 | Y7 | 20 | 18.8 | 21.2 | 5 | 55 | 225 | 1.0 | 0.1 | 14.0 | 14.4 | 18.0 |
| BZX584C22 | Y8 | 22 | 20.8 | 23.3 | 5 | 55 | 250 | 1.0 | 0.1 | 15.4 | 16.4 | 20.0 |
| BZX584C24 | Y9 | 24 | 22.8 | 25.6 | 5 | 70 | 250 | 1.0 | 0.1 | 16.8 | 18.4 | 22.0 |
| BZX584C27 | Y10 | 27 | 25.1 | 28.9 | 2 | 80 | 300 | 0.5 | 0.1 | 18.9 | 21.4 | 25.3 |
| BZX584C30 | Y11 | 30 | 28.0 | 32.0 | 2 | 80 | 300 | 0.5 | 0.1 | 21.0 | 24.4 | 29.4 |
| BZX584C33 | Y12 | 33 | 31.0 | 35.0 | 2 | 80 | 325 | 0.5 | 0.1 | 23.1 | 27.4 | 33.4 |
| BZX584C36 | Y13 | 36 | 34.0 | 38.0 | 2 | 90 | 350 | 0.5 | 0.1 | 25.2 | 30.4 | 37.4 |
| BZX584C39 | Y14 | 39 | 37.0 | 41.0 | 2 | 130 | 350 | 0.5 | 0.1 | 27.3 | 33.4 | 41.2 |
| BZX584C43 | Y15 | 43 | 40.0 | 46.0 | 2 | 100 | 700 | 1 | 0.1 | 32 | 10 | 12 |

- Notes: 1. Valid provided that device terminals are kept at ambient temperature.
 2. Tested with pulses, period=5ms,pulse width =300μs.
 3. f = 1 kHz.

Typical Characteristics

Zener Characteristics (V_z Up to 10 V)

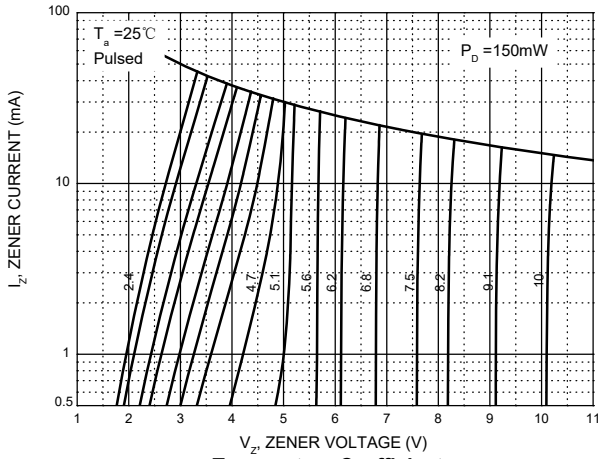

Zener Characteristics (11 V to 43 V)

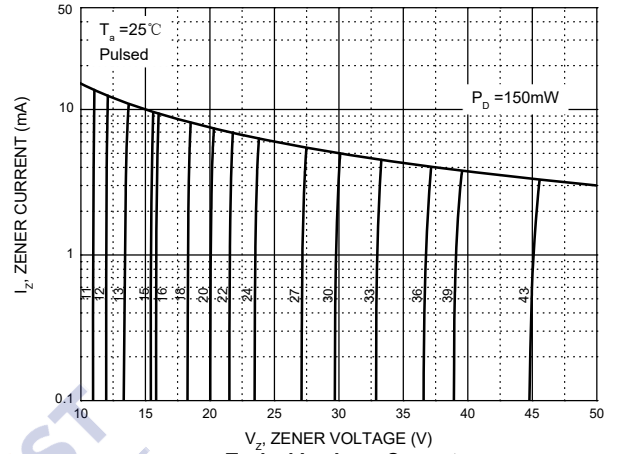

Temperature Coefficients

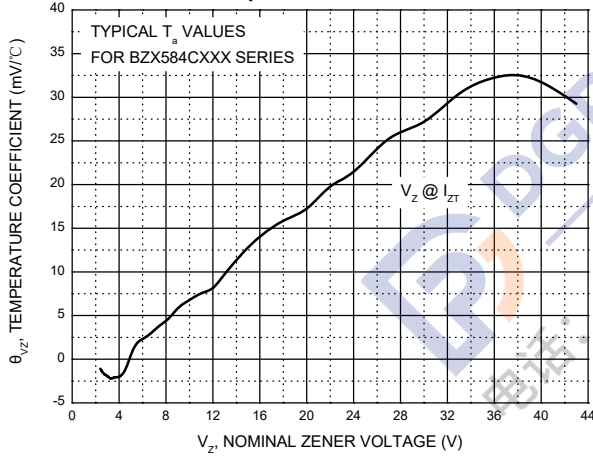

Typical Leakage Current

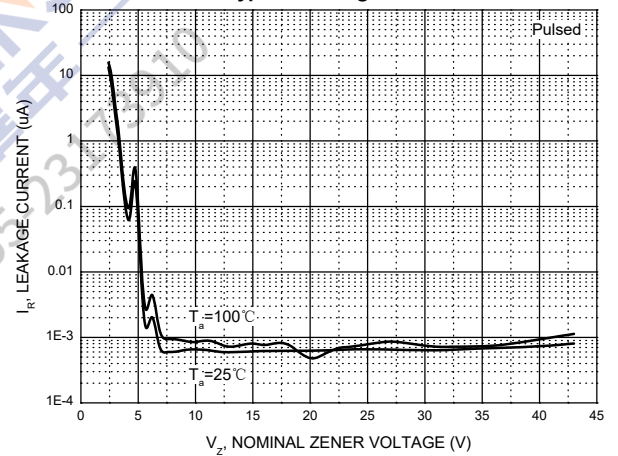

Typical Capacitance

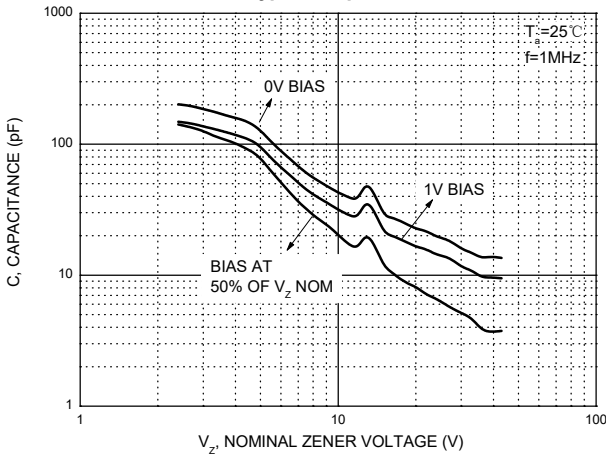

Effect of Zener Voltage on Zener Impedance

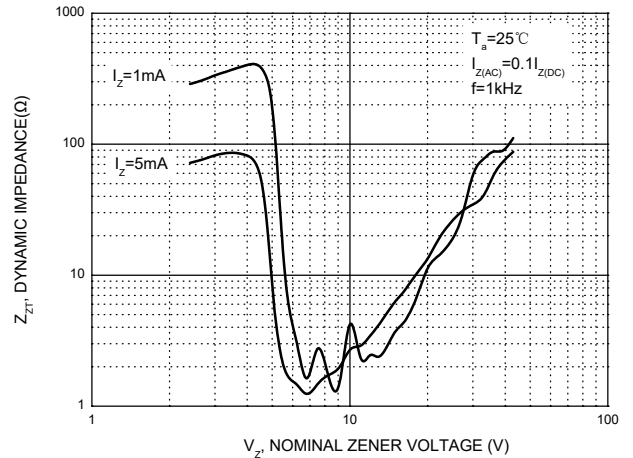

Power Derating Curve

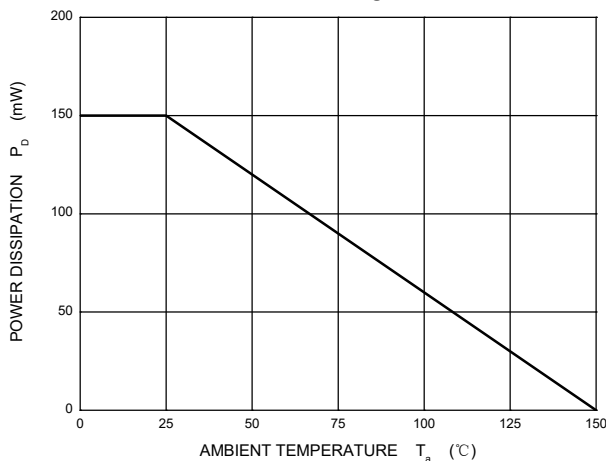

SOD-523 Package Outline Dimensions

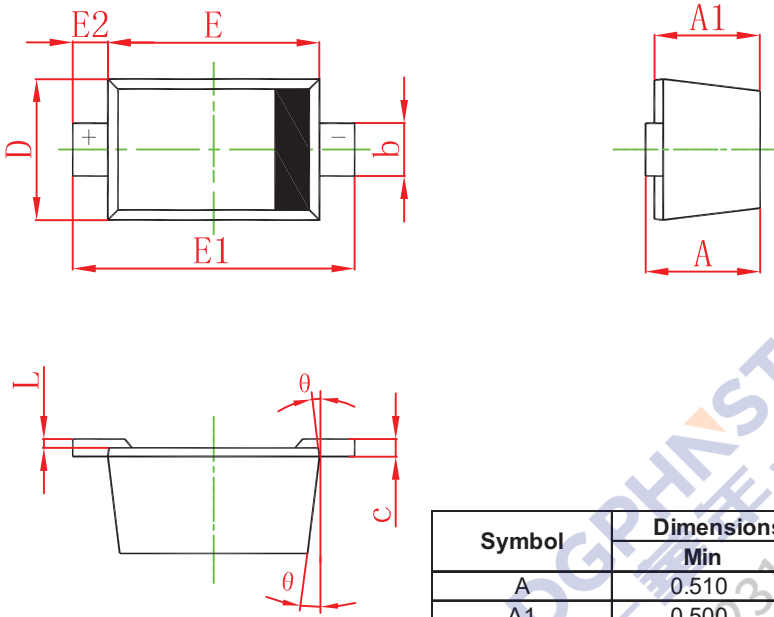

| Symbol | Dimensions In Millimeters | | Dimensions In Inches | |
|--------|---------------------------|-------|----------------------|-------|
| | Min | Max | Min | Max |
| A | 0.510 | 0.770 | 0.020 | 0.031 |
| A1 | 0.500 | 0.700 | 0.020 | 0.028 |
| b | 0.250 | 0.350 | 0.010 | 0.014 |
| c | 0.080 | 0.150 | 0.003 | 0.006 |
| D | 0.750 | 0.850 | 0.030 | 0.033 |
| E | 1.100 | 1.300 | 0.043 | 0.051 |
| E1 | 1.500 | 1.700 | 0.059 | 0.067 |
| E2 | 0.200 REF | | 0.008 REF | |
| L | 0.010 | 0.070 | 0.001 | 0.003 |
| θ | 7° REF | | 7° REF | |

SOD-523 Suggested Pad Layout

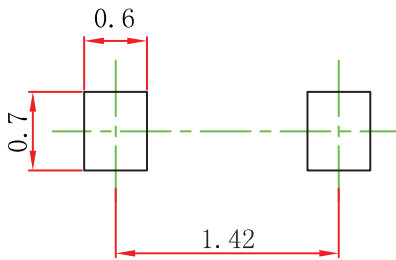

Note:

1. Controlling dimension: in millimeters.
2. General tolerance: $\pm 0.05\text{mm}$.
3. The pad layout is for reference purposes only.

NOTICE

JSCJ reserves the right to make modifications, enhancements, improvements, corrections or other changes without further notice to any product herein. JSCJ does not assume any liability arising out of the application or use of any product described herein.

SOD-523 Tape and Reel

SOD-523 Embossed Carrier Tape

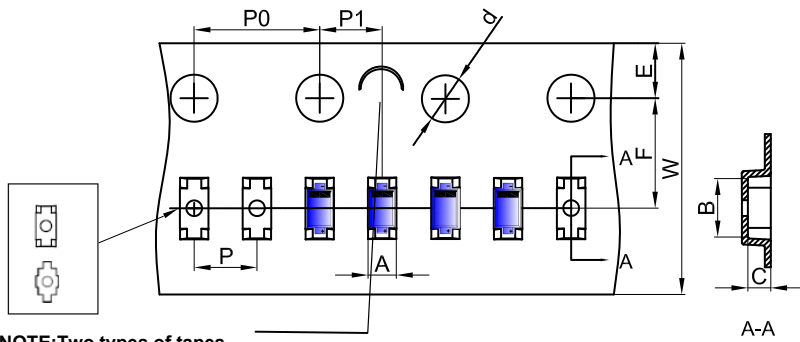

Packaging Description:

SOD-523 parts are shipped in tape. The carrier tape is made from a dissipative (carbon filled) polycarbonate resin. The cover tape is a multilayer film (Heat Activated Adhesive in nature) primarily composed of polyester film, adhesive layer, sealant, and anti-static sprayed agent. These reeled parts in standard option are shipped with 8,000 units per 7" or 17.8cm diameter reel. The reels are clear in color and is made of polystyrene plastic (anti-static coated).

NOTE: Two types of tapes coexist side by side.

NOTE: TO CAVE 'C' ON CARRIER TAPE PER 120MM

| Dimensions are in millimeter | | | | | | | | | | |
|------------------------------|-----|------|------|-------|------|------|------|------|------|------|
| Pkg type | A | B | C | d | E | F | P0 | P | P1 | W |
| SOD-523 | 0.9 | 1.94 | 0.73 | Ø1.50 | 1.75 | 3.50 | 4.00 | 2.00 | 2.00 | 8.00 |

SOD-523 Tape Leader and Trailer

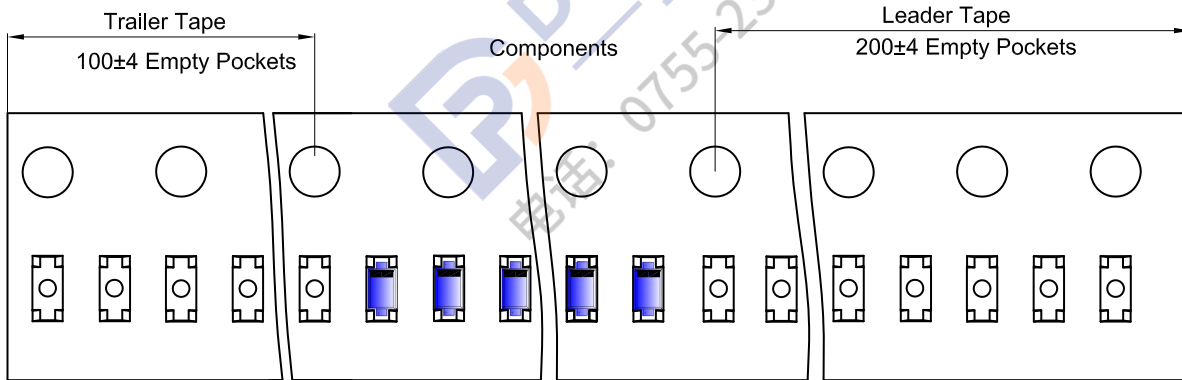

SOD-523 Reel

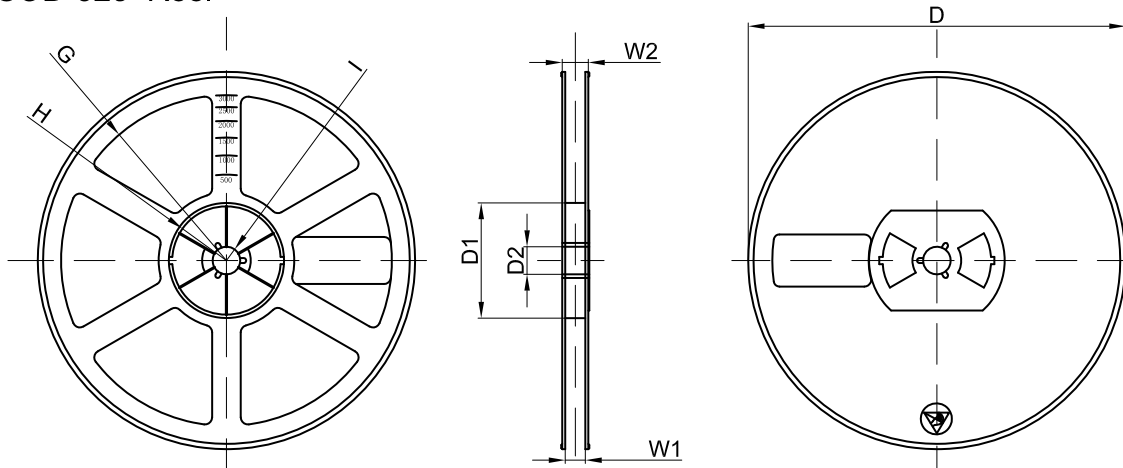

| Dimensions are in millimeter | | | | | | | | |
|------------------------------|---------|-------|-------|--------|--------|-------|------|-------|
| Reel Option | D | D1 | D2 | G | H | I | W1 | W2 |
| 7" Dia | Ø178.00 | 54.40 | 13.00 | R78.00 | R25.60 | R6.50 | 9.50 | 12.30 |

| REEL | Reel Size | Box | Box Size(mm) | Carton | Carton Size(mm) | G.W.(kg) |
|----------|-----------|-------------|--------------|-------------|-----------------|----------|
| 8000 pcs | 7 inch | 120,000 pcs | 203×203×195 | 480,000 pcs | 438×438×220 | |