

LEGM15BE120E1HZ

IGBT Power Module

Features:

- $V_{CE}=1200V$ $I_C=15A$
- Low $V_{CE(sat)}$
- V_{CEsat} with positive temperature coefficient
- Maximum junction temperature 150°C
- Isolation Type Package

Applications:

- The inverter
- Motor control and drives

Package Type & Internal Circuit

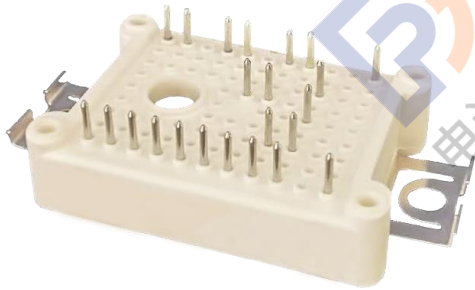

E1

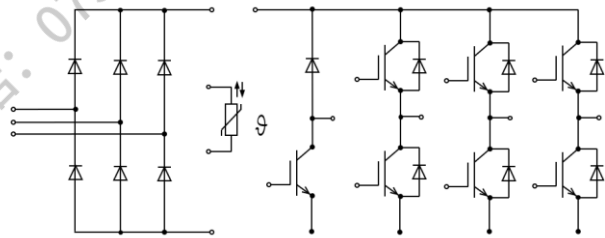

Internal Circuit

Maximum Rated Values (IGBT Inverter)

Symbol	Parameter	Conditions	Ratings	Unit
V_{CES}	Collector-emitter voltage	$V_{EC}=0V, I_C=1mA, T_{vj}=25^\circ C$	1200	V
I_C	Continuous Collector Current	$T_C=100^\circ C$	15	A
I_{CRM}	Peak Collector Current	$I_{CRM}=2I_C$	30	A
V_{GES}	Gate-Emitter Voltage	$T_{vj}=25^\circ C$	± 30	V
P_{tot}	Total Power Dissipation	$T_C=25^\circ C, T_{vjmax}=150^\circ C$	130	W

Characteristics Values (IGBT Inverter)

Symbol	Parameter	Conditions	Min.	Typ.	Max.	Unit	
$V_{CE(sat)}$	Collector-Emitter Saturation Voltage	$I_C=15\text{ A}, V_{GE}=15\text{ V}, T_{vj}=25\text{ }^\circ\text{C}$		1.85	2.5	V	
		$I_C=15\text{ A}, V_{GE}=15\text{ V}, T_{vj}=125\text{ }^\circ\text{C}$		2.0	2.7	V	
$V_{GE(th)}$	Gate Threshold Voltage	$I_C=5.0\text{ mA}, V_{CE}=V_{GE}, T_{vj}=25\text{ }^\circ\text{C}$	5	5.6	7	V	
I_{CES}	Collector-Emitter Cut-off Current	$V_{CE}=1200\text{ V}, V_{GE}=0\text{ V}, T_{vj}=25\text{ }^\circ\text{C}$			1.0	mA	
I_{GES}	Gate-Emitter Leakage Current	$V_{CE}=0\text{ V}, V_{GE}=15\text{ V}, T_{vj}=25\text{ }^\circ\text{C}$			410	nA	
C_{ies}	Input capacitance	$f=1\text{ MHz}, T_{vj}=25\text{ }^\circ\text{C}, V_{CE}=25\text{ V}, V_{GE}=0\text{ V}$		1.29		nF	
C_{res}	Reverse transfer capacitance				41	pF	
$t_{d(on)}$	Turn-on Delay Time, Inductive Load	$I_C=15\text{ A}, V_{CE}=600\text{ V}$ $V_{GE}=\pm 15\text{ V}$ $R_G=35\Omega$ $T_{vj}=25\text{ }^\circ\text{C}$		94		ns	
t_r	Rise Time, Inductive Load				52	ns	
$t_{d(off)}$	Turn-off Delay Time, Inductive Load				243	ns	
t_f	Fall Time, Inductive Load				190	ns	
E_{on}	Turn-on Energy Loss per Pulse				1.95	mJ	
E_{off}	Turn-off Energy Loss per Pulse				0.81	mJ	
$t_{d(on)}$	Turn-on Delay Time, Inductive Load		$I_C=15\text{ A}, V_{CE}=600\text{ V}$ $V_{GE}=\pm 15\text{ V}$ $R_G=35\Omega$ $T_{vj}=125\text{ }^\circ\text{C}$		85		ns
t_r	Rise Time, Inductive Load					114	ns
$t_{d(off)}$	Turn-off Delay Time, Inductive Load					202	ns
t_f	Fall Time, Inductive Load					312	ns
E_{on}	Turn-on Energy Loss per Pulse				2.1	mJ	
E_{off}	Turn-off Energy Loss per Pulse				1.2	mJ	
R_{thJC}	Thermal resistance, junction to case	per IGBT			1.15	K/W	
$T_{vj\text{ op}}$	Temperature under switching conditions		-40		125	$^\circ\text{C}$	
I_{sc}	SC	$V_{GE}\leq 15\text{ V}, V_{CE}=600\text{ V},$ $t_p\leq 10\mu\text{s}, T_{vj}=125\text{ }^\circ\text{C},$ $V_{CEmax}=V_{CES}-L_{sCE}\cdot di/dt$		60		A	

Maximum Rated Values (Diode Inverter)

Symbol	Parameter	Conditions	Min.	Typ.	Max.	Unit
V_{RRM}	Repetitive Peak Reverse Voltage	$T_{vj}=25\text{ }^{\circ}\text{C}$		1200		V
I_F	Continuous DC Forward Current	$T_C=100\text{ }^{\circ}\text{C}$		15		A
I_{FRM}	Repetitive Peak Forward Current	$t_p=1\text{ ms}$		30		A
I^2t	I^2t Value	$V_R=0\text{ V}$, $t_p=10\text{ ms}$, $T_{vj}=150\text{ }^{\circ}\text{C}$		15		A^2s

Characteristic Values (Diode Inverter)

Symbol	Parameter	Conditions	Min.	Typ.	Max.	Unit
V_F	Forward Voltage	$I_F=15\text{ A}$, $V_{CE}=0\text{ V}$, $T_{vj}=25\text{ }^{\circ}\text{C}$		1.9	2.5	V
		$I_F=15\text{ A}$, $V_{CE}=0\text{ V}$, $T_{vj}=125\text{ }^{\circ}\text{C}$		1.90		V
t_{rr}	Reverse Recovery time	$I_F=15\text{ A}$, $V_R=600\text{ V}$		220		ns
Q_r	Recovered Charge	$-di/dt=300\text{ A/us}$ $T_{vj}=25\text{ }^{\circ}\text{C}$		0.8		μC
E_{rec}	Reverse Recovery Energy	$V_{GE}=-15\text{ V}$		0.2		mJ
t_{rr}	Reverse Recovery time	$I_F=15\text{ A}$, $V_R=600\text{ V}$		370		ns
Q_r	Recovered Charge	$-di/dt=300\text{ A/us}$ $T_{vj}=125\text{ }^{\circ}\text{C}$		1.4		μC
E_{rec}	Reverse Recovery Energy	$V_{GE}=-15\text{ V}$		0.4		mJ
R_{thJC}	Thermal resistance, junction to case				1.75	K/W
$T_{vj\text{ op}}$	Temperature under switching conditions		-40		125	$^{\circ}\text{C}$

Maximum Rated Values (Diode Rectifier)

Symbol	Parameter	Conditions	Min.	Typ.	Max.	Unit
V_{RRM}	Repetitive peak reverse voltage	$T_{vj}=25\text{ }^{\circ}\text{C}$		1800		V
I_{FRMSM}	Maximum RMS forward current per chip	$T_c=80\text{ }^{\circ}\text{C}$		30		A
I_{RMSM}	Maximum RMS current at rectifier chip	$T_c=80\text{ }^{\circ}\text{C}$		30		A
I_{FSM}	Surge forward current	$t_p=10\text{ms}$ $T_{vj}=25\text{ }^{\circ}\text{C}$		190		A
I^2t	I^2t -value			180		A ² S
I_{FSM}	Surge forward current	$t_p=10\text{ms}$ $T_{vj}=125\text{ }^{\circ}\text{C}$		160		A
I^2t	I^2t -value			130		A ² S

Characteristic Values (Diode Rectifier)

V_F	Forward voltage	$T_{vj}=125\text{ }^{\circ}\text{C}$ $I_F=15\text{A}$		0.98		V
I_R	Reverse current	$T_{vj}=125\text{ }^{\circ}\text{C}$ $V_R=1800\text{V}$		1.1		mA
R_{thjc}	Thermal resistance junction to case	per diode			1.18	K/W
T_{vjop}	Temperature under switching conditions		-40		125	$^{\circ}\text{C}$

Maximum Rated Values (IGBT Brake-Chopper)

Symbol	Parameter	Conditions	Min.	Typ.	Max.	Unit
V_{CES}	Collector-emitter voltage	$T_{vj}=25^{\circ}\text{C}$		1200		V
I_C	Continuous Collector Current	$T_C = 100^{\circ}\text{C}, T_{vj\max} = 150^{\circ}\text{C}$		15		A
I_{CRM}	Peak Collector Current	$I_{CRM}=2I_C$		30		A
V_{GES}	Gate-Emitter Voltage	$T_{vj}=25^{\circ}\text{C}$	-20		20	V

Characteristic Values (IGBT Brake-Chopper)

Symbol	Parameter	Conditions	Min.	Typ.	Max.	Unit	
$V_{CE(sat)}$	Collector-Emitter Saturation Voltage	$I_C=15\text{ A}, V_{GE}=15\text{ V}, T_{vj}=25^{\circ}\text{C}$		1.85	2.5	V	
		$I_C=15\text{ A}, V_{GE}=15\text{ V}, T_{vj}=125^{\circ}\text{C}$		2.0	2.7	V	
$V_{GE(th)}$	Gate Threshold Voltage	$I_C=5.0\text{ mA}, V_{CE}=V_{GE}, T_{vj}=25^{\circ}\text{C}$	5	5.6	7	V	
I_{CES}	Collector-Emitter Cut-off Current	$V_{CE}=1200\text{ V}, V_{GE}=0\text{ V}, T_{vj}=25^{\circ}\text{C}$			1.0	mA	
I_{GES}	Gate-Emitter Leakage Current	$V_{CE}=0\text{ V}, V_{GE}=15\text{ V}, T_{vj}=25^{\circ}\text{C}$			410	nA	
C_{ies}	Input capacitance	$f = 1\text{ MHz}, T_{vj} = 25^{\circ}\text{C}, V_{CE} = 25\text{ V},$		1.29		nF	
C_{res}	Reverse transfer capacitance	$V_{GE} = 0\text{ V}$		41		pF	
$t_{d(on)}$	Turn-on Delay Time, Inductive Load	$I_C=15\text{ A}, V_{CE}=600\text{ V}$ $V_{GE}=\pm 15\text{ V}$ $R_G=35\Omega$ $T_{vj}=25^{\circ}\text{C}$		94		ns	
t_r	Rise Time, Inductive Load			52		ns	
$t_{d(off)}$	Turn-off Delay Time, Inductive Load			243		ns	
t_f	Fall Time, Inductive Load			190		ns	
E_{on}	Turn-on Energy Loss per Pulse				1.95		mJ
E_{off}	Turn-off Energy Loss per Pulse				0.81		mJ
$t_{d(on)}$	Turn-on Delay Time, Inductive Load				85		ns
t_r	Rise Time, Inductive Load				114		ns
$t_{d(off)}$	Turn-off Delay Time, Inductive Load				202		ns
t_f	Fall Time, Inductive Load				312		ns
E_{on}	Turn-on Energy Loss per Pulse	$T_{vj}=125^{\circ}\text{C}$		2.1		mJ	
E_{off}	Turn-off Energy Loss per Pulse			1.2		mJ	
R_{thJC}	Thermal resistance, junction to case	per IGBT			1.15	K/W	
$T_{vj\text{ op}}$	Temperature under switching conditions		-40		125	$^{\circ}\text{C}$	
I_{sc}	SC	$V_{GE}\leq 15\text{ V}, V_{CE}=600\text{ V}, t_p\leq 10\mu\text{s},$ $T_{vj}=125^{\circ}\text{C},$ $V_{CE\max}=V_{CES}-L_{SCE}\cdot di/dt$		60		A	

Maximum Rated Values (Diode Brake-Chopper)

Symbol	Parameter	Conditions	Min.	Typ.	Max.	Unit
V_{RRM}	Repetitive Peak Reverse Voltage	$T_{vj}=25\text{ }^{\circ}\text{C}$		1200		V
I_F	Continuous DC Forward Current			15		A
I_{FRM}	Repetitive Peak Forward Current	$t_p=1\text{ ms}$		30		A
I^2t	I^2t Value	$V_R=0\text{ V}, t_p=10\text{ ms}, T_{vj}=150\text{ }^{\circ}\text{C}$		15		A ² s

Characteristics (Diode Brake-Chopper)

Symbol	Parameter	Conditions	Min.	Typ.	Max.	Unit
V_F	Forward Voltage	$I_F=15\text{ A}, V_{CE}=0\text{ V}, T_{vj}=25\text{ }^{\circ}\text{C}$		1.9	2.5	V
		$I_F=15\text{ A}, V_{CE}=0\text{ V}, T_{vj}=125\text{ }^{\circ}\text{C}$		1.90		V
t_{rr}	Reverse Recovery time	$I_F=15\text{ A}, V_R=600\text{ V}$ $-di/dt=300\text{ A/us}$ $T_{vj}=25\text{ }^{\circ}\text{C}$		220		ns
Q_r	Recovered Charge			0.8		μC
E_{rec}	Reverse Recovery Energy				0.2	
t_{rr}	Reverse Recovery time	$I_F=15\text{ A}, V_R=600\text{ V}$ $-di/dt=300\text{ A/us}$ $T_{vj}=125\text{ }^{\circ}\text{C}$		370		ns
Q_r	Recovered Charge			1.4		μC
E_{rec}	Reverse Recovery Energy				0.4	
R_{thJC}	Thermal resistance, junction to case				1.75	K/W
$T_{vj\text{ op}}$	Temperature under switching conditions		-40		125	$^{\circ}\text{C}$

NTC-Thermistor (Characteristic Values)

Symbol	Parameter	Conditions	Min.	Typ.	Max.	Unit
R ₂₅	Rated resistance	T _c =25 °C		5		KΩ
ΔR/R	Deviation of R100	T _c =100 °C	-5		5	%
P ₂₅	Power dissipation	T _c =25 °C		20		mW
B _{25/50}	B-value	$R_2=R_{25}\exp[B_{25/50}(1/T_2-1/(298,15K))]$		3380		K
B _{25/100}	B-value	$R_2=R_{25}\exp[B_{25/100}(1/T_2-1/(298,15K))]$		3450		K

Module Characteristics

Symbol	Parameter	Conditions	Min.	Typ.	Max.	Unit
V _{isol}	Isolation voltage	t=1min,f=50Hz	2500			V
T _{stg}	Storage Temperature		-40		125	°C
F	Mounting Force per Clamp		20		50	N
G	Weight of Module			25		g

Output characteristic of IGBT, Inverter (typical)

$I_c = f(V_{CE})$

$V_{GE} = 15V$

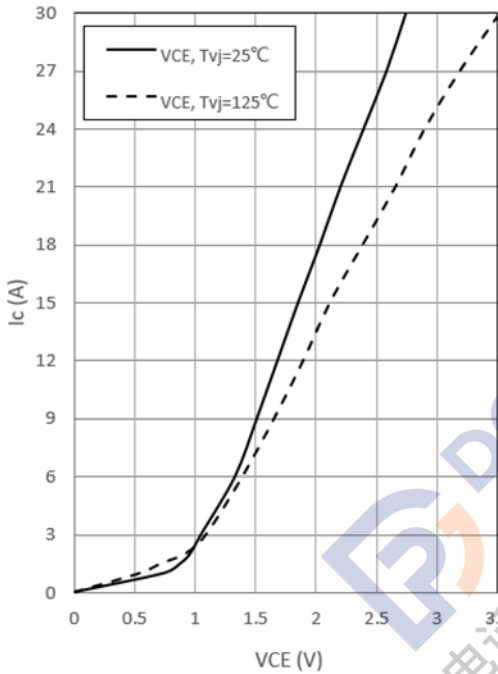

Switching time of IGBT, Inverter (typical)

$E_{on} = f(I_c), E_{off} = f(I_c)$

$V_{GE} = \pm 15V, R_G = 35\Omega, V_{CE} = 600V$

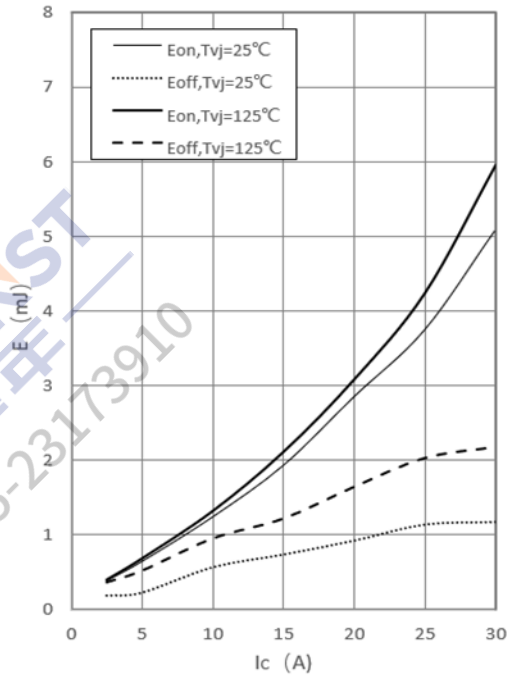

Switching losses of IGBT, Inverter (typical)

$E_{on} = f(R_G), E_{off} = f(R_G)$

$V_{GE} = \pm 15V, I_c = 15A, V_{CE} = 600V$

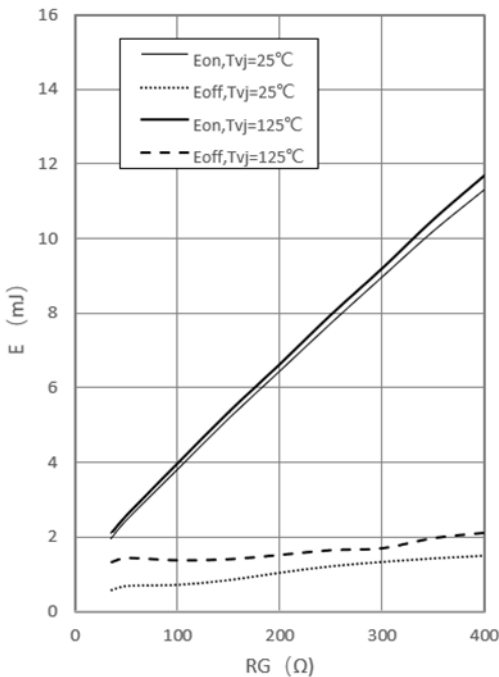

RBSOA IGBT, Inverter (typical)

$I_c = f(V_{CE})$

$V_{GE} = \pm 15V, R_{Goff} = 35\Omega, T_{vj} = 125^\circ C$

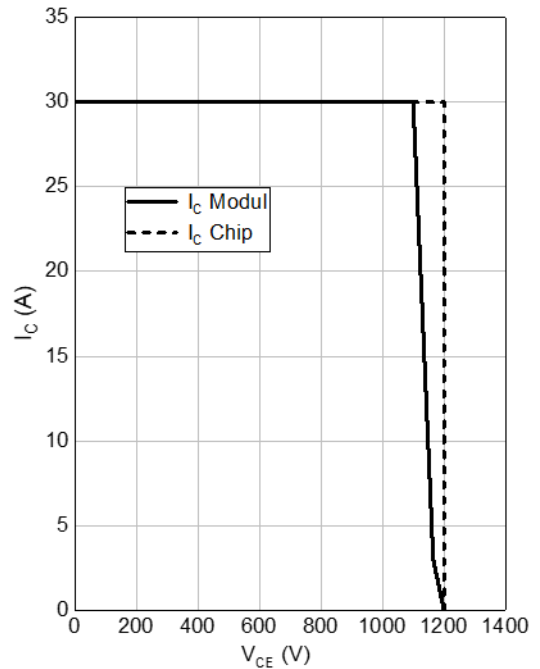

Forward characteristic of Diode, Inverter (typical)

$$I_F = f(V_F)$$

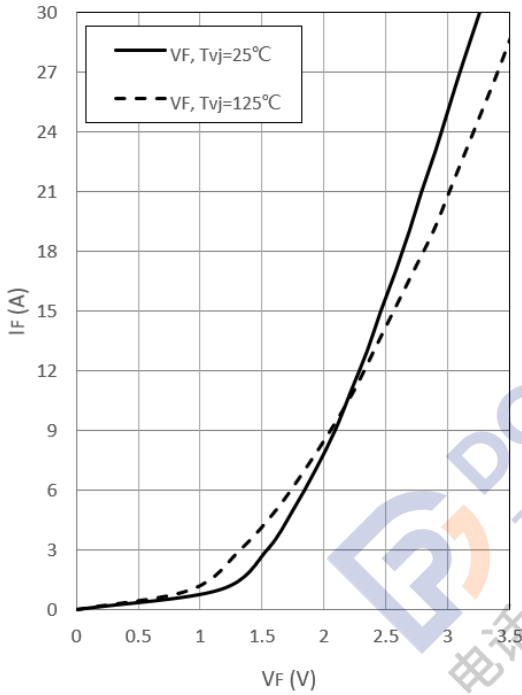

Switching losses of Diode, Inverter (typical)

$$E_{rec} = f(R_G)$$

$$I_F = 15\text{A}, V_{CE} = 600\text{V}$$

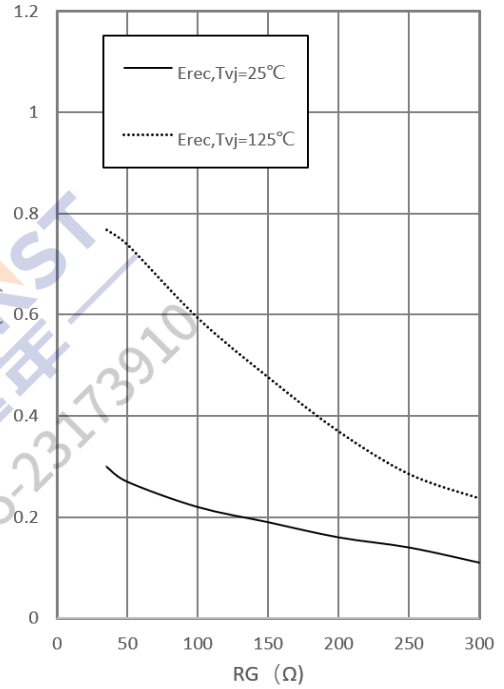

Switching losses of Diode, Inverter (typical)

$$E_{rec} = f(I_F)$$

$$R_G = 35\Omega, V_{CE} = 600\text{V}$$

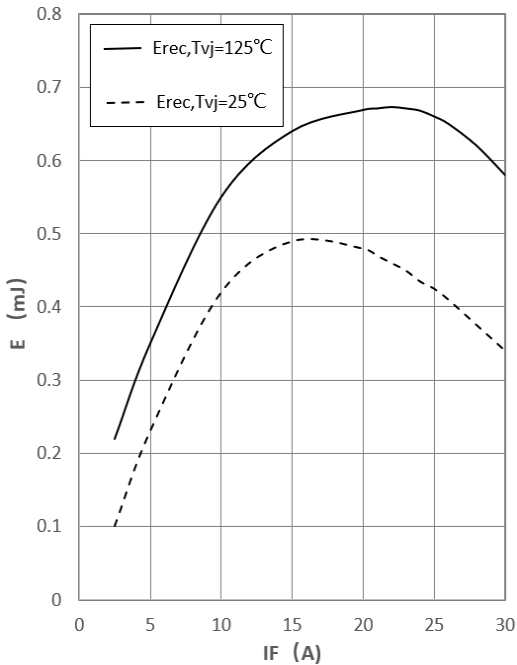

Output characteristic of IGBT, Brake-Chopper, (typical)

$$I_c = f(V_{CE})$$

$$V_{GE} = 15\text{V}$$

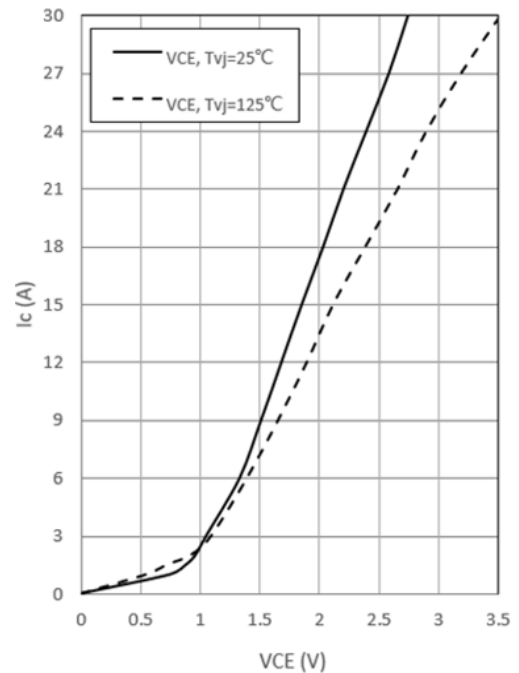

Output characteristic of IGBT, Brake-Chopper, (typical)

$$I_c = f(V_{CE})$$

$$V_{GE} = 15V$$

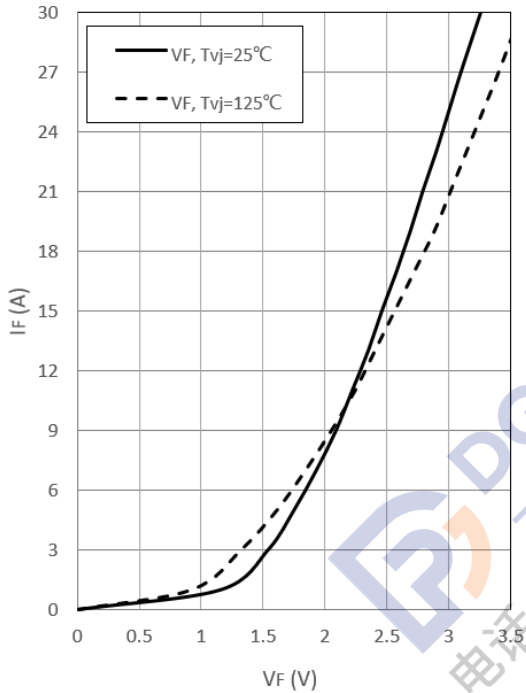

Forward characteristic of Diode, Rectifier (typical)

$$I_F = f(V_F)$$

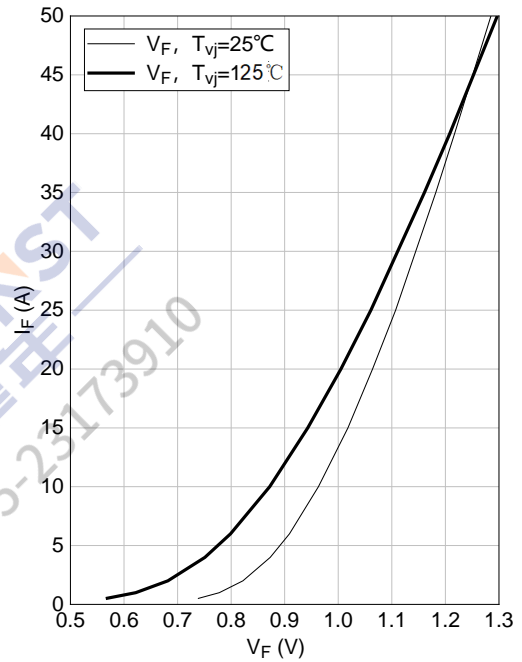

NTC-thermistor-temperature characteristic (typical)

$$R = f(T_{NTC})$$

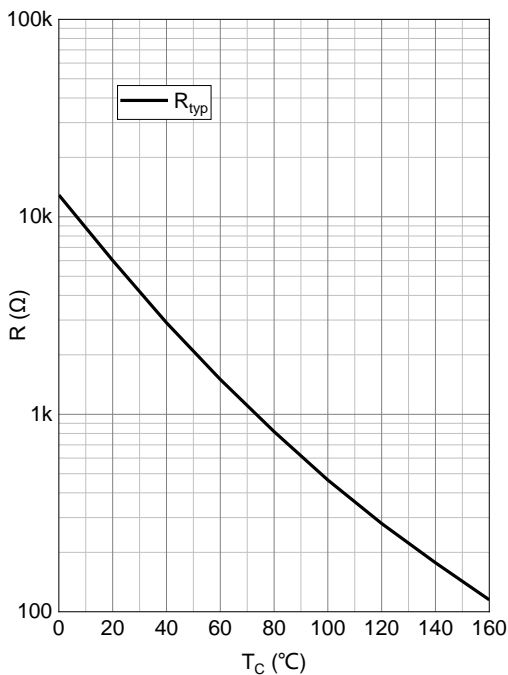

Circuit Diagram

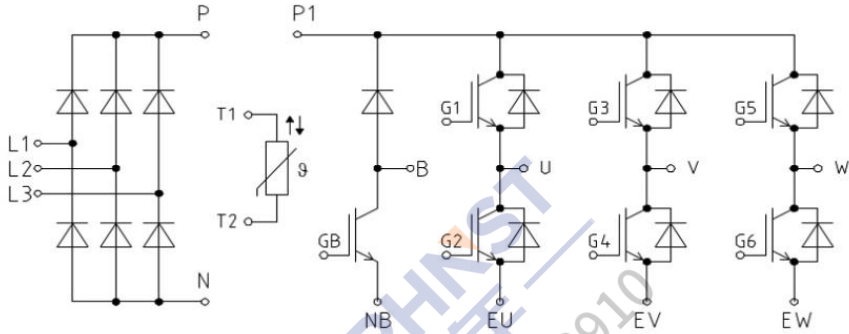

Package Dimensions

(Dimensions in Millimeters)

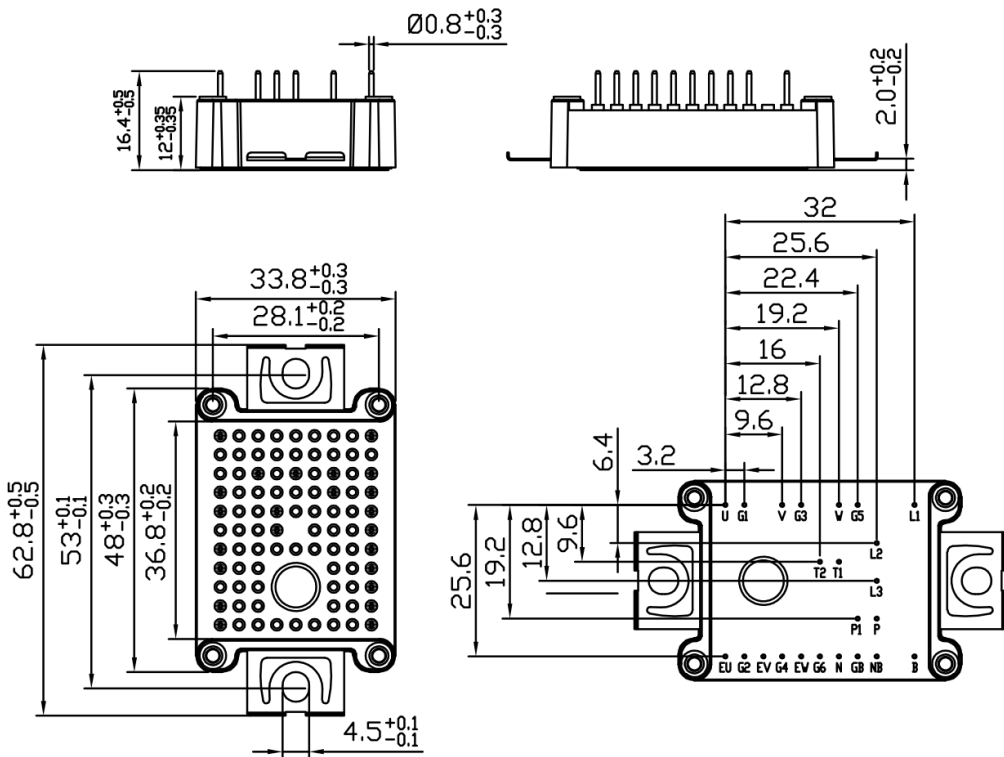

DISCLAIMER

ALL PRODUCT, PRODUCT SPECIFICATIONS AND DATA ARE SUBJECT TO CHANGE WITHOUT NOTICE TO IMPROVE RELIABILITY, FUNCTION OR DESIGN OR OTHERWISE

