

Description

Silicon Carbide (SiC) MOSFET use a completely new technology that provide superior switching performance and higher reliability compared to Silicon. In addition, the low ON resistance and compact chip size ensure low capacitance and gate charge. Consequently, system benefits include highest efficiency, faster operating frequency, increased power density, reduced EMI, and reduced system size.

Features

- High Speed Switching with Low Capacitances
- High Blocking Voltage with Low RDS(on)
- Easy to parallel and simple to drive
- ROHS Compliant, Halogen free

Application

- EV Charging
- DC/DC Converters
- Switch Mode Power Supplies
- Power Factor Correction Modules
- Solar PV inverters

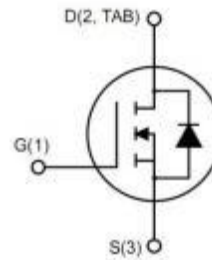
Ordering Information

Part Number	Marking	Package	Packaging
JX3S0020R065M	JX3S0020R065M	TO247-3	Tube

Absolute Maximum Ratings(Tc=25°C)

Symbol	Parameter	Value	Unit
V _{DS}	Drain-Source Voltage	650	V
I _D	Drain Current(continuous)at T _c =25°C	100	A
I _D	Drain Current(continuous)at T _c =100°C	60	A
I _{DM}	Drain Current (pulsed)	300	A
V _{GS}	Gate-Source Voltage	-10/+22	V
P _D	Power Dissipation T _c = 25°C	450	W
T _J , T _{stg}	Junction and Storage Temperature Range	-55 to +150	°C

Electrical Characteristics(T_J = 25°C unless otherwise specified)
Typical Performance-Static

Symbol	Parameter	Test Conditions	Min.	Typ.	Max.	Unit
BV _{DS}	Drain-source Breakdown Voltage	I _D =250uA, V _{GS} =0V	650			V
I _{DSS}	Zero Gate Voltage Drain Current	V _{DS} =650V, V _{GS} =0V, T _J =25°C			100	μA
I _{GSS}	Gate-body Leakage Current	V _{DS} =0V ; V _{GS} = -10 to 20V		10	250	nA
V _{GS(th)}	Gate Threshold Voltage	V _{DS} = V _{GS} , I _D =15mA	2	3	4	V
V _{GSon}	Recommended turn-on Voltage	Static		20		V
V _{GSoff}	Recommended turn-off Voltage			-5		V
R _{DS(on)}	Static Drain-source On Resistance	V _{GS} =20V, I _D =50A		15	21	mΩ
		V _{GS} =20V, I _D =50A T _J =150°C		19		mΩ

Typical Performance-Dynamic

Symbol	Parameter	Test Conditions	Min.	Typ.	Max.	Unit
C_{iss}	Input Capacitance	$V_{DS}=400V, f=1KHz,$ $V_{AC}=25mV$		5315		pF
C_{oss}	Output Capacitance			325		pF
C_{riss}	Reverse Transfer Capacitance			31		pF
g_{fs}	Transconductance	$V_{DS}=20V, I_D=15A$		42		S
E_{OSS}	C_{oss} Stored Energy	$V_{DS}=400V, f=1KHz$		32		μJ
E_{ON}	Turn-On Energy (Body Diode)	$V_{DS}=400V, V_{GS}=-5/20V,$ $I_D=50A, L=68\mu H$ $T_J=150^\circ C$		1565		μJ
E_{OFF}	Turn-Off Energy (Body Diode)			800		μJ
Q_g	Total Gate Charge	$V_{DS}=400V, V_{GS}=-5V/20V,$ $I_D=50A$		236		nC
Q_{gs}	Gate-source Charge			56		nC
Q_{gd}	Gate-Drain Charge			64		nC
$R_{G(int)}$	Internal Gate Resistance	$f=1MHz, V_{AC}=25mV$		3.5		Ω
$t_{d(on)}$	Turn-on Delay Time	$V_{DS}=400V, V_{GS}=-5V/20V,$ $I_D=50A, L=68\mu H$		25		ns
t_r	Rise Time			136		ns
$t_{d(off)}$	Turn-off Delay Time	$R_{ext}=5\Omega$		63		ns
t_f	Fall Time			27		ns

Typical Performance-Reverse Diode($T_J = 25^\circ C$ unless otherwise specified)

Symbol	Parameter	Test Conditions	Min.	Typ.	Max.	Unit
V_{FSD}	Forward Voltage	$V_{GS}=0V, I_F=25A, T_J=25^\circ C$		4.8	6	V
		$V_{GS}=0V, I_F=25A, T_J=150^\circ C$		4.2	6	V
I_S	Continuous Diode Forward Current	$V_{GS}=0V, T_C=25^\circ C$		80		A
t_{rr}	Reverse Recovery Time	$V_{GS}=-5V, I_F=25A,$ $V_R=400V, T_J=150^\circ C$ $di/dt=2400A/\mu s$		88		nS
Q_{rr}	Reverse Recovery Charge			680		nC
I_{rrm}	Peak Reverse Recovery Current			17		A

Thermal Characteristics

Symbol	Parameter	Value.	Unit
$R_{\theta JC}$	Thermal Resistance, Junction-to-Case	0.28	$^\circ C/W$
$R_{\theta JA}$	Thermal Resistance, Junction-to-Ambient	40	$^\circ C/W$

The values are based on the junction-to case thermal impedance which is measured with the device mounted to a large heat sink assuming maximum junction temperature of $T_J(max)=150^\circ C$

Electrical Characteristics

Fig1. Output characteristics ($T_J = 25^\circ\text{C}$)

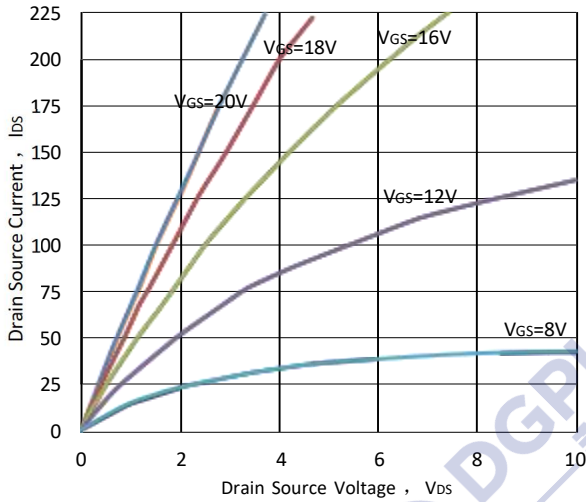

Fig2. Output characteristics ($T_J = 150^\circ\text{C}$)

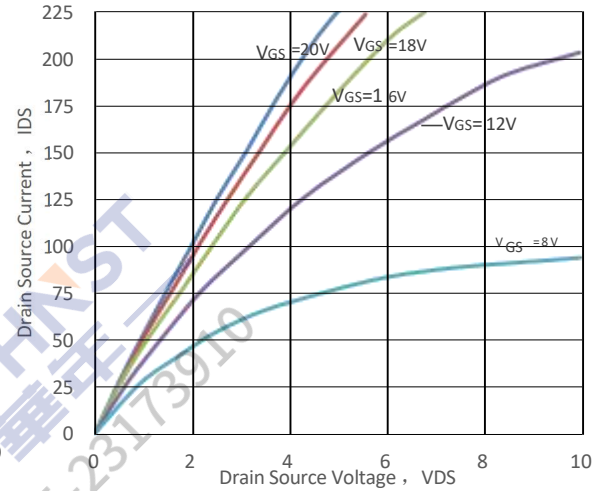

Fig3. Normalized On-Resistance vs. Temperature

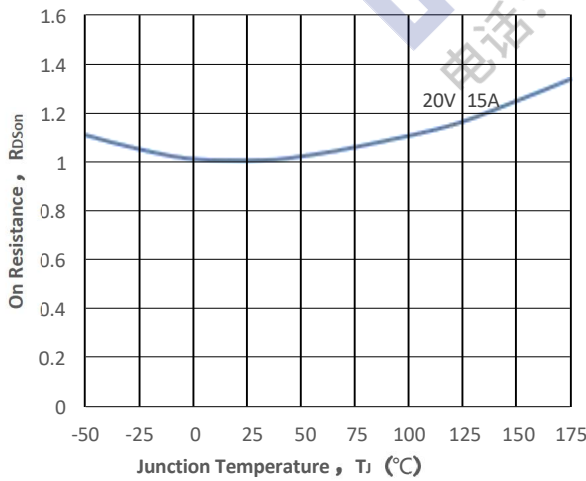

Fig4. On-Resistance vs. Temperature

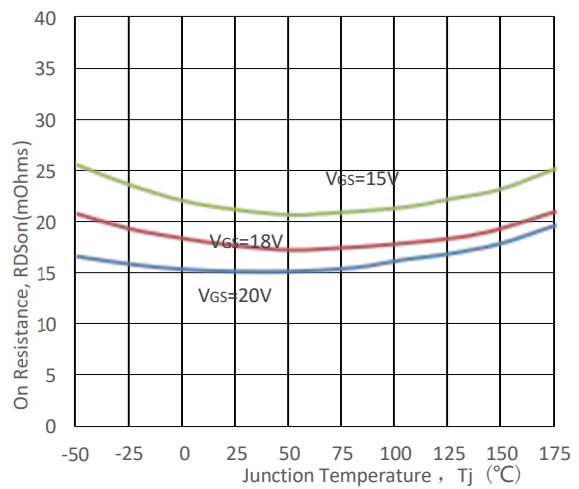

Fig5. Transfer Characteristic

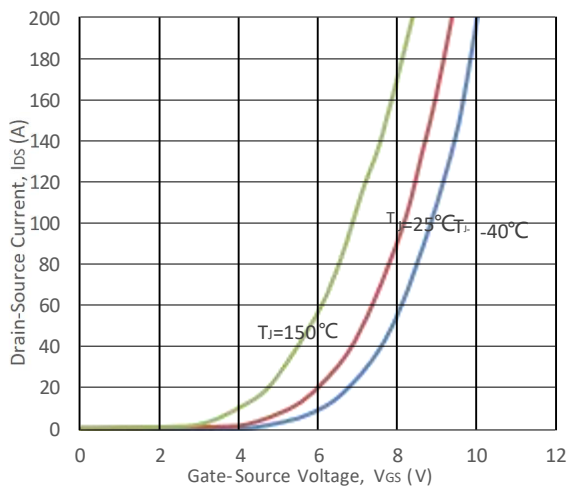

Fig6. Body Diode Characteristic at 25°C

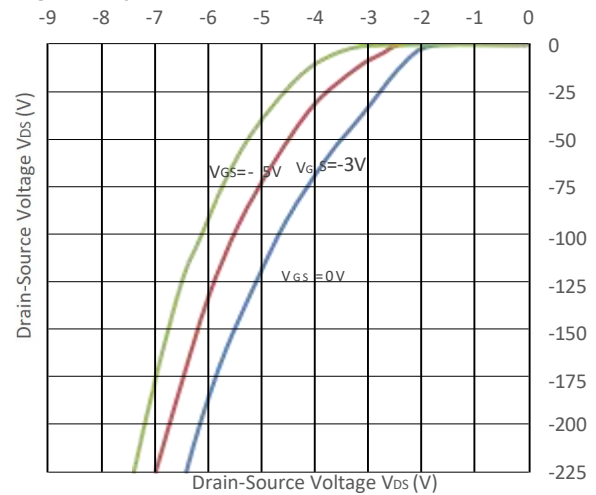

Fig7. Threshold Voltage vs. Temperature

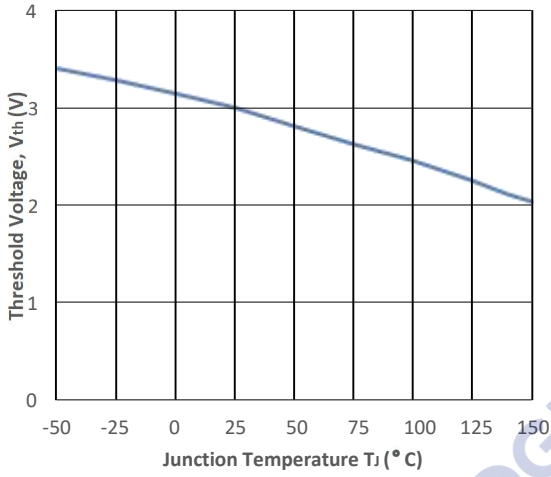

Fig8. Gate Charge Characteristics

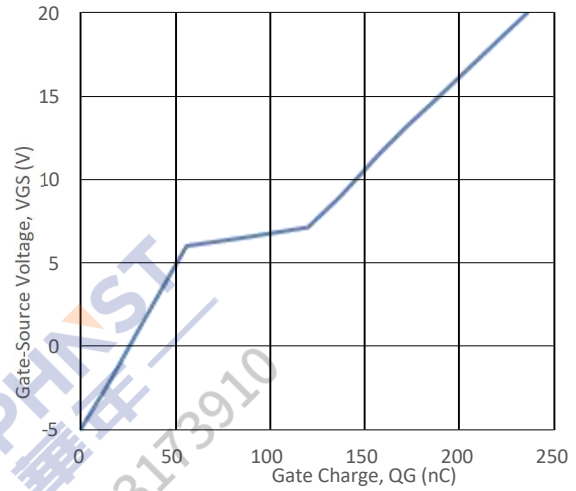

Fig9. 3rd Quadrant Characteristic at 25 $^{\circ}$ C

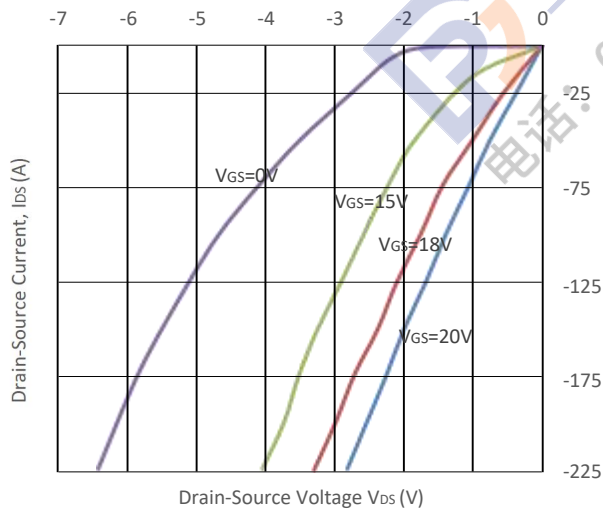

Fig10. Output Capacitor Stored Energy

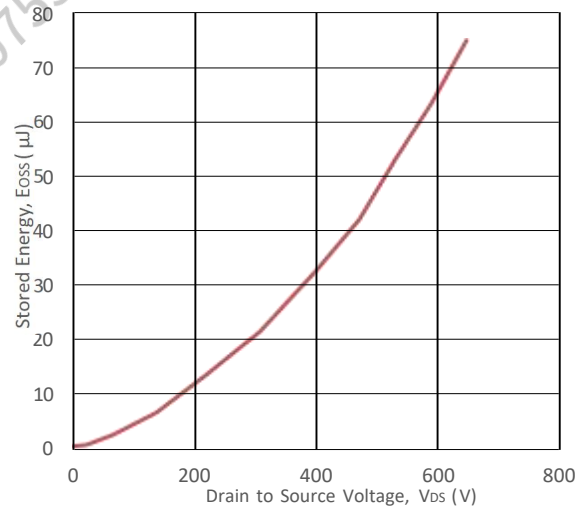

Fig11. Capacitances vs. Drain-Source

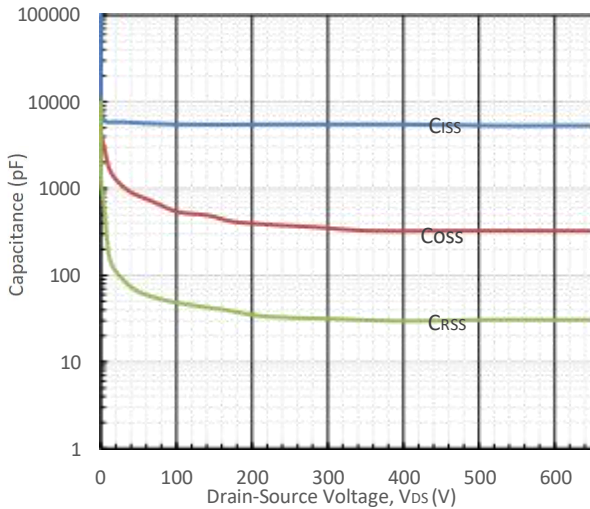

Fig12. Max Power Dissipation Derating Vs T_c

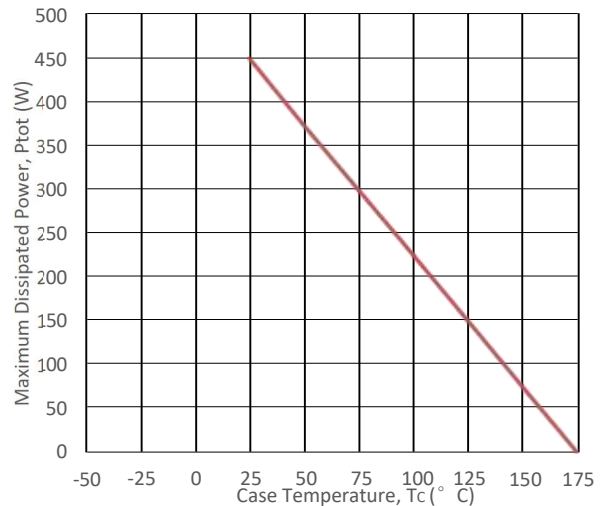

Fig13. Switching Energy vs. Drain Current

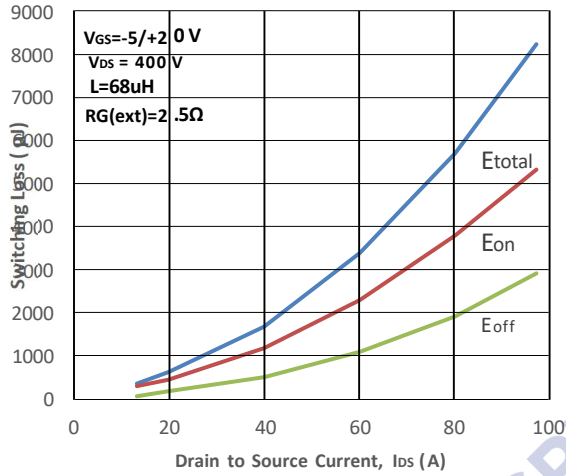

Fig14. Switching Energy vs. RG(ext)

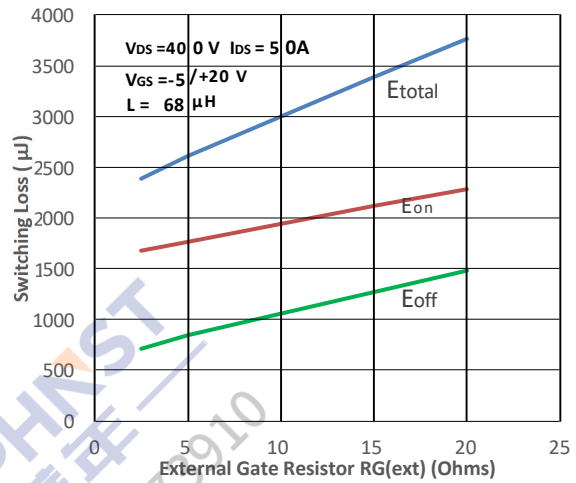

Fig15. Switching Energy vs. Temperature

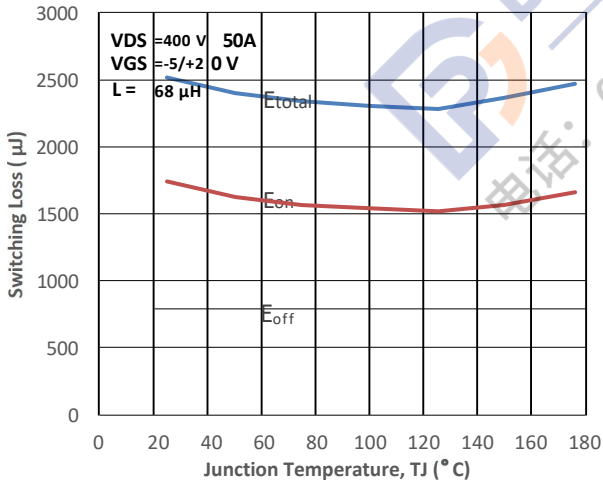

Fig16. Switching Times vs. RG(ext)

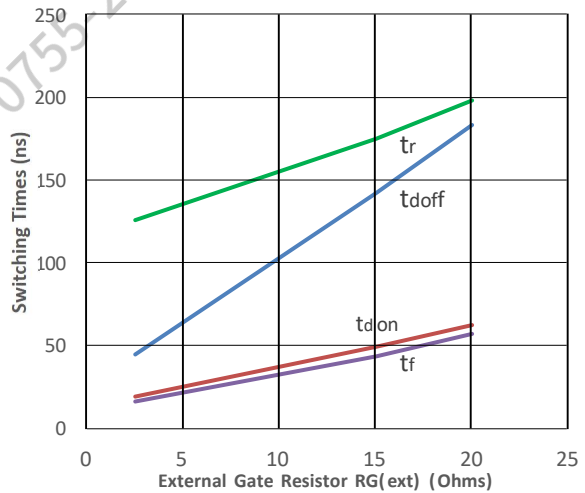

Fig17. Transient Thermal Impedance

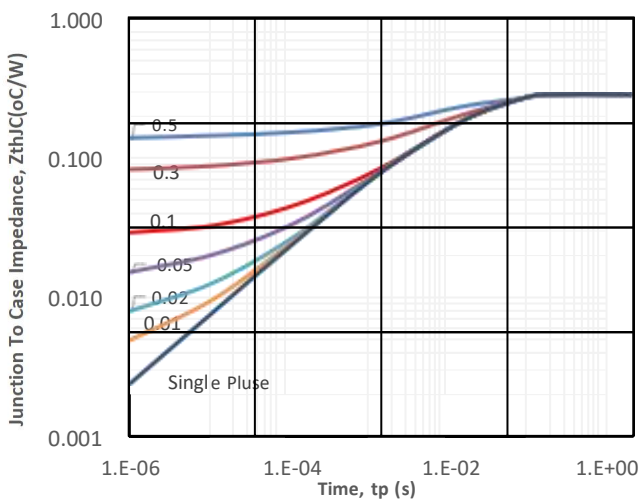
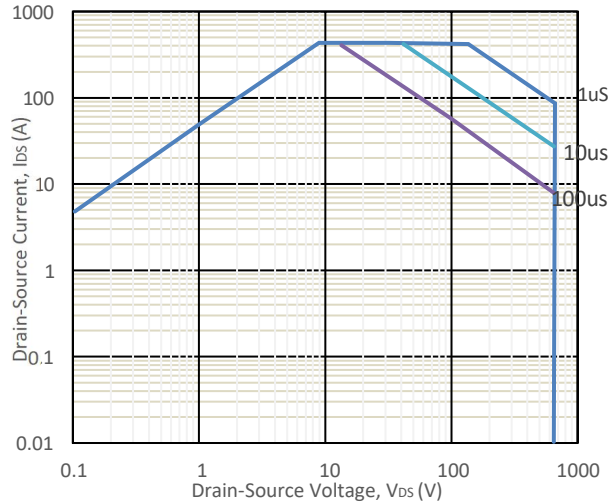
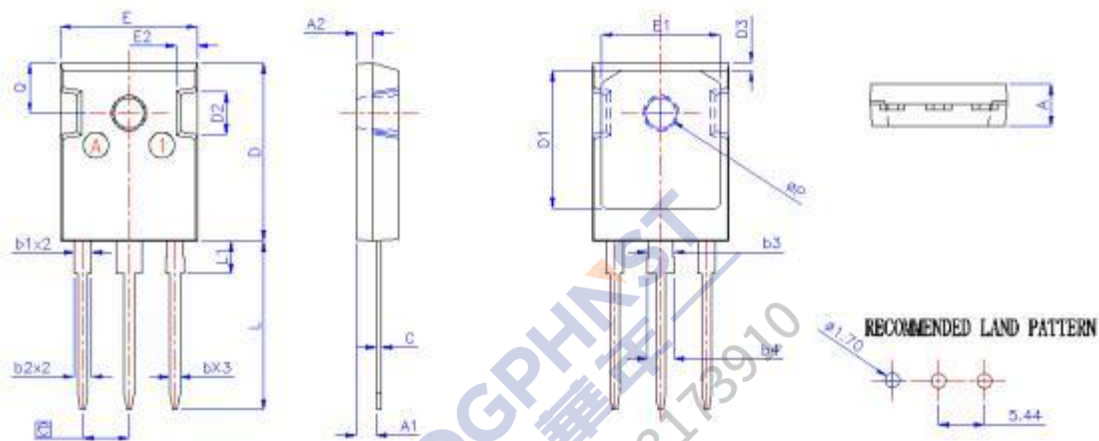

Fig18. Safe Operating Area



Package Drawing:

Dimensions (UNIT: mm)

SYMBDLS	DIMENSIONS IN MILLIMETERS			DIMENSIONS IN INCHES		
	MIN	NOM	MAX	MIN	NOM	MAX
A	4.90	5.00	5.10	0.193	0.197	0.201
A1	2.31	2.42	2.52	0.091	0.095	0.099
A2	1.90	2.00	2.10	0.075	0.079	0.083
b	1.16	1.22	1.27	0.046	0.048	0.050
b1	1.96	2.02	2.07	0.079	0.080	0.081
b2	2.03	2.07	2.10	0.080	0.0815	0.083
b3	2.96	3.02	3.07	0.117	0.119	0.121
b4	3.03	3.07	3.1	0.119	0.120	0.122
C	0.59	0.62	0.66	0.023	0.024	0.026
D	20.90	21.00	21.10	0.823	0.827	0.831
D1	15.96	16.26	16.56	0.628	0.640	0.652
D2	4.3			4.3		
D3	0.8	0.95	1.1	0.031	0.037	0.043
e	5.44 BSC			0.214 BSC		
E	15.95	16.15	16.35	0.628	0.636	0.644
E1	13.82	14.02	14.26	0.544	0.552	0.561
E2	4.3			0.169		
L	19.72	19.92	20.12	0.776	0.784	0.792
L1	---	---	3.86	---	---	0.152
Q	5.95 BSC			0.234 BSC		
ØP	3.55	3.60	3.70	0.140	0.142	0.146