

Description

Silicon Carbide (SiC) MOSFET use a completely new technology that provide superior switching performance and higher reliability compared to Silicon. In addition, the low ON resistance and compact chip size ensure low capacitance and gate charge. Consequently, system benefits include highest efficiency, faster operating frequency, increased power density, reduced EMI, and reduced system size.

Features

- High Speed Switching with Low Capacitances
- High Blocking Voltage with Low RDS(on)
- Optimized package with separate driver source pin
- Easy to parallel and simple to drive
- ROHS Compliant, Halogen free

Application

- EV motor drive
- High Voltage DC/DC Converters
- Switch Mode Power Supplies
- Solar inverters
- EV charging

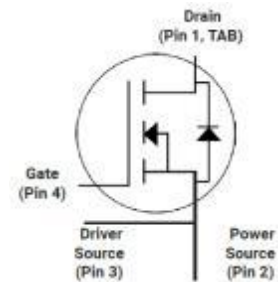
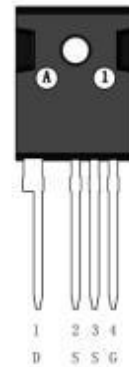
Ordering Information

Part Number	Marking	Package	Packaging
JX4S0020R120M	JX4S0020R120M	TO-247	Tube

Absolute Maximum Ratings(Tc=25°C)

Symbol	Parameter	Value	Unit
V _{DS}	Drain-Source Voltage	1200	V
I _D	Drain Current(continuous)at Tc=25°C	115	A
I _D	Drain Current(continuous)at Tc=100°C	85	A
I _{DM}	Drain Current (pulsed)	250	A
V _{GS}	Gate-Source Voltage	-10/+22	V
P _D	Power Dissipation Tc = 25°C	550	W
T _J , T _{stg}	Junction and Storage Temperature Range	-55 to +150	°C

Electrical Characteristics(T_J = 25°C unless otherwise specified)
Typical Performance-Static

Symbol	Parameter	Test Conditions	Min.	Typ.	Max.	Unit
BV _{DS}	Drain-source Breakdown Voltage	I _D =250uA, V _{GS} =0V	1200			V
I _{DSS}	Zero Gate Voltage Drain Current	V _{DS} =1200V, V _{GS} =0V, T _J =25°C		5	100	uA
I _{GSS}	Gate-body Leakage Current	V _{DS} =0V ; V _{GS} =-10 to 20V		10	250	nA
V _{GS(th)}	Gate Threshold Voltage	V _{DS} = V _{GS} , I _D =22mA	2	3	4	V
V _{GSon}	Recommended turn-on Voltage	Static		20		V
V _{GSoff}	Recommended turn-off Voltage			-5		V
R _{DS(on)}	Static Drain-source On Resistance	V _{GS} =20V, I _D =50A		16	22	mΩ
		V _{GS} =20V, I _D =50A T _J =150°C		25.2		mΩ

Typical Performance-Dynamic

Symbol	Parameter	Test Conditions	Min.	Typ.	Max.	Unit	
C _{iss}	Input Capacitance	V _{DS} =1000V, f=1MHz, V _{AC} =25mV		6378		pF	
C _{oss}	Output Capacitance			245		pF	
C _{rss}	Reverse Transfer Capacitance			15		pF	
g _{fs}	Transconductance	V _{DS} =20V, I _D =50A		51		S	
E _{oss}	Coss Stored Energy	V _{DS} =1000V, f=1MHz		141		μJ	
E _{ON}	Turn-On Energy (Body Diode)	V _{DS} =800V, V _{GS} =-5/20V, I _D =50A, L=68μH		2.60		mJ	
E _{OFF}	Turn-Off Energy (Body Diode)	T _J =150°C		0.73		mJ	
Q _g	Total Gate Charge	V _{DS} =800V, V _{GS} =-5V/20V, I _D =50A		238		nC	
Q _{gs}	Gate-source Charge			76.7		nC	
Q _{gd}	Gate-Drain Charge			78.3		nC	
R _{G(int)}	Internal Gate Resistance	f=1MHz, V _{AC} =25mV		3.5		Ω	
t _{d(on)}	Turn-on Delay Time	V _{DS} =800V, V _{GS} =-5V/20V, I _D =50A, L=68 μH		42		ns	
t _r	Rise Time			34		ns	
t _{d(off)}	Turn-off Delay Time		R _{ext} =2.5Ω		71		ns
t _f	Fall Time				13		ns

Typical Performance-Reverse Diode(T_J = 25°C unless otherwise specified)

Symbol	Parameter	Test Conditions	Min.	Typ.	Max.	Unit
V _{FSD}	Forward Voltage	V _{GS} =0V, I _F =37.5A, T _J =25°C		4.6	6	V
		V _{GS} =0V, I _F =37.5A, T _J =150°C		4.2	6	V
I _S	Continuous Diode Forward Current	V _{GS} =0V, T _C =25°C		110		A
t _{rr}	Reverse Recovery Time	V _{GS} =-5V, I _F =50A, V _R =800V, di/dt=900		98		nS
Q _{rr}	Reverse Recovery Charge			613		nC
I _{rrm}	Peak Reverse Recovery Current		A/μs, T _J =150°C		18	

Thermal Characteristics

Symbol	Parameter	Value.	Unit
R _{θJC}	Thermal Resistance, Junction-to-Case	0.23	°C/W
R _{θJA}	Thermal Resistance, Junction-to-Ambient	40	°C/W

The values are based on the junction-to case thermal impedance which is measured with the device mounted to a large heat sink assuming maximum junction temperature of T_{J(max)}=150°C

Electrical Characteristics

Fig1. Output characteristics ($T_J = 25\text{ }^\circ\text{C}$)

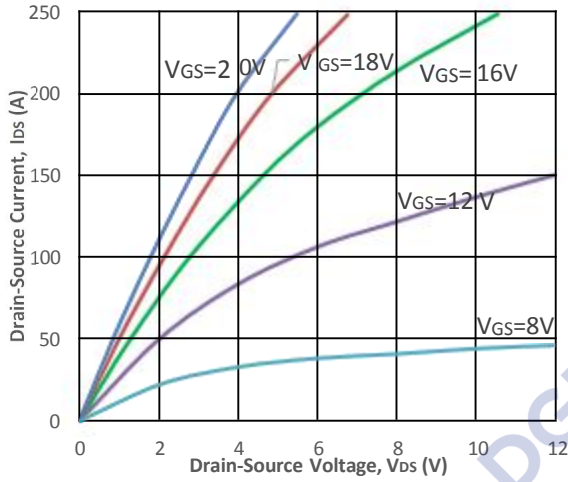

Fig2. Output characteristics ($T_J = 150\text{ }^\circ\text{C}$)

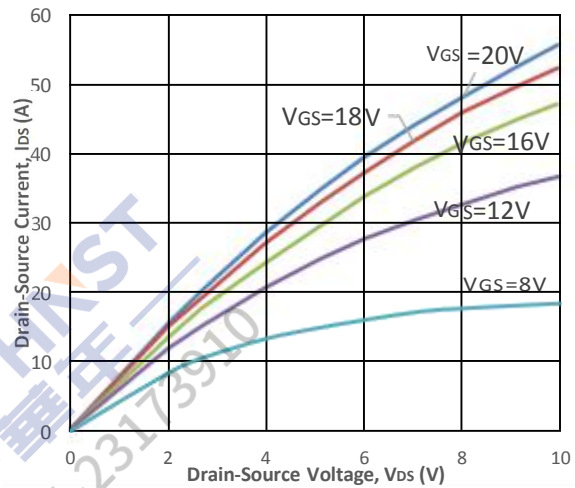

Fig3. Normalized On-Resistance vs. Temperature

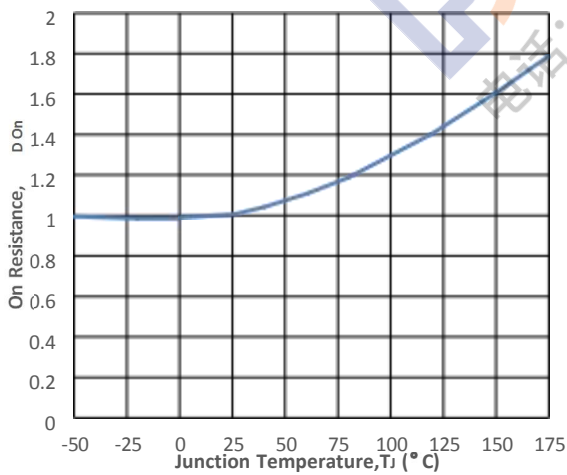

Fig4. On-Resistance vs. Temperature

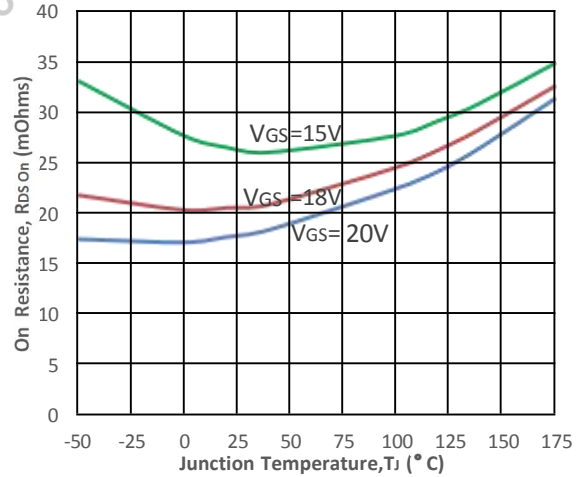

Fig5. Transfer Characteristic

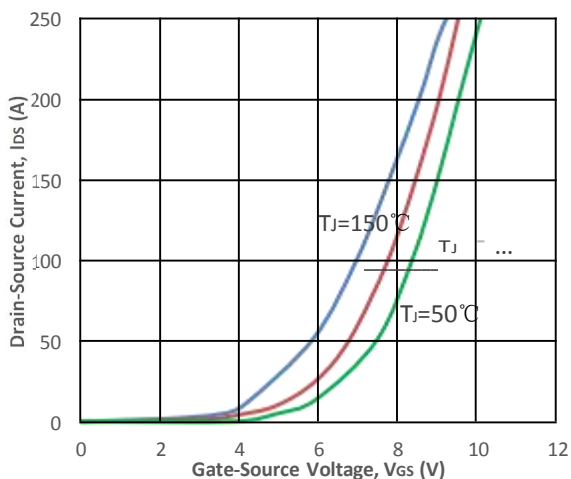

Fig6. Body Diode Characteristic at 25 °C

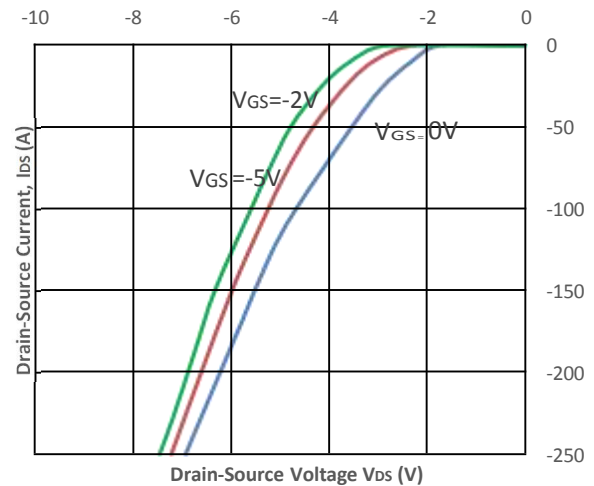

Fig7. Threshold Voltage vs. Temperature

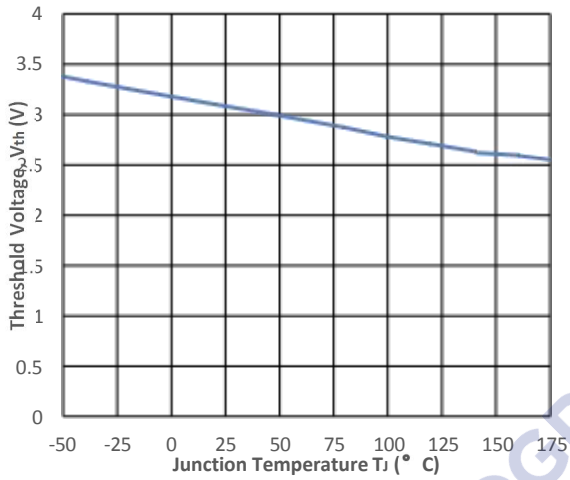

Fig8. Gate Charge Characteristics

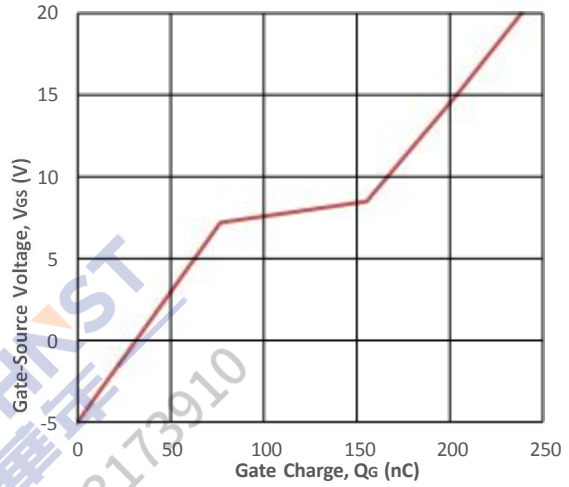

Fig9. 3rd Quadrant Characteristic at 25 $^{\circ}$ C

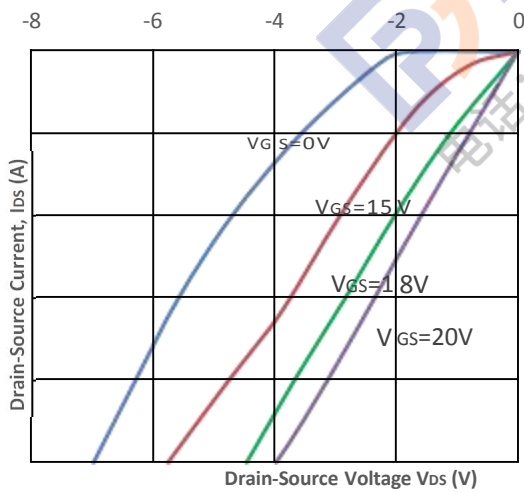

Fig10. Output Capacitor Stored Energy

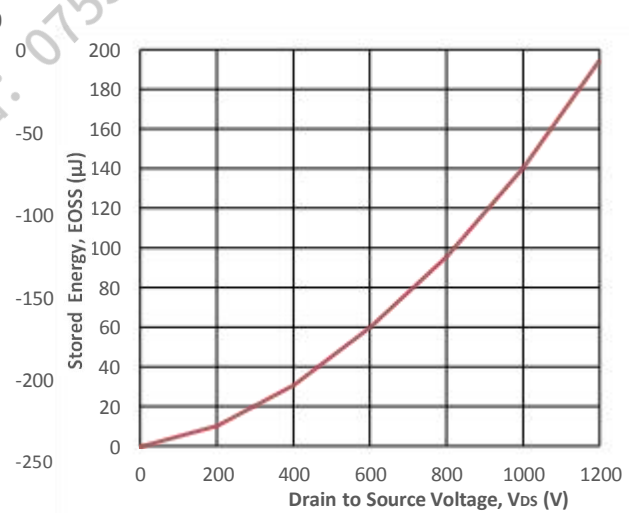

Fig11. Capacitances vs. Drain-Source

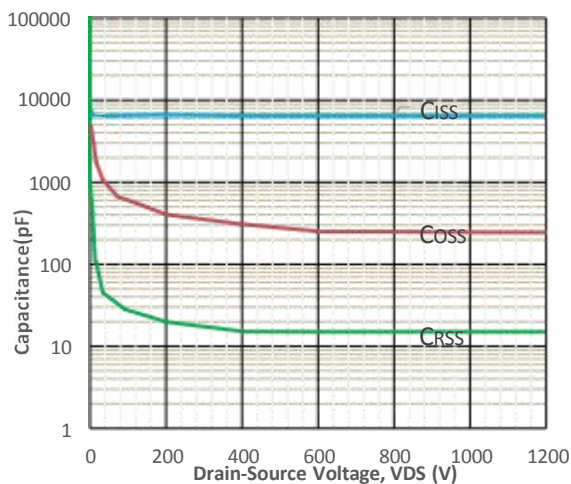

Fig12. Max Power Dissipation Derating Vs T_c

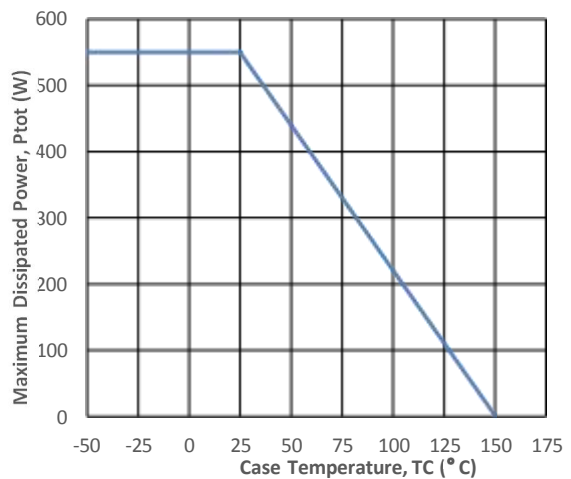

Fig13. Switching Energy vs. Drain Current

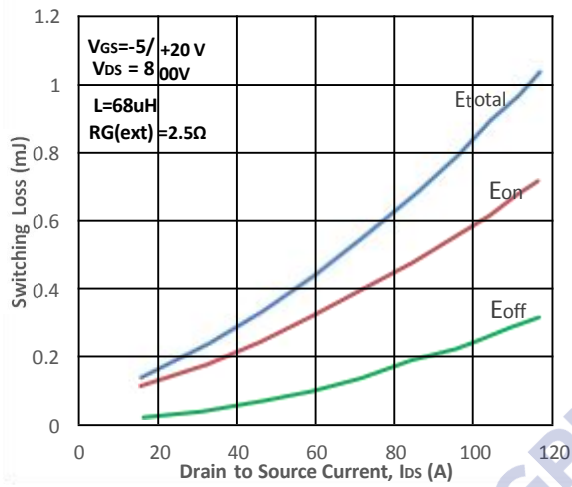

Fig14. Switching Energy vs. $R_{G(ext)}$

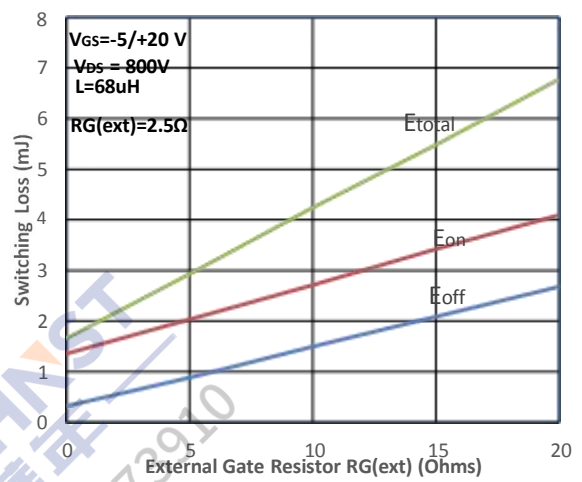

Fig15. Switching Energy vs. Temperature

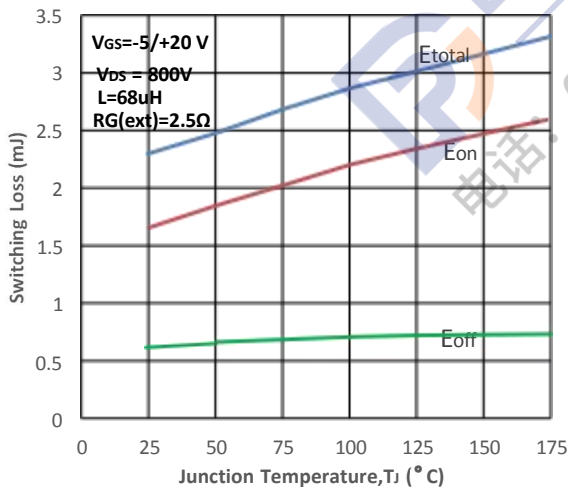

Fig16. Switching Times vs. $R_{G(ext)}$

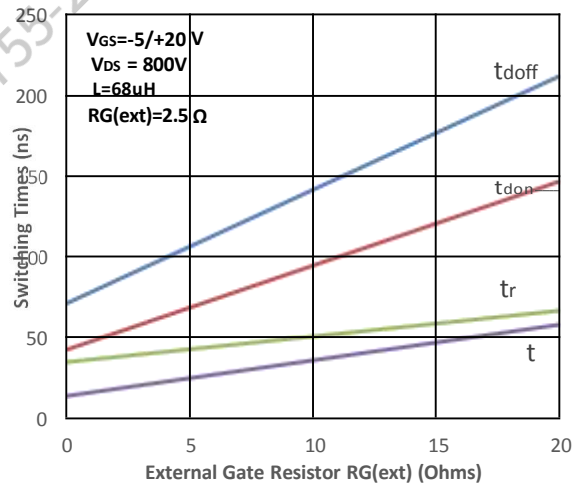

Fig17. Transient Thermal Impedance

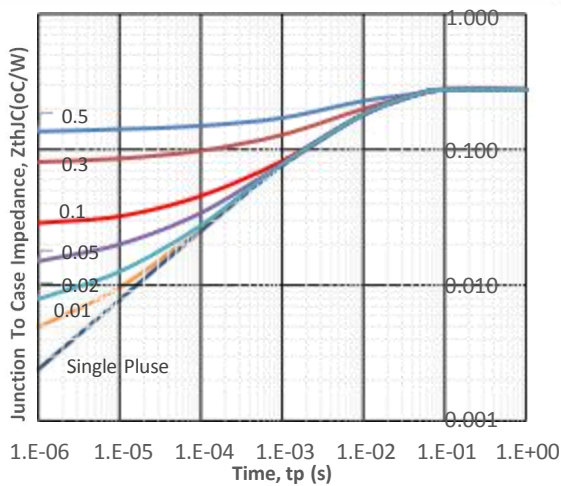
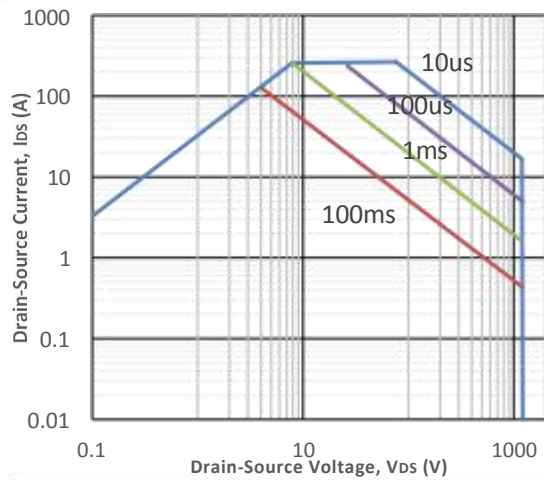
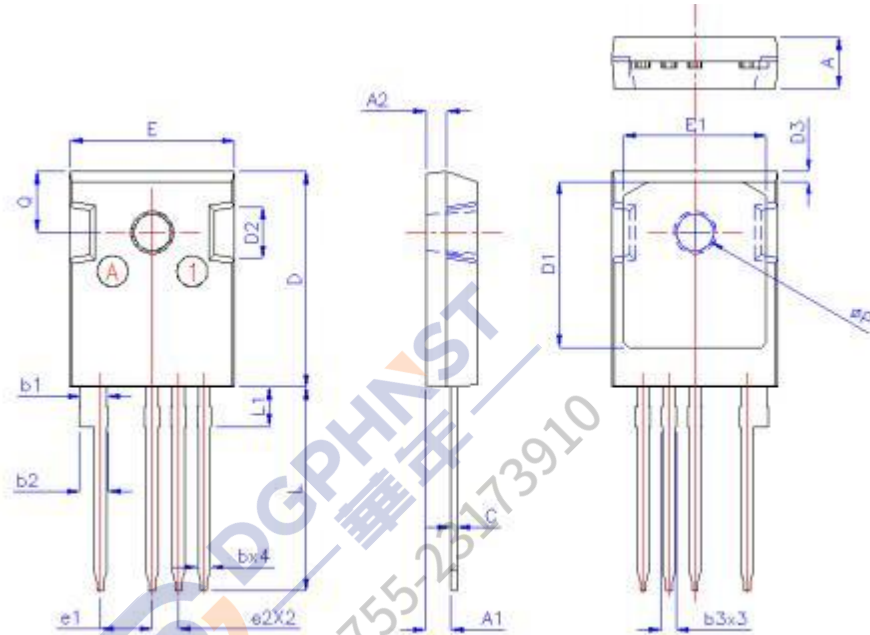

Fig18. Safe Operating Area



Package Drawing:

Dimensions (UNIT: mm)

SYMBDLS	DIMENSIONS IN MILLIMETERS			DIMENSIONS IN INCHES		
	MIN	NOM	MAX	MIN	NOM	MAX
A	4.9	5	5.1	0.193	0.197	0.201
A1	2.31	2.42	2.52	0.091	0.095	0.099
A2	1.9	2	2.1	0.075	0.079	0.083
b	1.16	1.22	1.27	0.046	0.048	0.050
b1	1.15	1.2	1.25	0.045	0.047	0.049
b2	2.61	2.76	2.91	0.103	0.109	0.115
b3	1.36	1.42	1.47	0.054	0.056	0.058
C	0.59	0.62	0.66	0.023	0.024	0.026
D	20.9	21	21.1	0.823	0.827	0.831
D1	15.94	16.24	16.54	0.628	0.639	0.651
D2		5		0.197 TYP		
D3	0.8	0.95	1.1	0.031	0.037	0.043
e	5.08 BSC			0.200 BSC		
e1	2.54 BSC			0.100BSC		
E	16.05	16.15	16.25	0.632	0.636	0.640
E1	13.82	14.02	14.26	0.544	0.552	0.561
L	19.75	19.95	20.15	0.778	0.785	0.793
L1	—	—	3.87	—	—	0.152
Q	5.95 BSC			0.234BSC		
ØP	3.45	3.6	3.75	0.136	0.142	0.148