



**2N7002AK**  
**0.3A 60V N-CHANNEL MOSFET**

**Features**

- Fast Switching Capability
- Avalanche Energy Tested
- Low On Resistance
- Low Input Capacitance
- Small Surface Mount Package

**Applications**

- Motor Control
- Power Management Functions

SOT-23

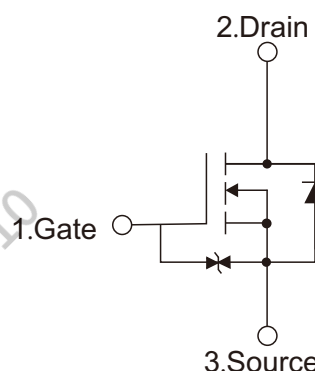
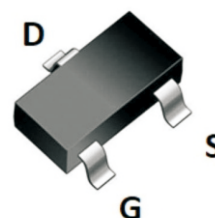

**Absolute Maximum Ratings (TA=25°C, unless otherwise specified)**

Parameter	Symbols	Ratings	Units
Drain-Source Voltage	$V_{DSS}$	60	V
Gate-Source Voltage	$V_{GSS}$	$\pm 20$	V
Continuous Drain Current	$I_D$	0.3	A
Operation Junction Temperature And Storage Temperature	$T_j, T_{stg}$	-55 ~ +150	$^{\circ}C$

Parameter	Symbols	Test Conditions	Min	Typ	Max	Units
<b>Off Characteristics</b>						
Drain-Source Breakdown Voltage	$B_{VDSS}$	$V_{GS} = 0V, I_D = 10\mu A$	60			V
Drain-Source Leakage Current	$I_{DSS}$	$V_{DS} = 60V, V_{GS} = 0V$			1	$\mu A$
Gate- Source Leakage Current	$I_{GSS}$	$V_{GS} = 20V, V_{DS} = 0V$			10	$\mu A$
		$V_{GS} = -20V, V_{DS} = 0V$			-10	
<b>On Characteristics</b>						
Gate Threshold Voltage	$V_{GS(TH)}$	$V_{DS} = V_{GS}, I_D = 250\mu A$	1.0	1.5	2.5	V
Static Drain-Source On-State Resistance	$R_{DS(ON)}$	$V_{GS} = 10V, I_D = 0.3A$		1.6	2.5	$\Omega$
		$V_{GS} = 4.5V, I_D = 0.2A$		1.9	3.0	$\Omega$
HBM	ESD	$V_{DS} = 10V, I_D = 0.115A$	2.0			KV



### Dynamic Characteristics

Input Capacitance	$C_{ISS}$	$V_{DS} = 25V,$ $V_{GS} = 0V,$ $f = 1.0MHz$	23	pF
Output Capacitance	$C_{OSS}$		3.4	pF
Reverse Transfer Capacitance	$C_{RSS}$		1.4	pF
<b>Switching Characteristics</b>				
Turn-On Delay Time	$t_{D(ON)}$	$V_{DD} = 30V, I_D = 3A, R_L = 150\Omega$ $V_{GEN} = 10, R_{GEN} = 25\Omega$	10	ns
Turn-Off Delay Time	$t_{D(OFF)}$		33	ns

### Typical Characteristics

Fig.1 Typical Output Characteristic

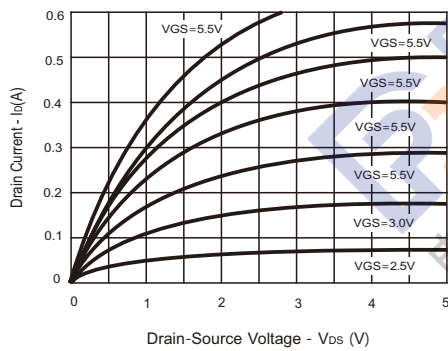

Fig.2 Typical Transfer Characteristics

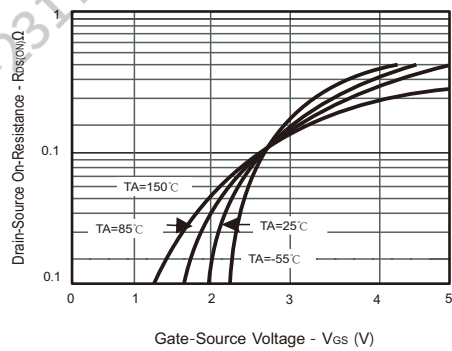

Fig.3 On-Resistance vs. Drain Current & Gate Voltage

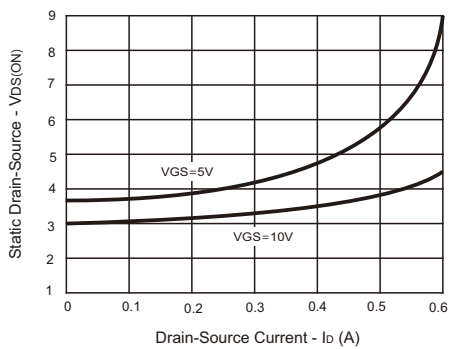

Fig.4 Normalized Static Drain-Source On-Resistance

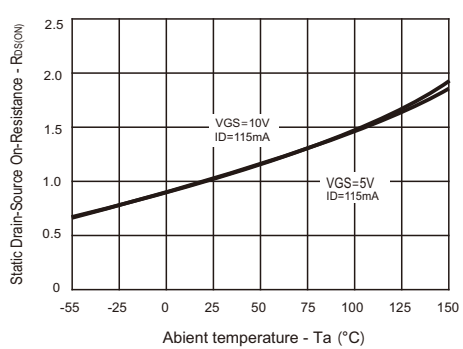



Fig.5 Gate Threshold Variation vs.Ambient Temperature

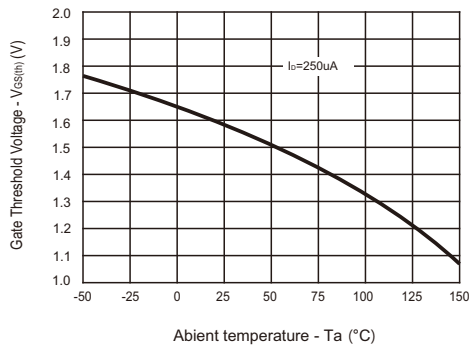

Fig.6 Typical Total Capacitance

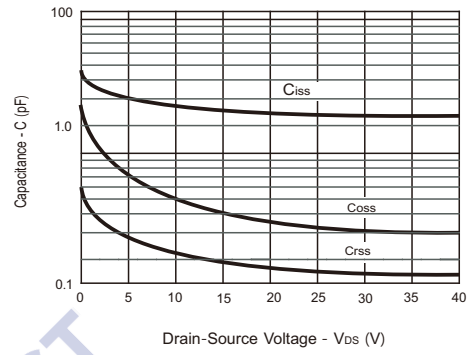
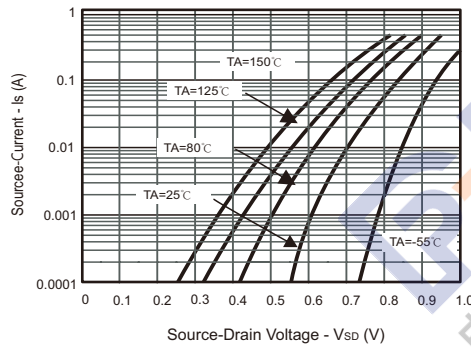

Fig.7 Reverse Dain Current vs.Source-Drain Voltage



DGPHNST  
— 華年 —  
电话: 0755-23173910



### SOT-23 Package Outline Dimensions

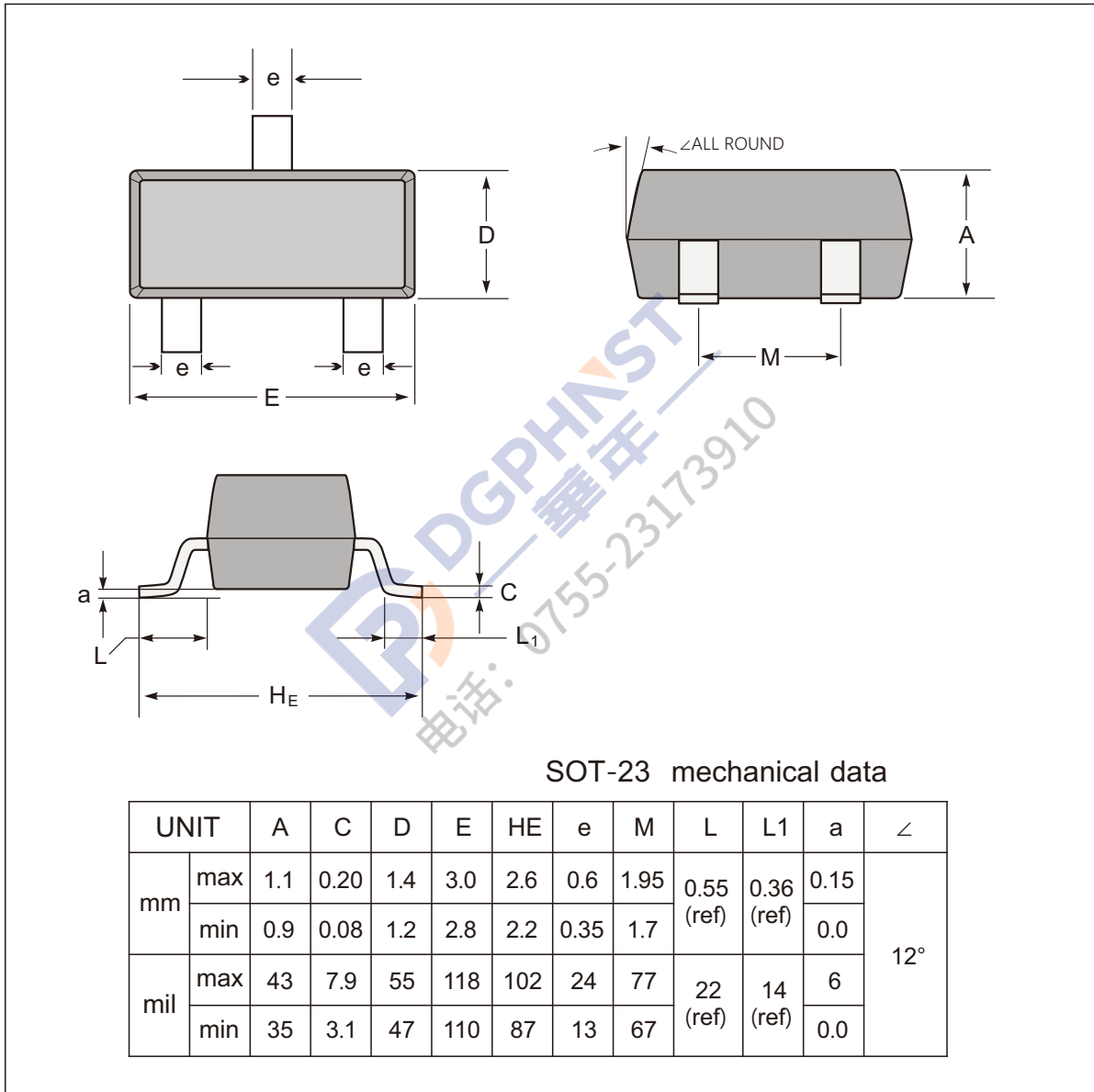

#### The recommended mounting pad size

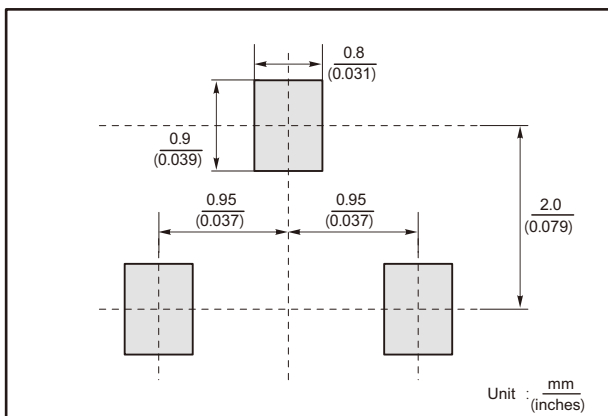

#### Marking

Type number	Marking code
2N7002AK	72AK



### Important Notice and Disclaimer

Jingdao Microelectronics reserves the right to make changes to this document and its products and specifications at any without notice.

Customers should obtain and confirm the latest product information and specifications before final, purchase or use.

Jingdao Microelectronics makes no warranty, representation or guarantee regarding the suitability of its products for any particular purpose, not does Jingdao Microelectronics assume any liability for application assistance or customer product design.

Jingdao Microelectronics does not warrant or accept any liability with products which are purchased or used for any unintended or unauthorized application.

No license is granted by implication or otherwise under any intellectual property rights of Jingdao Microelectronics.

Jingdao Microelectronics products are not authorized for use as critical components in life support devices or systems without express written approval of Jingdao Microelectronics.