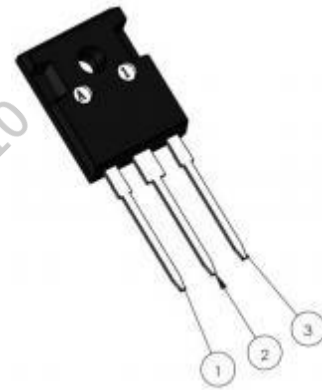

**Description**

Silicon Carbide (SiC) MOSFET use a completely new technology that provide superior switching performance and higher reliability compared to Silicon. In addition, the low ON resistance and compact chip size ensure low capacitance and gate charge. Consequently, system benefits include highest efficiency, faster operating frequency, increased power density, reduced EMI, and reduced system size.

**Features**

- High Speed Switching with Low Capacitances
- High Blocking Voltage with Low RDS(on)
- Easy to parallel and simple to drive
- ROHS Compliant, Halogen free

**Application**

- EV Charging
- DC/DC Converters
- Switch Mode Power Supplies
- UPS
- Solar PV inverters

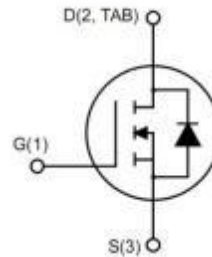
**Ordering Information**

Part Number	Marking	Package	Packaging
JX3S0040065M	JX3S0040065M	TO247-3	Tube

**Absolute Maximum Ratings(Tc=25°C)**

Symbol	Parameter	Value	Unit
V <sub>DS</sub>	Drain-Source Voltage	650	V
I <sub>D</sub>	Drain Current(continuous)at Tc=25°C	60	A
I <sub>D</sub>	Drain Current(continuous)at Tc=100°C	48	A
I <sub>DM</sub>	Drain Current (pulsed)	132	A
V <sub>GS</sub>	Gate-Source Voltage	-10/+25	V
P <sub>D</sub>	Power Dissipation Tc = 25°C	325	W
T <sub>J</sub> , T <sub>stg</sub>	Junction and Storage Temperature Range	-55 to +150	°C

**Electrical Characteristics(T<sub>J</sub> = 25°C unless otherwise specified)**
**Typical Performance-Static**

Symbol	Parameter	Test Conditions	Min.	Typ.	Max.	Unit
BV <sub>DS</sub>	Drain-source Breakdown Voltage	I <sub>D</sub> =250uA, V <sub>GS</sub> =0V	650			V
I <sub>DSS</sub>	Zero Gate Voltage Drain Current	V <sub>DS</sub> =650V, V <sub>GS</sub> =0V, T <sub>J</sub> =25°C		5	100	μA
I <sub>GSS</sub>	Gate-body Leakage Current	V <sub>DS</sub> =0V ; V <sub>GS</sub> = -10 to 20V		10	250	nA
V <sub>GS(th)</sub>	Gate Threshold Voltage	V <sub>DS</sub> = V <sub>GS</sub> , I <sub>D</sub> =10mA	2	3	4	V
V <sub>GSon</sub>	Recommended turn-on Voltage	Static		20		V
V <sub>GSoff</sub>	Recommended turn-off Voltage			-5		V
R <sub>DS(on)</sub>	Static Drain-source On Resistance	V <sub>GS</sub> =20V, I <sub>D</sub> =15A		38	49	mΩ
		V <sub>GS</sub> =20V, I <sub>D</sub> =15A T <sub>J</sub> =150°C		50		mΩ

**Typical Performance-Dynamic**

Symbol	Parameter	Test Conditions	Min.	Typ.	Max.	Unit
C <sub>iss</sub>	Input Capacitance	V <sub>DS</sub> =600V, f=1MHz, V <sub>AC</sub> =25mV		1866		pF
C <sub>oss</sub>	Output Capacitance			115		pF
C <sub>rss</sub>	Reverse Transfer Capacitance			9		pF
g <sub>fs</sub>	Transconductance	V <sub>DS</sub> =20V, I <sub>D</sub> =20A		13		S
E <sub>OSS</sub>	Coss Stored Energy	V <sub>DS</sub> =600V, f=1MHz		22		μJ
E <sub>ON</sub>	Turn-On Energy (Body Diode)	V <sub>DS</sub> =400V, V <sub>GS</sub> =-5/20V, I <sub>D</sub> =20A, L=100uH		220		μJ
E <sub>OFF</sub>	Turn-Off Energy (Body Diode)	T <sub>J</sub> =150°C		45		μJ
Q <sub>g</sub>	Total Gate Charge	V <sub>DS</sub> =400V, V <sub>GS</sub> =-5V/20V, I <sub>D</sub> =20A		81		nC
Q <sub>gs</sub>	Gate-source Charge			21		nC
Q <sub>gd</sub>	Gate-Drain Charge			21		nC
R <sub>G(int)</sub>	Internal Gate Resistance	f=1MHz, V <sub>AC</sub> =25mV		3.5		Ω
t <sub>d(on)</sub>	Turn-on Delay Time	V <sub>DS</sub> =400V, V <sub>GS</sub> =-5V/20V,		12		ns
t <sub>r</sub>	Rise Time	I <sub>D</sub> =20A, L=100 μH		35		ns
t <sub>d(off)</sub>	Turn-off Delay Time	R <sub>ext</sub> =2.5Ω		22		ns
t <sub>f</sub>	Fall Time			9		ns

**Typical Performance-Reverse Diode(T<sub>J</sub> = 25°C unless otherwise specified)**

Symbol	Parameter	Test Conditions	Min.	Typ.	Max.	Unit
V <sub>FSD</sub>	Forward Voltage	V <sub>GS</sub> =0V, I <sub>F</sub> =7.5A, T <sub>J</sub> =25°C		5.2	6	V
		V <sub>GS</sub> =0V, I <sub>F</sub> =7.5A, T <sub>J</sub> =150°C		4.8	6	V
I <sub>S</sub>	Continuous Diode Forward Current	V <sub>GS</sub> =0V, T <sub>C</sub> =25°C		30.5		A
t <sub>rr</sub>	Reverse Recovery Time	V <sub>GS</sub> =-5V, I <sub>F</sub> =15A,		36		nS
Q <sub>rr</sub>	Reverse Recovery Charge	V <sub>R</sub> =400V, T <sub>J</sub> =150°C		160		nC
I <sub>rrm</sub>	Peak Reverse Recovery Current	di/dt= 2400 A/μs		10.5		A

**Thermal Characteristics**

Symbol	Parameter	Value.	Unit
R <sub>θJC</sub>	Thermal Resistance, Junction-to-Case	0.38	°C/W
R <sub>θJA</sub>	Thermal Resistance, Junction-to-Ambient	40	°C/W

The values are based on the junction-to case thermal impedance which is measured with the device mounted to a large heat sink assuming maximum junction temperature of T<sub>J(max)</sub>=150°C

**Electrical Characteristics**

**Fig1. Output characteristics ( $T_J = 25\text{ }^\circ\text{C}$ )**

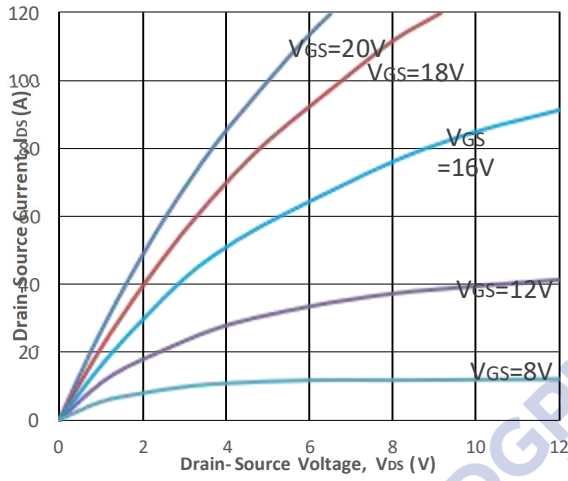

**Fig2. Output characteristics ( $T_J = 150\text{ }^\circ\text{C}$ )**

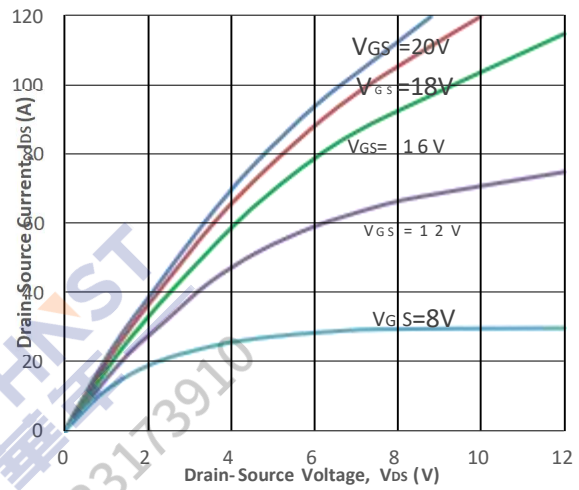

**Fig3. Normalized On-Resistance vs. Temperature**

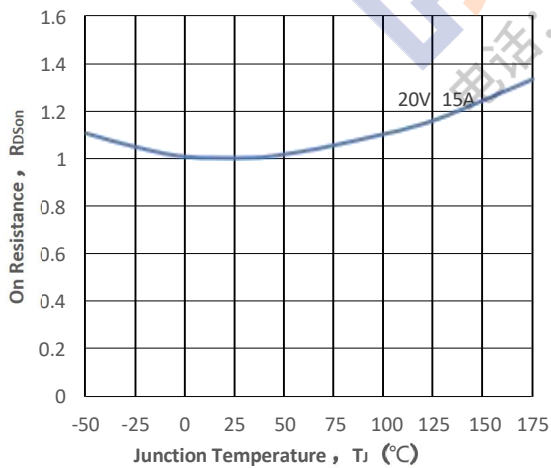

**Fig4. On-Resistance vs. Temperature**

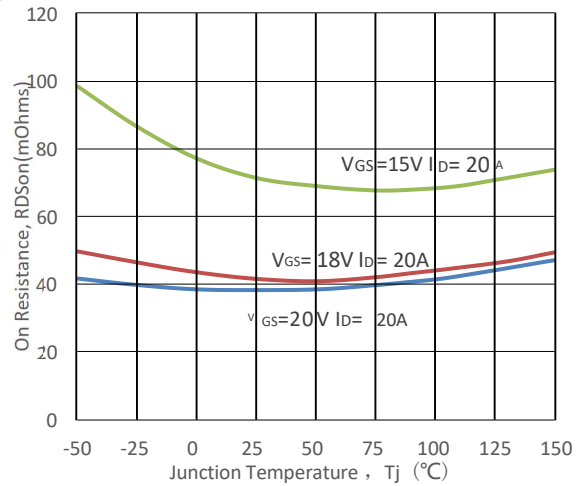

**Fig5. Transfer Characteristic**

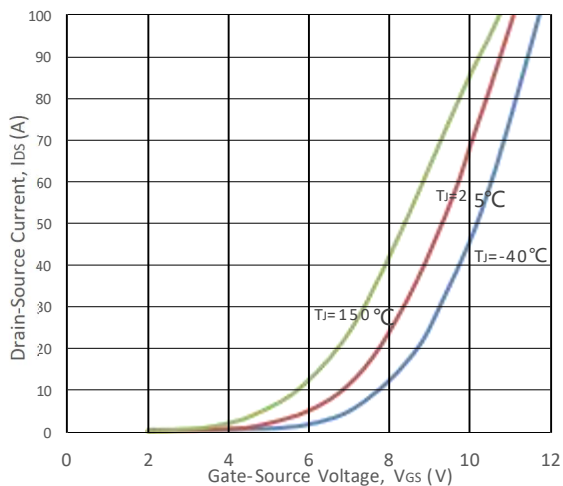

**Fig6. Body Diode Characteristic at  $25\text{ }^\circ\text{C}$**

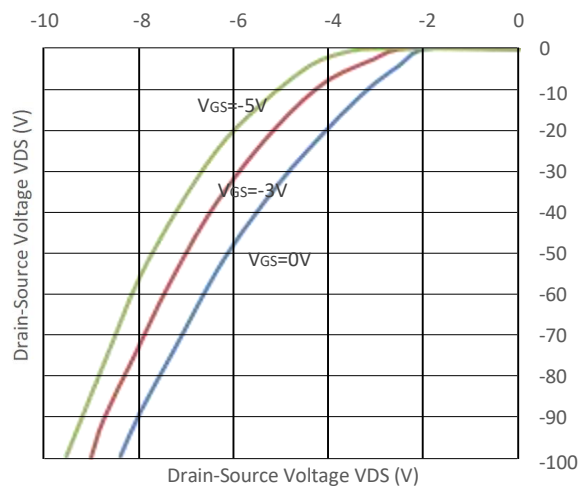

Fig7. Threshold Voltage vs. Temperature

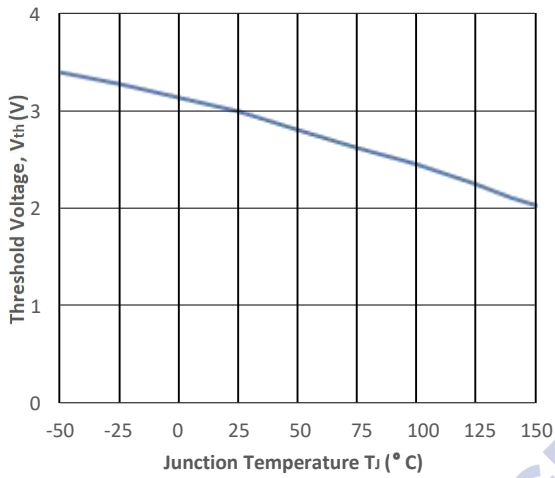

Fig8. Gate Charge Characteristics

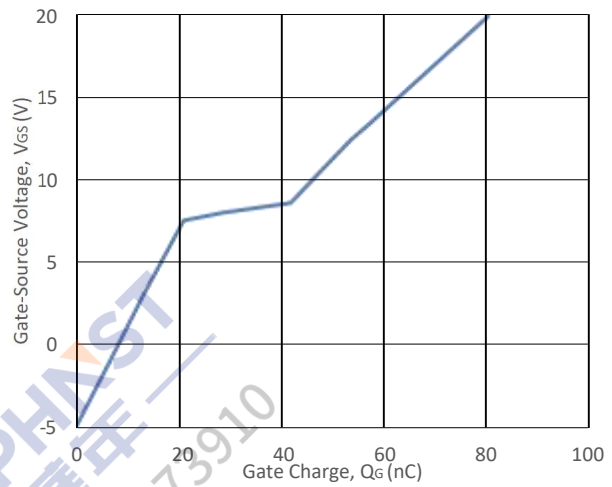

Fig9. 3rd Quadrant Characteristic at 25 °C

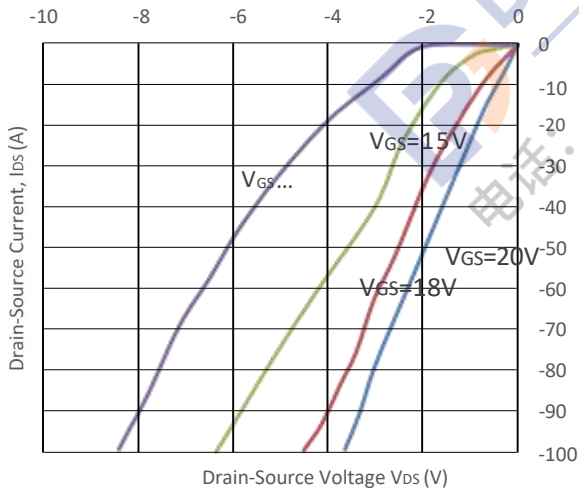

Fig10. Output Capacitor Stored Energy

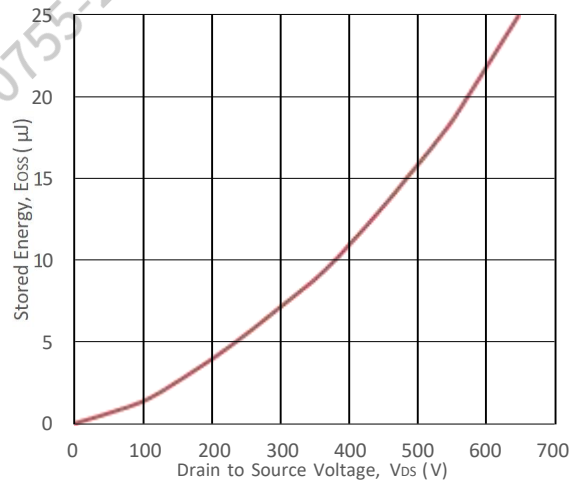

Fig11. Capacitances vs. Drain-Source

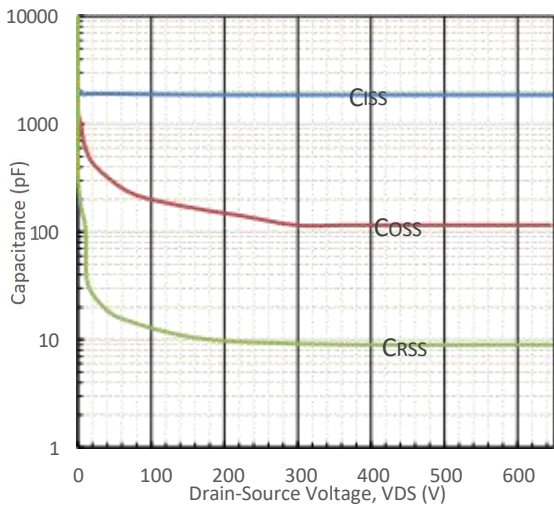

Fig12. Max Power Dissipation Derating Vs  $T_c$

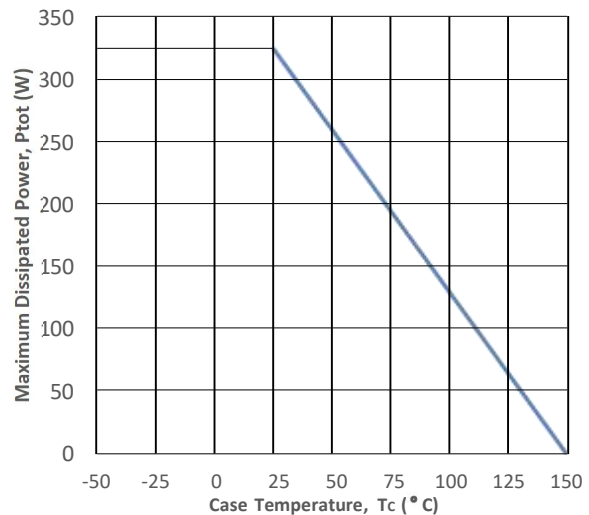

Fig13. Switching Energy vs. Drain Current

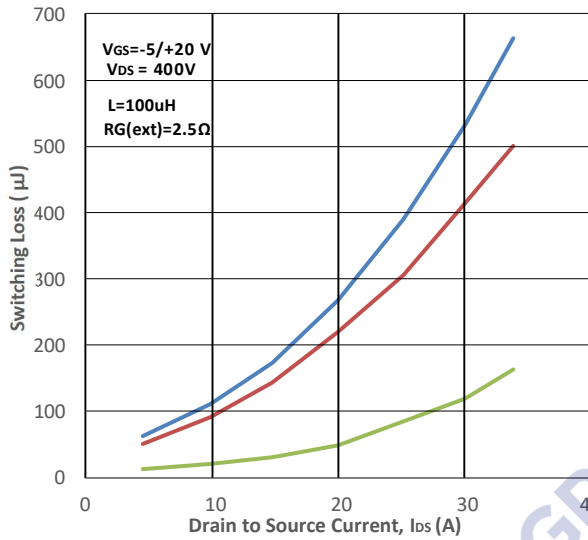

Fig14. Switching Energy vs.  $R_{G(ext)}$

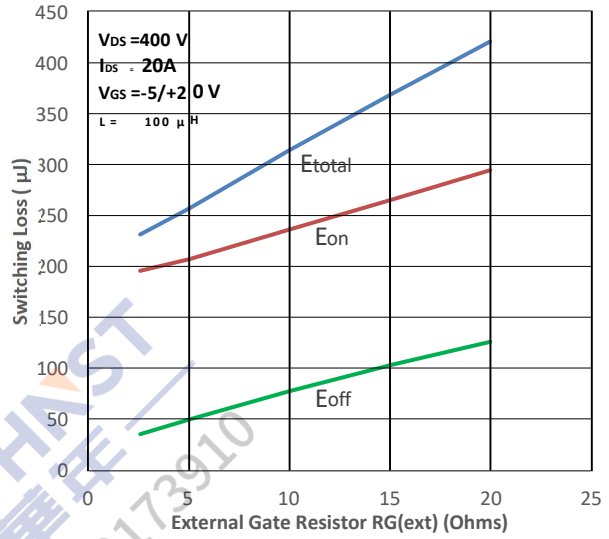

Fig15. Switching Energy vs. Temperature

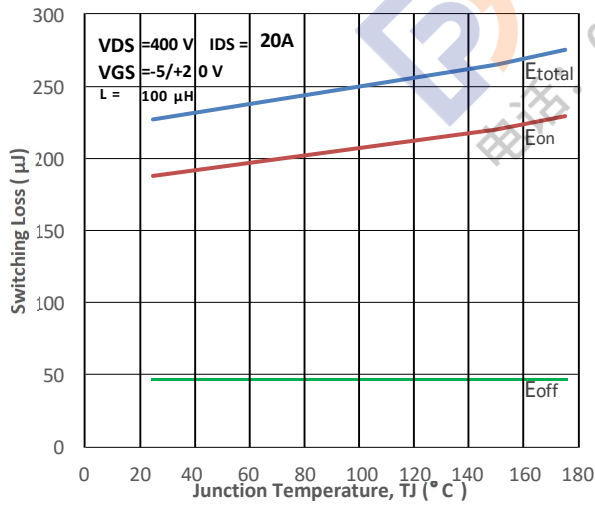

Fig16. Switching Times vs.  $R_{G(ext)}$

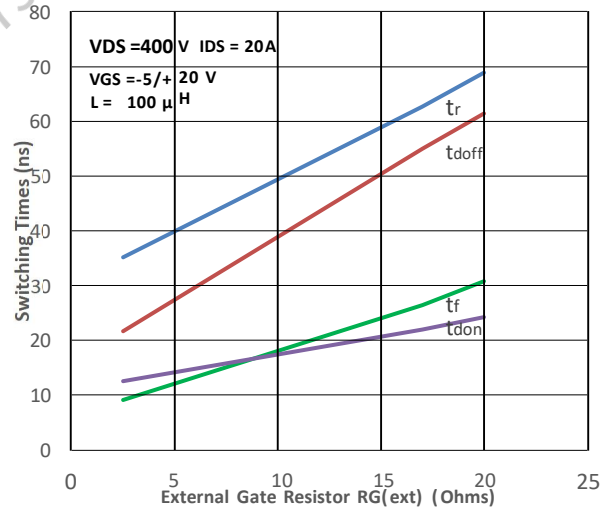

Fig17. Transient Thermal Impedance

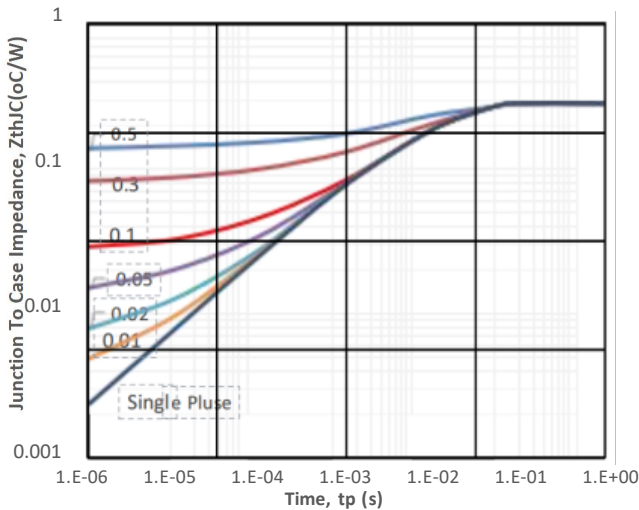
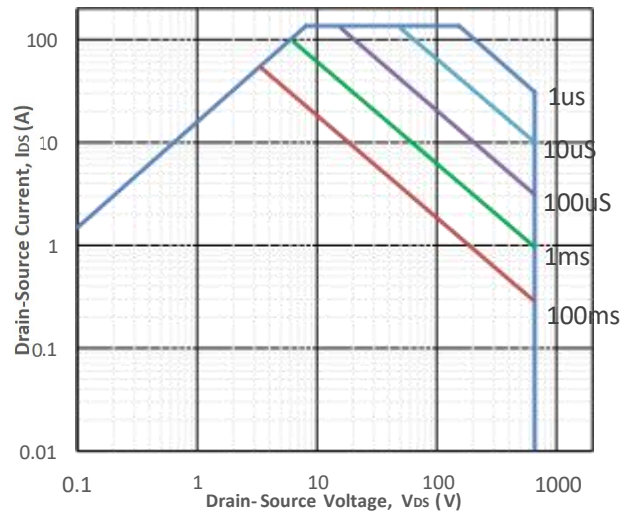
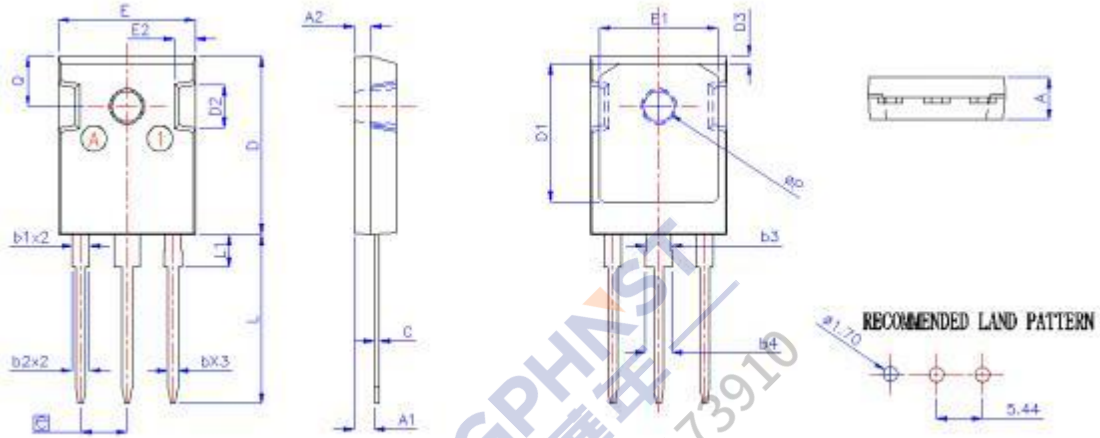

Fig18. Safe Operating Area



**Package Drawing:**

**Dimensions ( UNIT: mm)**

SYMBDLS	DIMENSIONS IN MILLIMETERS			DIMENSIONS IN INCHES		
	MIN	NOM	MAX	MIN	NOM	MAX
A	4.90	5.00	5.10	0.193	0.197	0.201
A1	2.31	2.42	2.52	0.091	0.095	0.099
A2	1.90	2.00	2.10	0.075	0.079	0.083
b	1.16	1.22	1.27	0.046	0.048	0.050
b1	1.96	2.02	2.07	0.079	0.080	0.081
b2	2.03	2.07	2.10	0.080	0.0815	0.083
b3	2.96	3.02	3.07	0.117	0.119	0.121
b4	3.03	3.07	3.1	0.119	0.120	0.122
C	0.59	0.62	0.66	0.023	0.024	0.026
D	20.90	21.00	21.10	0.823	0.827	0.831
D1	15.96	16.26	16.56	0.628	0.640	0.652
D2	4.3			4.3		
D3	0.8	0.95	1.1	0.031	0.037	0.043
e	5.44 BSC			0.214 BSC		
E	15.95	16.15	16.35	0.628	0.636	0.644
E1	13.82	14.02	14.26	0.544	0.552	0.561
E2	4.3			0.169		
L	19.72	19.92	20.12	0.776	0.784	0.792
L1	---	---	3.86	---	---	0.152
Q	5.95 BSC			0.234BSC		
ØP	3.55	3.60	3.70	0.140	0.142	0.146