

LBC846BLT1G

S-LBC846BLT1G

General Purpose Transistors NPN Silicon

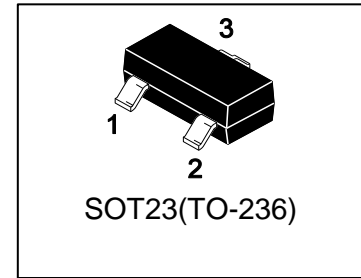

1. FEATURES

- Moisture Sensitivity Level: 1
- ESD Rating – Human Body Model: >4000 V
– Machine Model: >400 V
- We declare that the material of product compliance with RoHS requirements and Halogen Free.
- S- prefix for automotive and other applications requiring unique site and control change requirements; AEC-Q101 qualified and PPAP capable.

2. DEVICE MARKING AND ORDERING INFORMATION

Device	Marking	Shipping
LBC846BLT1G	1B	3000/Tape&Reel
LBC846BLT3G	1B	10000/Tape&Reel

3. MAXIMUM RATINGS(Ta = 25°C)

Parameter	Symbol	Limits	Unit
Collector–Emitter Voltage	VCEO	65	V
Collector–Base Voltage	VCBO	80	V
Emitter–Base Voltage	VEBO	6	V
Collector Current — Continuous	IC	100	mA

4. THERMAL CHARACTERISTICS

Parameter	Symbol	Limits	Unit
Total Device Dissipation, FR-5 Board (Note 1) @ TA = 25°C Derate above 25°C	PD	225 1.8	mW mW/°C
Thermal Resistance, Junction–to–Ambient(Note 1)	RθJA	556	°C/W
Junction and Storage temperature	TJ, Tstg	-55~+150	°C

1. FR-5 = 1.0×0.75×0.062 in.

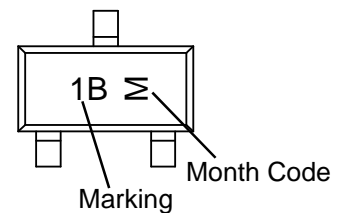
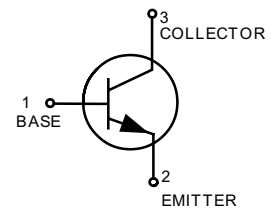

5. ELECTRICAL CHARACTERISTICS (Ta= 25°C)

OFF CHARACTERISTICS

Characteristic	Symbol	Min.	Typ.	Max.	Unit
Collector–Emitter Breakdown Voltage (IC = 10 mA)	VBR(CEO)	65	-	-	V
Collector–Emitter Breakdown Voltage (IC = 10 μA, VEB = 0)	VBR(CES)	80	-	-	V
Collector–Base Breakdown Voltage (IC = 10 μA)	VBR(CBO)	80	-	-	V
Emitter–Base Breakdown Voltage (IE = 1.0 μA)	VBR(EBO)	6	-	-	V
Collector Cutoff Current (VCB = 30 V)	ICBO	-	-	15	nA
(VCB = 30 V, TA = 150°C)		-	-	5	μA

ON CHARACTERISTICS

DC Current Gain (IC = 2.0 mA, VCE = 5.0 V)	HFE	200	290	450	
Collector–Emitter Saturation Voltage (IC = 10 mA, IB = 0.5 mA)	VCE(sat)	-	-	0.25	V
(IC = 100 mA, IB = 5.0 mA)		-	-	0.6	
Base–Emitter Saturation Voltage (IC = 10 mA, IB = 0.5 mA)	VBE(sat)	-	0.7	-	V
(IC = 100 mA, IB = 5.0 mA)		-	0.9	-	
Base–Emitter Voltage (IC = 2.0 mA, VCE = 5.0 V)	VBE(on)	580	660	700	mV
(IC = 10 mA, VCE = 5.0 V)		-	-	770	

SMALL–SIGNAL CHARACTERISTICS

Current–Gain — Bandwidth Product (IC = 10 mA, VCE = 5.0 V, f = 100 MHz)	fT	100	-	-	MHz
Output Capacitance (VCB = 10 V, f = 1.0 MHz)	Cobo	-	-	4.5	pF
Noise Figure (IC = 0.2 mA, VCE = 5.0 V, RS = 2.0 kΩ f = 1.0 kHz, BW = 200 Hz)	NF	-	-	10	dB

6.ELECTRICAL CHARACTERISTICS CURVES

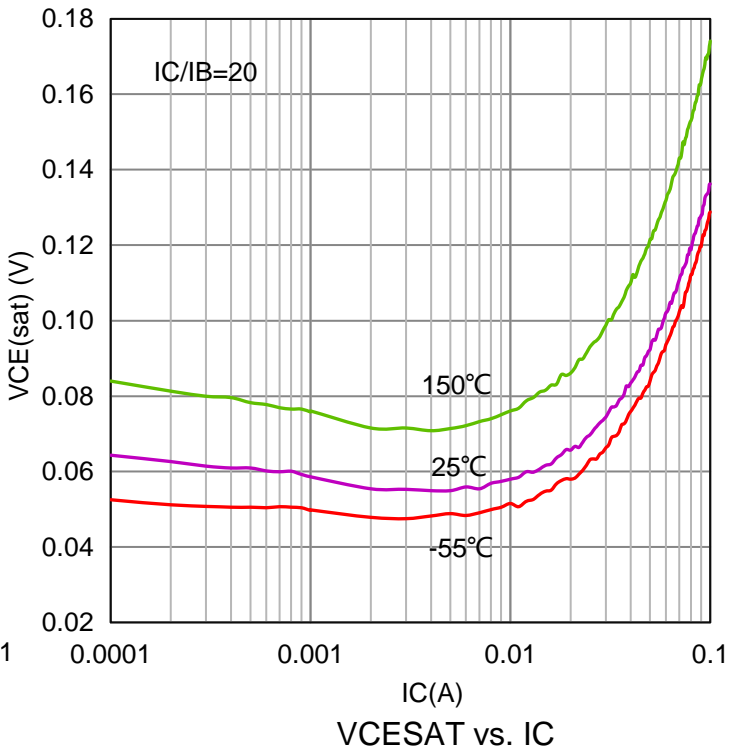
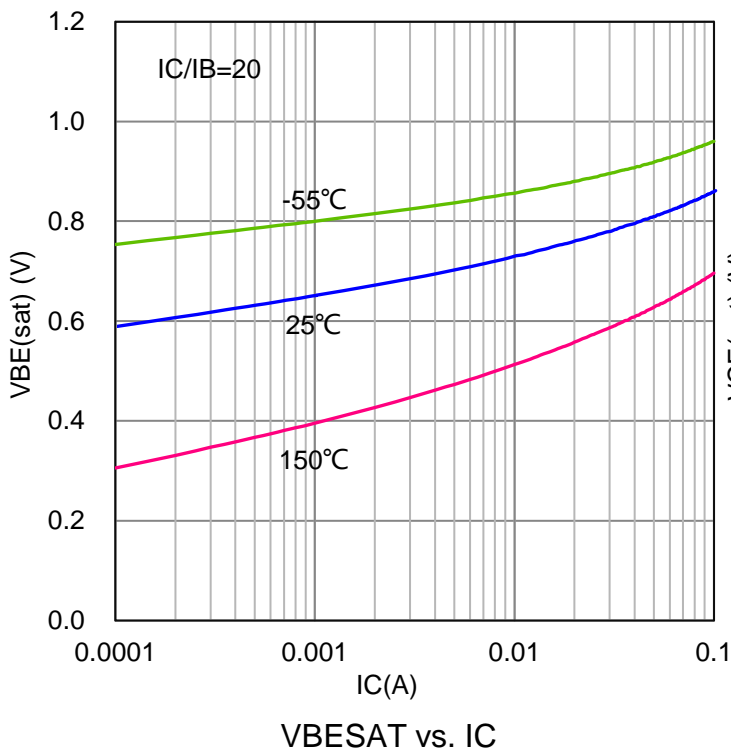
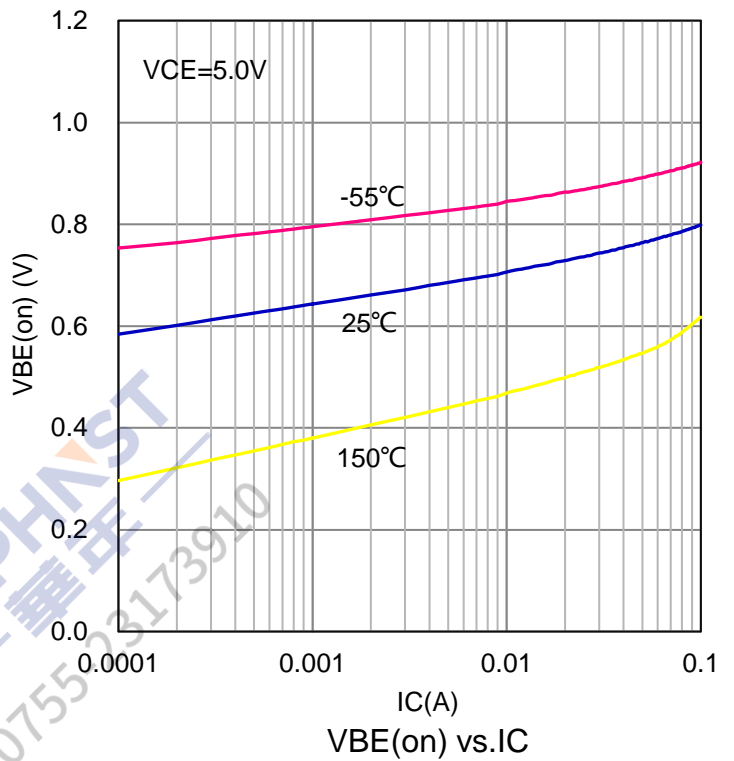
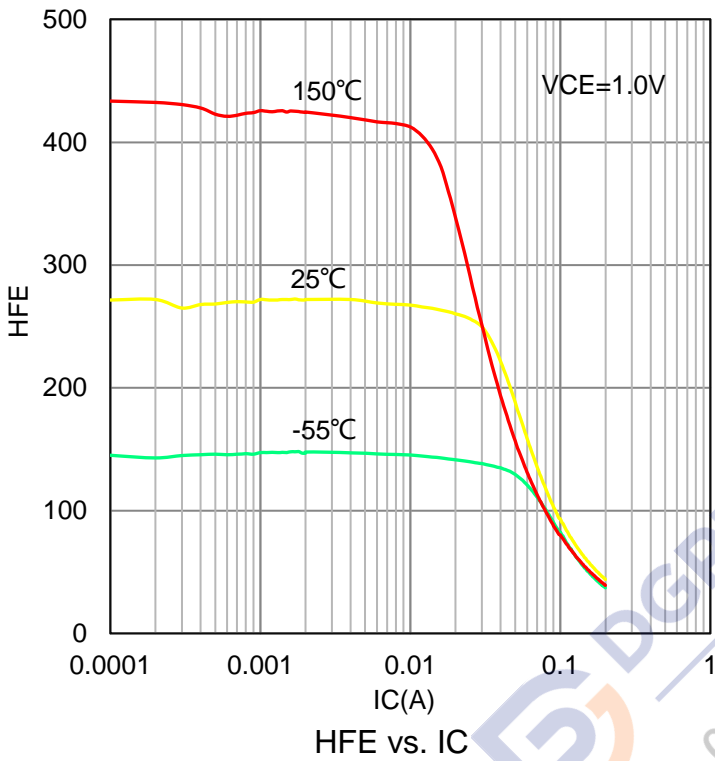

6.ELECTRICAL CHARACTERISTICS CURVES(Con.)

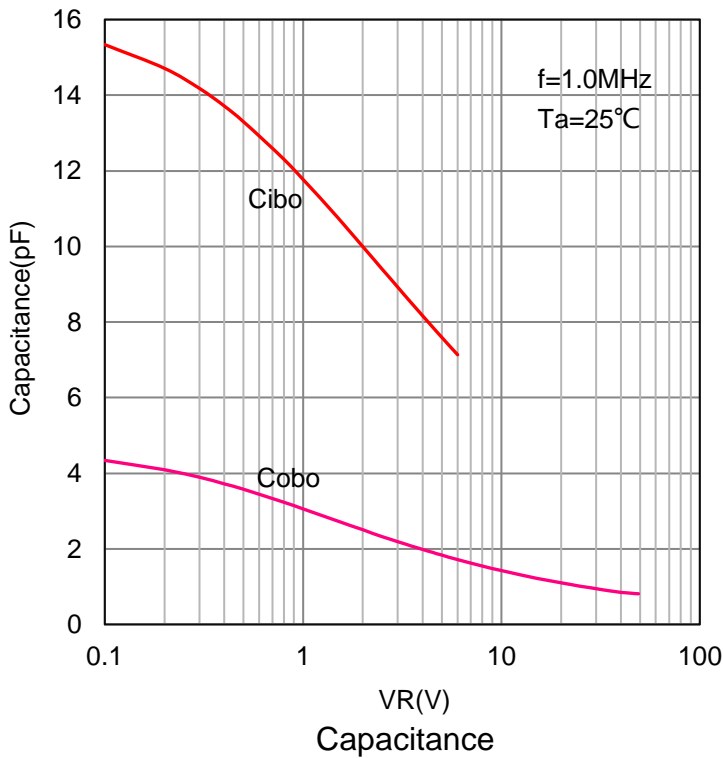
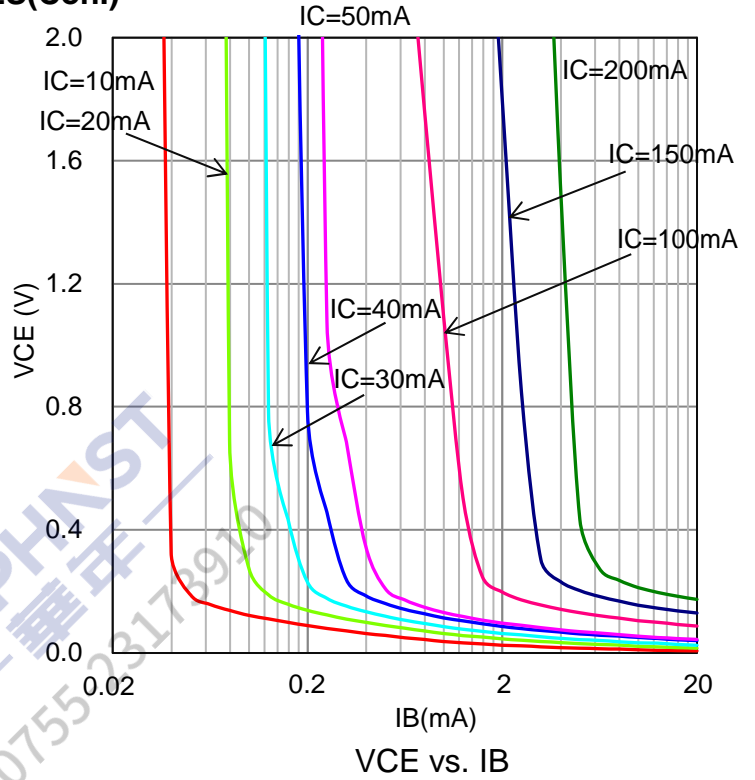
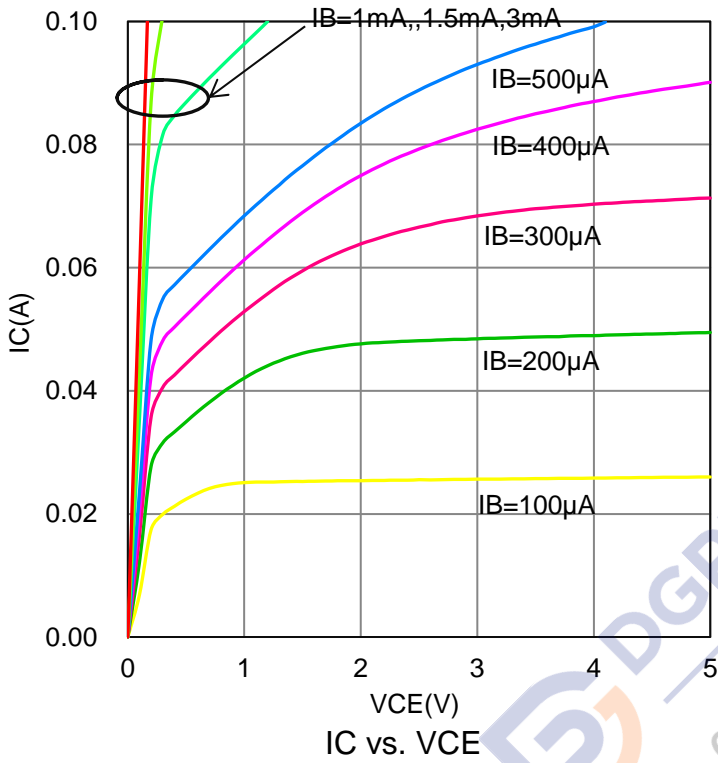

7. OUTLINE AND DIMENSIONS

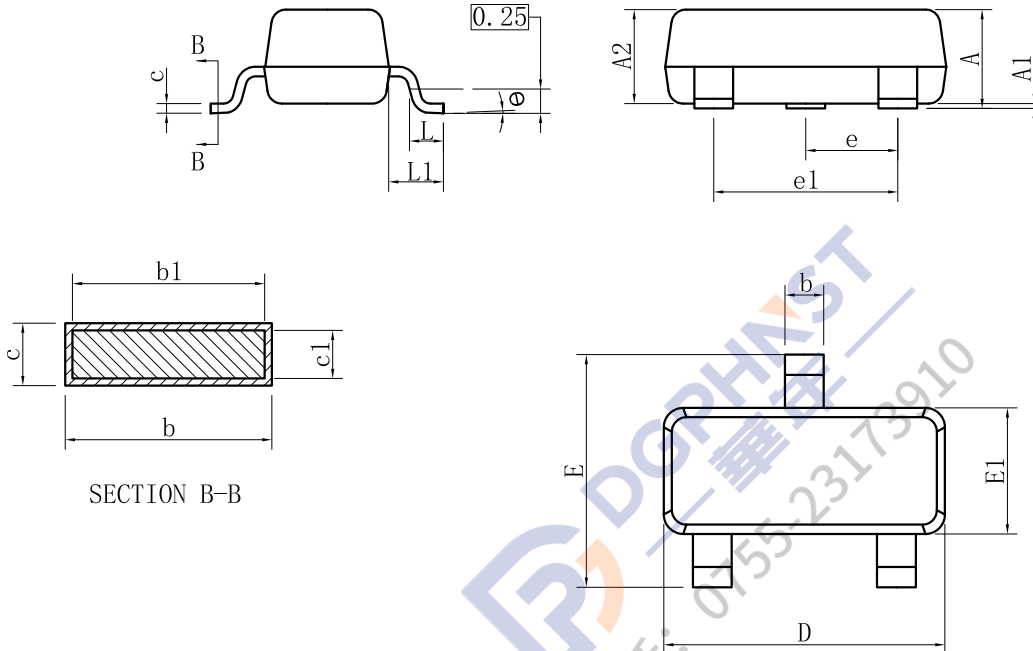

SOT23			
DIM	MIN	NOR	MAX
A	0.89	-	1.12
A1	0.01	-	0.10
A2	0.88	0.95	1.02
b	0.30	-	0.50
b1	0.30	0.40	0.45
c	0.08	-	0.20
c1	0.08	0.10	0.16
D	2.80	2.90	3.04
E	2.10	-	2.64
E1	1.20	1.30	1.40
e	0.95BSC		
e1	1.90BSC		
L	0.40	0.46	0.60
L1	0.54REF		
θ	0°	-	8°
All Dimensions in mm			

GENERAL NOTES

1. Top package surface finish Ra0.4±0.2um
2. Bottom package surface finish Ra0.7±0.2um
3. Side package surface finish Ra0.4±0.2um

8. SOLDERING FOOTPRINT

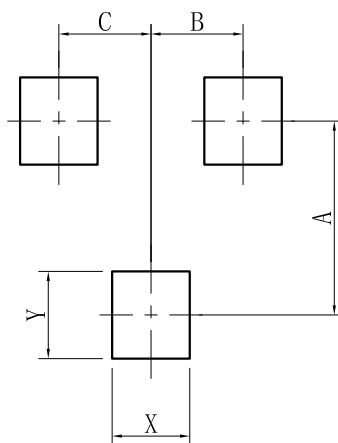

SOT-23	
DIM	(mm)
X	0.80
Y	0.90
A	2.00
B	0.95
C	0.95

DISCLAIMER

- Curve guarantee in the specification. The curve of test items with electric parameter is used as quality guarantee. The curve of test items without electric parameter is used as reference only.
- Before you use our Products for new Project, you are requested to carefully read this document and fully understand its contents. LRC shall not be in any way responsible or liable for failure, malfunction or accident arising from the use of any LRC's Products against warning, caution or note contained in this document.
- All information contained in this document is current as of the issuing date and subject to change without any prior notice. Before purchasing or using LRC's Products, please confirm the latest information with a LRC sales representative.