

APPROVAL SHEET

承认书

Customer 客户	深圳市顺海科技有限公司	
Product Name 品名	金属化聚丙烯膜介质直流固定电容器 Fixed metallized polypropylene film dielectric d.c capacitors Type MPF	
Customer P/N 客户料号 EG P/N EG 代码	Customer P/N 客户料号	EG P/N EG 代码
		MPF104K630D10L250(60)
Date 日期	2025-03-15	

(MANUFACTURER APPROVAL) 供应商承认栏			(CUSTOMER APPROVAL) 客户承认栏		
Prepared 承办	Checked 审核	Approved 批准	Prepared 承办	Checked 审核	Approved 批准
赵红	赵红	魏龙			

MANUFACTURER: EASY-GATHER ELECTRONIC CO.,LTD

供应商: 东莞市易利嘉电子有限公司



Building 3, 9 Yinhu Road, Sangyuan, Dongcheng District, Dongguan, Guangdong, China.

Post code:523119

地址: 广东省东莞市东城街道桑园银湖路9号3号楼

邮编:523119

TEL: 0769-86219238 86219239 FAX: 0769-86219638

HTTP://WWW.EASYGATHER.COM

E-MAIL:SALES@EASYGATHER.COM



东莞市易利嘉电子有限公司

电容器（筒式）规格书

MPF104K630D10L250(60)

推荐

目前生产

一般用

105

波峰

RoHS

REACH

H F

EG-RD4-021-19-0

初始日期 2025-03-15

更新日期 2025-03-15

外形及标志

宽度尺寸 W	13.0mm Max
高度尺寸 H	12.5mm Max
厚度尺寸 T	6.5mm Max
引线间距 P	10.0±1.0 mm
引线直径 d	0.60±0.06 mm
引线长度 L	20.0Min mm

参考信息

包装	散件或编带	最小包装数量
	散件	500PCS
环保法规与指令符合情况	法规或指令	法规或指令所限制有害物质
	欧盟 2005/84/EC	邻苯二甲酸盐(18P)
	GS 认证 PAHS 要求	多环芳香烃(PAHS)

电气性能

气候类别	40/105/21
标称电容量	0.1 μ F
额定电压	630VDC
标称电容量误差	±10%
耐电压	1008VDC
介质损耗	0.1% Max
绝缘电阻	$\geq 100000M \Omega$
工作温度范围	-40 $^{\circ}$ C ~ +105 $^{\circ}$ C

1.5 Electrical Specifications 电气特性

Item 项目	Specification 标准要求					
Climatic Category 气候类别	40/105/21					
Operating Temperature 工作温度	-40℃~+105℃ (+85℃ to+105℃: decreasing factor 1.25% per °C for U _R)					
Capacitance Range 容量范围	0.0047μF~4.7μF					
Capacitance Tolerance 容量偏差	J: ±5%、K: ±10%					
Rated AC Voltage(IEC60384-14) 额定交流电压	250Vdc (160Vac)、400V/450Vdc (200Vac) 630Vdc (220Vac)、630Vdc (310Vac)					
Dissipation Factor 介质损耗	≤0.1%(1KHz at 20~25℃)					
Insulation Resistance 绝缘电阻	class I standard I 级标准	≥100000MΩ for C _R ≤0.33μF ; ≥30000S for C _R >0.33μF (Measured at 100±10VDC/60s/20~25℃)				
	class II standard II 级标准	≥25000MΩ for C _R ≤0.33μF ; ≥7500S for C _R >0.33μF (Measured at 100±10VDC/60s/20~25℃)				
Withstand Voltage Between Terminals 端子间耐压	class I standard I 级标准	1.6U _R (5s)				
	class II standard II 级标准	1.4U _R (5s)				
Withstand Voltage Between Terminals and Case 端子与壳体间耐压	2U _R					
If the working voltage(U) is lower than the rated voltage(U _R),the capacitor can be worked at a higher dv/dt,In this case,the maximum alloweb dv/dt is obtain by multiplying the right value with U _R /U. 最大脉冲爬升速率 Maximum Pulse rise Time(dv/dt): 若实际工作电压 U 比额定电压 U _R 低, 电容器可工作在更高的 dv/dt 场合, 这样 dv/dt 允许值应为右表值乘以 U _R /U。	U _R (V)	dv/dt(V/us)				
		P=7.5	P=10.0	P=15.0	P=22.5	P=27.5
	250	660	560	310	130	110
	400/450	900	780	600	300	180
630	1500	1200	900	400	220	

1.6 电气特性图:

■ 最大可允许电压 (Vr.m.s) ---频率特性曲线

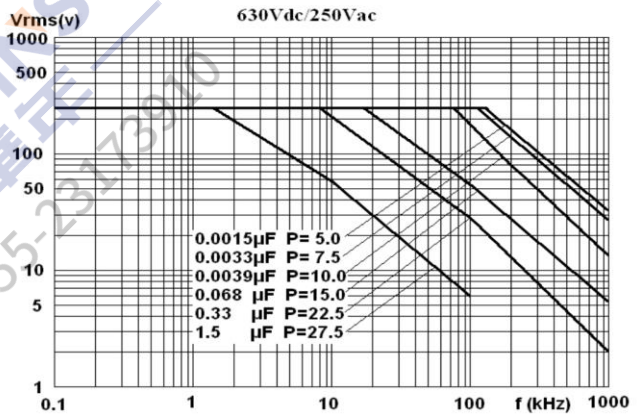
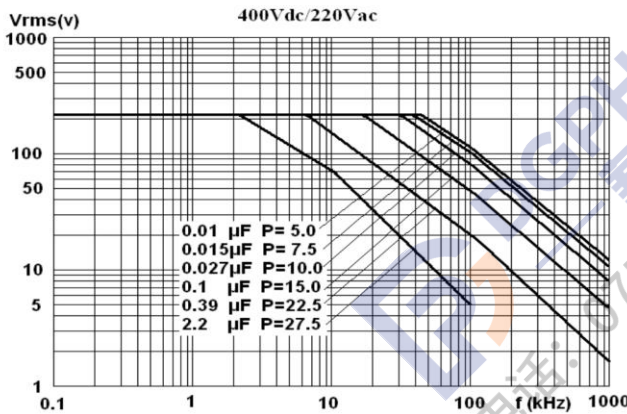
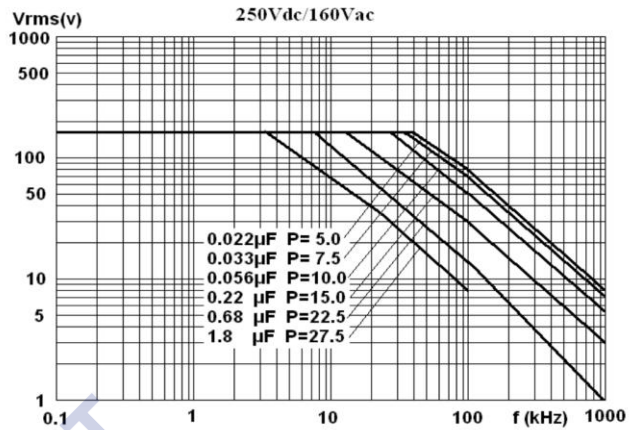
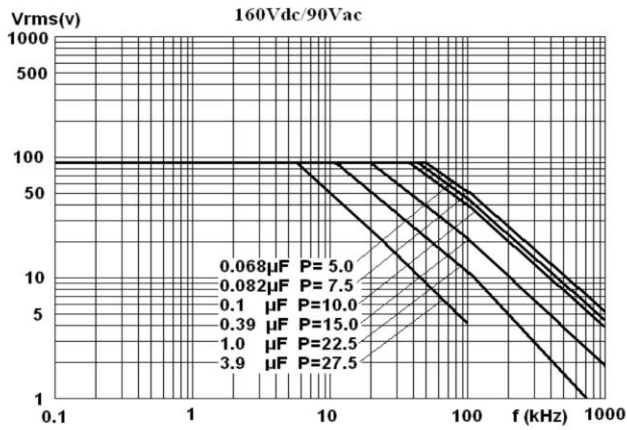

■ 最大可允许电流 (Ir.m.s) ---频率特性曲线

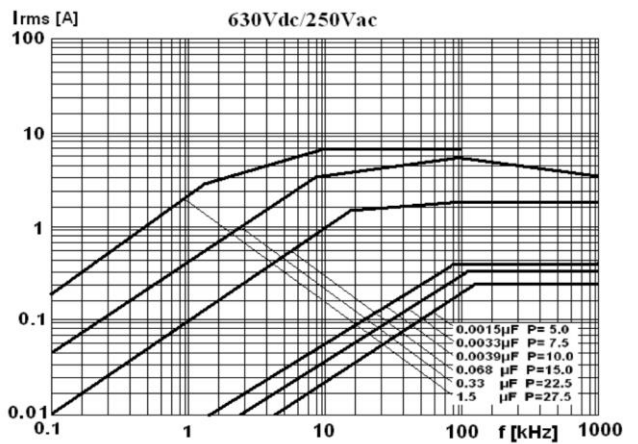
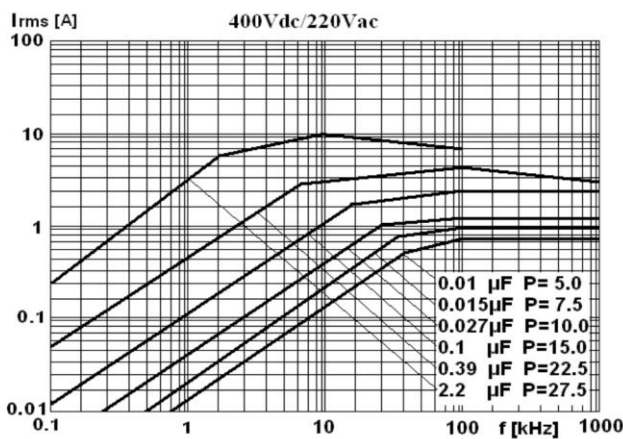
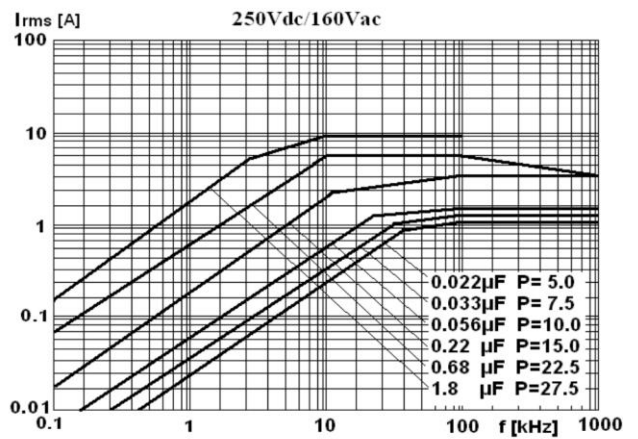
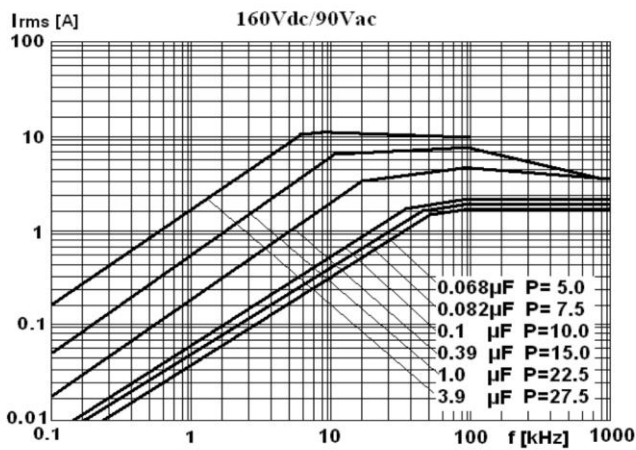

2 EG Part number system 易利嘉产品代码

MPF	472	K	630	D	05	K	20	0	(80)
1	2	3	4	5	6	7	8	9	10 11

1 Product Categories 产品类别代码:

Fixed metallized polypropylene film dielectric d.c capacitors
MPF:CBB21 金属化聚丙烯膜介质直流固定电容器

2 Capacitance Code 电容量代码:

The first 2 digits indicate significant figures, and the third digit specifies the number of zero to follow.
前两位数为电容的实际数字,最后一位为倍乘数。

0= $\times 1$ 1= $\times 10$ 2= $\times 100$
3= $\times 1000$ 4= $\times 10000$ 9= $\times 0.1$

This gives the capacitance in picofarad. 容量值单位为皮法 (pF)。

102 = 10×10^2 pF = 1,000 pF = 1.0 nF = 0.001 μ F 105 = 10×10^5 pF = 1,000,000 pF = 1000 nF = 1 μ F

3 Capacitance Tolerance 电容量允许偏差:

J= $\pm 5\%$ K= $\pm 10\%$

4 Rated Voltage 额定电压:

250=250Vdc (63Vac)、400=400V/450Vdc (200Vac)、630=630Vdc (220Vac、310Vac)

5 Voltage Type 电压类别:

D=direct voltage 直流电压

6 Lead Space 引线间距(mm):

05=5.0 07=7.5 10=10.0 15=15.0 20=20.0 27=27.5

7 Lead Style 线型形状:

L/M-type 直线 K-type 直线外弯 Y-type 直脚内弯 J-type 单内弯、单外弯

8 Lead Length 引线长度(mm):

35=3.5 \pm 0.5 40=4.0 \pm 0.5 50=5.0 \pm 0.5 80=8.0 \pm 1.0 10=10.0 \pm 1.0 25=20.0Min T=12.7mm
Feeding hole pitch 孔距编带 S=15.0mm Feeding hole pitch 孔距编带

9 RoHS Symbol 环保标识:

0: Environmentally friendly products (in compliance with RoHS, Reach, and do not contain PAH or phthalates).

环保产品 (符合RoHS、Reach、不含多环芳烃、不含邻苯二甲酸盐)

1: Non environmentally friendly 非环保

2: In addition to being compliant with the aforementioned environmentally friendly criteria "0", it should also show that the amount of halogens contained in the product meets the criteria.

除符合上述"0"代表的环保要求外, 还符合不含卤素。

10~12 Management Code 内部管理码

3Marking 标志 (示例 1) 脚距 P < 10mm

Marking Item 产品标志		Example 范例
Manufacturer Marking 厂商标志		
Capacitance, Tolerance 容量与精度	472K	
Rated Voltage 标称电压	630V	

标志 (示例 2) 脚距 P > 15mm

Marking Item 产品标志		Example 范例
Manufacturer Marking 厂商标志		
Type Designation 种类标志	CBB21	
Capacitance, Tolerance 容量与精度	105K	
Rated Voltage 标称电压	400V	

4Packing in bulk 包装说明

4.1(Outside packing box)外包装箱尺寸

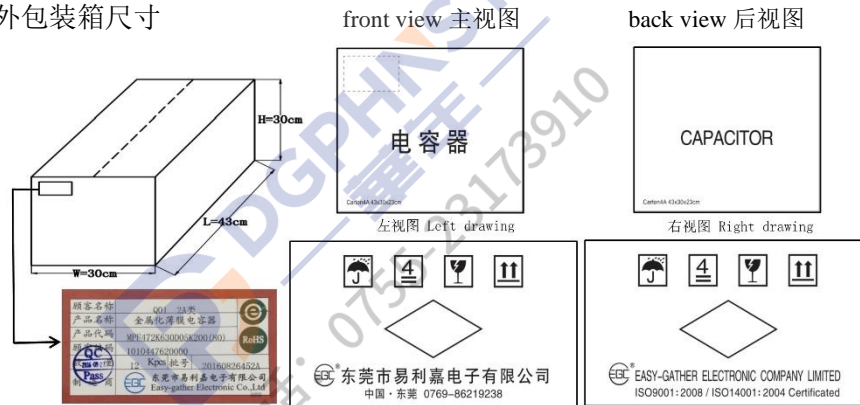

4.2 (Inner packing box)内包装箱尺寸

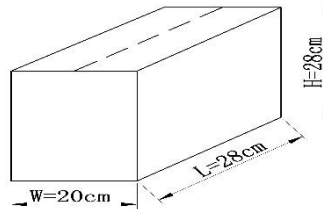

4.3 Bag mark photo 内袋标签图示:

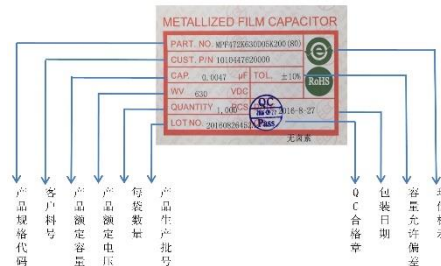

4.4Package picture 内袋包装图示:



5 Regulation in usage 使用规则

5.1 Operating and storage environmen 使用和储存环境

The insulating coating of capacitors does not form a perfect seal; therefore, do not use or store capacitors in a corrosive atmosphere, especially where chloride gas, sulfide gas, acid, alkali, salt or the like are present. And avoid exposure to moisture. Before cleaning, bonding, or molding this product, verify that these processes do not affect product quality by testing the performance of a cleaned, bonded or molded product in the intended equipment. Store the capacitors where the temperature and relative humidity do not exceed -10 to 40°C and 15 to 75%.

Being exposed in air for too long may result in attenuation of leads' welding performance.

Please use capacitors within 12 months and the date on packaging label should prevail. If overdue, the capacitors should be confirmed the performance before use.

电容器的绝缘涂层不可能完全密封。因此，不要在下列大气环境下使用或者储存电容器：含有腐蚀性气体、特别是放置有含氯气体、含硫气体的地方、放置有酸、碱、盐等物质的地方。也要尽量避免将电容器暴露在潮湿的空气中。在清洗、焊接或者成型产品前要确认这些过程不会影响产品的品质，这种确认可以通过使用特定装备来测试清洗过、焊接过或者成型过的产品来核实。电容器储存温度为-10°C~40°C，相对湿度为15%~75%。

长时间暴露在空气中会导致引线焊接性能衰减。

请在12个月内使用电容器(以包装标签日期为准)。如超期，应进行性能确认再使用。

Mini size capacitors can fulfill normal purposed uses, while the standard size product has a better performance, by providing a longer valid period. Furthermore, when using in an alternating current, a standard size product is recommended. For the case of a high-frequency and high-voltage circuit, full consideration should be given to the technical situation of 1A rated current.

小型化电容器满足一般用途，标准品电容器则有更好的性能表现，可以满足更高（长寿命）的使用要求。用于交流电路时，建议使用标准品电容。如果是高频、高压电路应充分考虑电容器的额定电流为1A这一技术限制。

5.2 Vibration and impact 振动和撞击

Do not expose a capacitor or its leads to excessive shock or vibration during use.

使用时，避免电容器及电容器引线受到过多的撞击或者振动。

5.3 Soldering 焊接

(1) 手动焊接：

最高温度 350°C，时间 3S

(1) Manual soldering:

Maximum temperature 350°C, time 3S

(2) 波峰焊工艺过程中有较多因素对薄膜电容器受热有影响，如：预热温度、预热时间、锡炉温度、过锡炉时间、其它热源影响等。

典型焊接曲线如下：

(2) There are many factors that affect the heating of film capacitors during the wave soldering process, such as: preheating temperature, preheating time, tin furnace temperature, tin furnace passing time, the influence of other heat sources, etc.

Typical soldering curves are as follows:

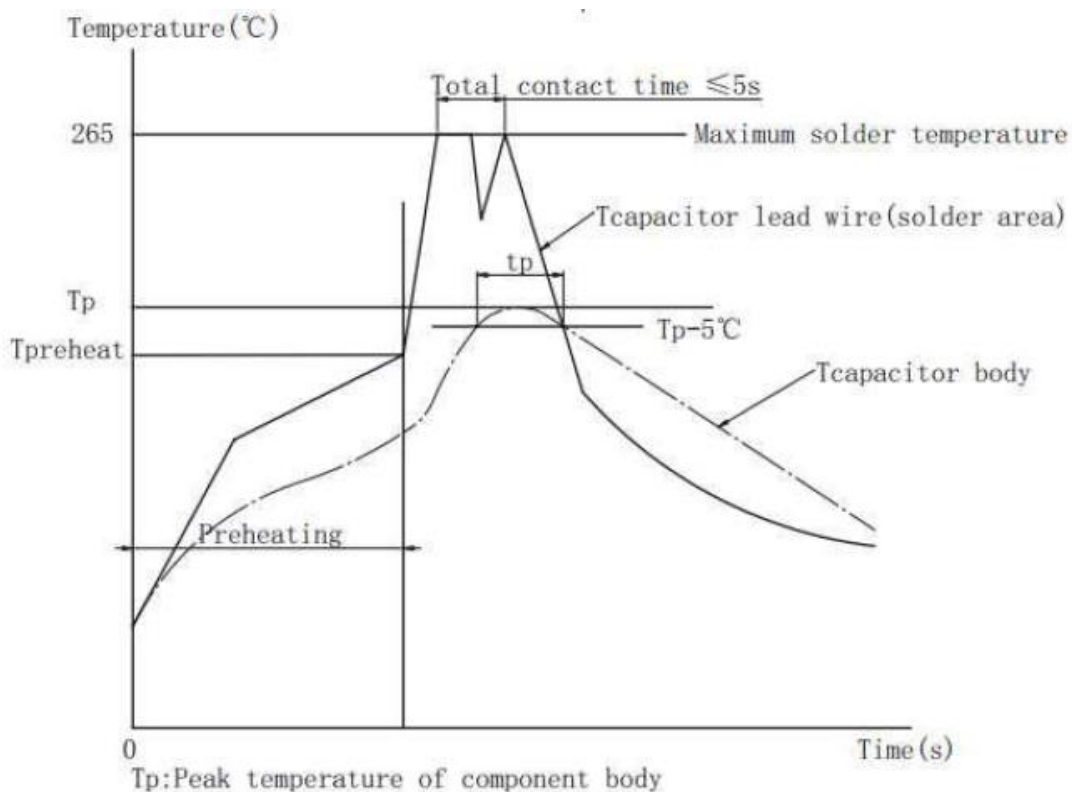

- (3) 因为过热有可能会损坏电容器，我们建议关注电容器最高温度及耐热时间，用热电偶检测电容本体最高温度 TP（测量位置参考下图）
- (3) Because overheating may damage the capacitor, we recommend paying attention to the maximum temperature and heat resistance time of the capacitor, and using a thermocouple to detect the maximum temperature TP of the capacitor body (refer to the picture below for the measurement location)

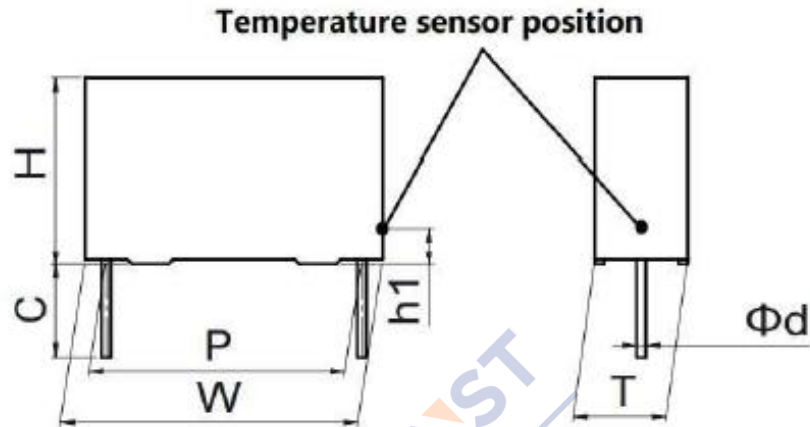

测量点位置 Temperature sensor position (Tcapacitor body)	电容器引线侧的外壳表面，电容距 PCB 板高度：h1=2-3mm 的位置 The capacitor body surface of lead side, capacitor height position from PCB: h1=2-3mm		
焊接过程电容本体最高耐热温度 Maximum capacitor body temperature TP (°C)	OPP film P≤15mm 115	OPP film P>15mm 120	PET film 125
焊接过程电容引脚最高耐热温度 Maximum capacitor lead wire temperature TP (°C)	265	265	265
焊接过程电容本体最长耐热时间 Maximum capacitor body heating time Tp=TP-5°C	30s		

备注：如果需要焊接两次，第二焊接必须等到电容器恢复到常温。

Note: If two soldering are required, the second soldering must be Wait until the capacitor returns to normal temperature.

5.4 耐压试验被试验样品及试验环境应符合：

Temperature 环境温度: 小于 35 °C

Relative humidity 相对湿度: 25~75%

试验样品：应在相对湿度不大于 75%条件下放置 24 小时以上。

6 Characteristics and test conditions 电气特性和测试条件

Test condition: Unless otherwise specified, the standard range of atmospheric

Conditions for marking measurements and test is as follows Ambient

测试条件:除非另外说明，则在标准大气范围内测试，条件如下：

Temperature 环境温度: 15~35 °C,

Relative humidity 相对湿度: 25~75%.

If there may be any doubt on the results, measurements shall be made within the Following limits.

如对测试结果有任何疑问，则按以下限制测试：

Ambient temperature 环境温度:20±2°C , Relative humidity 相对湿度: 60~70%.

No	Item 项目		Test method 试验方法	Specification 技术参数		
1	Appearance 外观		The appearance shall be inspected by naked eyes. 用肉眼检查外观	No marked defect on appearance 外观无显著缺陷		
2	Dimensions 尺寸		The dimensions shall be measured with slide calipers 用游标卡尺测量尺寸	Dimensions of capacitor and taping shall satisfy specified requirement. 电容器的尺寸和编带应满足规定		
3	Marking 标志		The marking shall be checked by 4x magnifying glass. 用 4 倍放大镜检查标志	Legible marking 标志易辨认		
4	Capacitance and tolerance 容量和误差		The capacitance shall be measured at 25°C with 1KHz 1±0.2 Vrms. 电容量测量条件: 25°C, 1KHz 1±0.2 Vrms	Refer to specification sheet 参照规格表		
5	Dissipation factor(D.F) 介质损耗		The dissipation factor shall be measured at 25°C with 1KHz 1±0.2 Vrms. 介质损耗测量条件: 25°C, 1KHz 1±0.2 Vrms.	0.1% max.		
6	Insulation resistance 绝缘电阻		The insulation resistance shall be measured with 100VDC within 60±5 sec of charging. 绝缘电阻测量条件: 100VDC, 充电 60±5 秒	Test A		Test B or Test C
				CR>0.33μF RC S	CR≤0.33μF R MΩ	R GΩ
				30000	100000	100
7	Dielectric Strength(Voltage Proof) 耐电压	Between Lead Wires 引线之间	The capacitor should not be damaged when test voltages of table below are applied between the lead wires for 60 sec. 在引线之间施加下表所示试验电压 60s, 电容器不会损坏。		Nofailure 不允许有失败	
			Type 类型	Test Voltage 试验电压		
			MPF	1.6 倍 Ur		
8	Robustness of Termination 引出端强度		The capacitor body shall be held in such a manner so that the axis of the lead is vertical. 电容器的本体应使用某种方式举起, 使得引线的轴心是垂直的 The tensile force of 10N(for lead of Ø0.6~Ø0.8mm) shall be applied to the lead in a direction of its axis and acting in a direction away from the body of the capacitor for 10±1 seconds. 沿轴心方向施加 10N 的拉力在引线上(引线直径为 0.6~ 0.8mm), 并往另一个方向拉, 使之远离电容器本体, 持续 10±1s.	No break in the lead, no damage in the capacitor body. 引线无断裂, 电容本体无破损		

9	Bending 弯曲度	<p>The capacitor body shall be held in such a manner so that the axis of the lead is vertical. A mass applying a force of 5N(for lead of Ø0.6~Ø0.8mm)is then suspended from the end of the lead. The body of the capacitor is then inclined within a period of 2 to 3 seconds , through an angle of approximately 90⁰ in the vertical plane and then returned to its initial position over the same period of time. This operation constitutes one bend. The lead shall be subjected to a total of 2 alternating bends in two opposite directions.</p> <p>电容器本体应使用某种方式举起，使引线的轴心是垂直的。施加 5N 的力于引线末端上（引线直径为 0.6~ 0.8mm）。电容器本体会倾斜 2 到 3 秒的时间，通过一个的 90⁰ 垂直版上面，然后将它放到最开始的位置维持同样的时间。这个测试构成一次弯曲测试。引线需要进行 2 次方向相反的弯曲测试。</p>	<p>No break in the lead, no damage in the capacitor body.</p> <p>引线无断裂,电容本体无破损</p>
10	Solderability Of leads 引线可焊性	<p>The lead wire of a capacitor should be dipped into molten solder for 2±0.5sec.</p> <p>引线应浸入软焊料 2±0.5 秒</p> <p>The depth of immersion is up to about 1.5 to 2.0mm from the root of lead wires.</p> <p>引线浸入深度大约为 1.5~2mm(从引线底端算起)</p> <p>Temp. of solder: Lead Free solder(Sn-3Ag-0.5Cu) 245±5℃ H63 Eutectic Solder 235±5℃ 焊料温度: 无铅焊料(锡-3 银-0.5 铜) 245±5℃ H63 共晶焊料 235±5℃</p>	<p>A new uniform coating of solder shall cover a minimum of 95% of the surface being immersed</p> <p>新的焊料涂层应均匀覆盖至少 95% 被浸入表面</p>
11	Solvent Resistance 耐溶剂性	<p>The capacitor shall be immersed into isopropyl alcohol for 30±5nds. seco</p> <p>电容器应浸入异丙醇中 30±5 秒</p>	<p>Appearance No visible damage 外观无明显损坏</p> <p>Legible marking 标志清晰</p>
12	Resistance to Soldering heat 耐焊接热	<p>Temperature of solder bath 260±5℃.</p> <p>The immersing depth of lead shall be a position 2-0.5mm from the seating plane, using a thermal screen. The thickness of the screen is 1.5±0.5mm.</p> <p>The immersion time shall be 10±1 seconds.</p> <p>Post-treatment: The capacitor shall be preserved at the standard atmospheric condition for 1 to 2 hours.</p> <p>焊浴温度: 260±5℃。引线浸入深度: 离底座 2-0.5mm。使用绝热板(厚度为 1.5±0.5mm)。浸入时间: 10±1 秒。</p> <p>后处理: 电容器应在标准大气压条件下放置 1-2 小时。</p>	<p>Appearance 外观: No visible damage: 外观没有明显损坏</p> <p>Dissipation Factor 介质损耗: (Increasing value 增加值)</p> <p>First class capacitors: ≤0.001(1KHz) Second class capacitors: ≤0.004(1KHz) 1 级电容: ≤0.001(1KHz) 2 级电容: ≤0.004(1KHz)</p> <p>Capacitance Change 电容量变化 (ΔC/C0):</p> <p>First class capacitors: ≤±1% of the initial vale Second class capacitors: ≤±3% of the initial vale 1 级电容: ≤初始值的±1% 2 级电容: ≤初始值的±3%</p>

<p>13</p>	<p>The steady state hot and humid 稳态湿热</p>	<p>The capacitor shall be stored for 21 days(500±8hours) at a temperature of 40℃±5℃ and a relative humidity of 93±2% 在 40℃±2℃、相对湿度 93±2% 条件下储存电容器 21 天 (500±8 小时)。 Pre-treatment:The capacitor shall be stored at a temperature of 85℃±2℃ for 1 hour ,and then the capacitor shall be recovered for 24±2 hours. 预处理：在温度 85℃±2℃ 下储存电容器 1 小时，然后电容器恢复 24±2 小时。 Post-treatment:The capacitor shall be stored for 1 to 2 hours at the standard atmospheric condition. (Temperature:15 to 35℃,Relative humidity:45 to 75%,Atmospheric pressure:86 to 106kPa) 后处理：在标准大气压下储存电容器 1-2 小时。(温度：15-35℃，相对湿度：45-75%，大气压力：86-106 千帕)</p>	<p>Appearance 外观: No visible damage: 外观没有明显损坏 Dissipation Factor 介质损耗: (Increasing value 增加值) First class capacitors: ≤0.001(1KHz) Second class capacitors: ≤0.002(1KHz) 1 级电容: ≤0.001(1KHz) 2 级电容: ≤0.002(1KHz) Capacitance Change 电容量变化 (ΔC/C0): First class capacitors: ≤±1% of the initial vale Second class capacitors: ≤±5% of the initial vale 1 级电容: ≤初始值的±1% 2 级电容: ≤初始值的±5% Insulation resistance 绝缘电阻: ≥50% of the initial value ≥初始值的 50%</p>
<p>14</p>	<p>Endurance test(life) 耐久性试验 (寿命)</p>	<p>the capacitors are placed at a temperature of 105℃ ±2℃ for 1000 hours. Throughout the test, the capacitors are subjected 50Hz/60Hz 1.25UR voltages 将电容器放置在 105℃±2℃ 下 1000 小时。在整个实验过程中，电容器应经受 50Hz/60Hz1.25UR 的电压 Post-treatment: the capacitor shall be preserved for 24±2 hours at standard atmospheric condition. 后处理：在标准大气压下，电容器恢复 24±2 小时。</p>	<p>Appearance 外观: No visible damage: 外观没有明显损坏 Dissipation Factor 介质损耗: (Increasing value 增加值) First class capacitors: ≤0.002(1KHz) Second class capacitors: ≤0.004(1KHz) 1 级电容: ≤0.002(1KHz) 2 级电容: ≤0.004(1KHz) Capacitance Change 电容量变化 (ΔC/C0): First class capacitors: ≤±1% of the initial vale Second class capacitors: ≤±5% of the initial vale 1 级电容: ≤初始值的±1% 2 级电容: ≤初始值的±5% Insulation resistance 绝缘电阻: ≥50% of the initial value ≥初始值的 50%</p>

Attach page 附页

浸渍型:

P0=12.7mm

☆ F=7.5→5 mm J 形

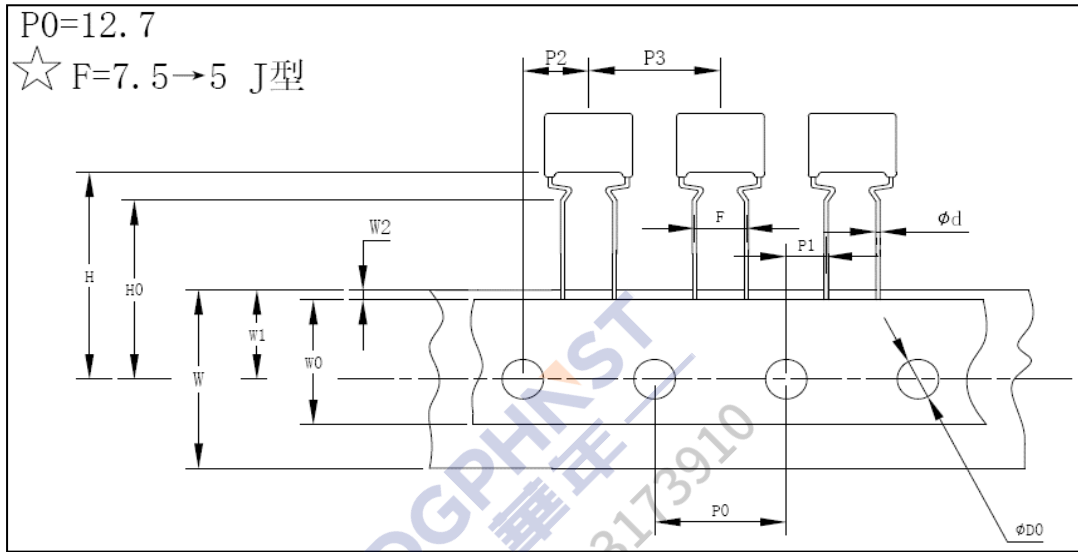

☆ F=10→7.5 mm J 形

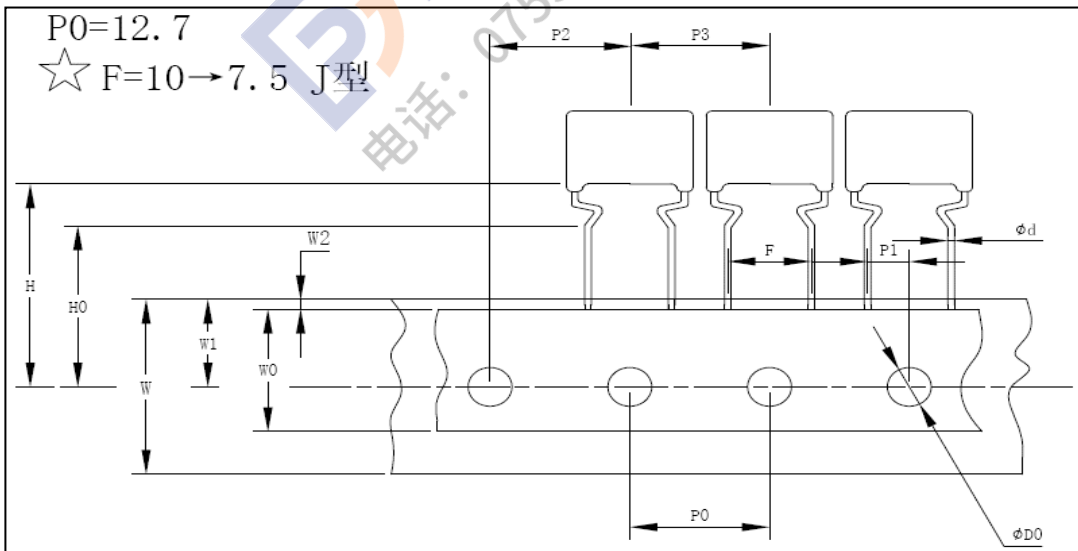

☆ F=10→5 mm Y 形

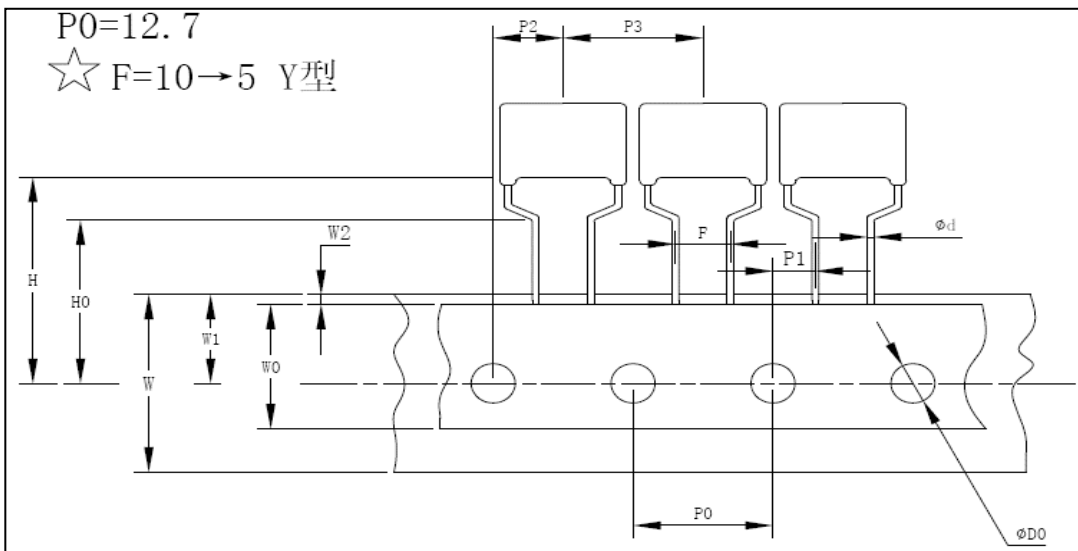

浸渍型:

P0=15.0mm

☆ F=7.5→5 mm J 形

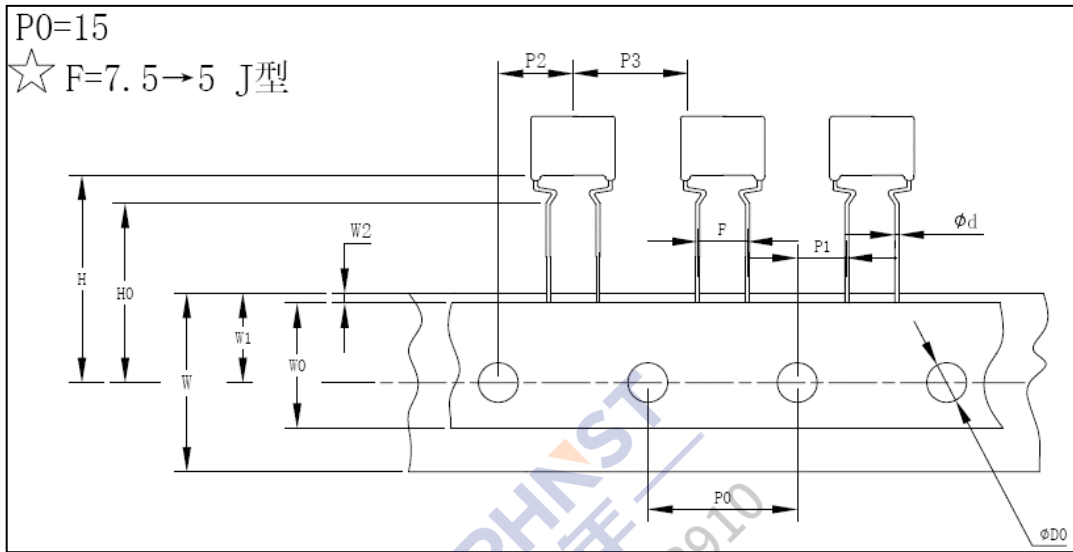

☆ F=10→7.5 mm J 形

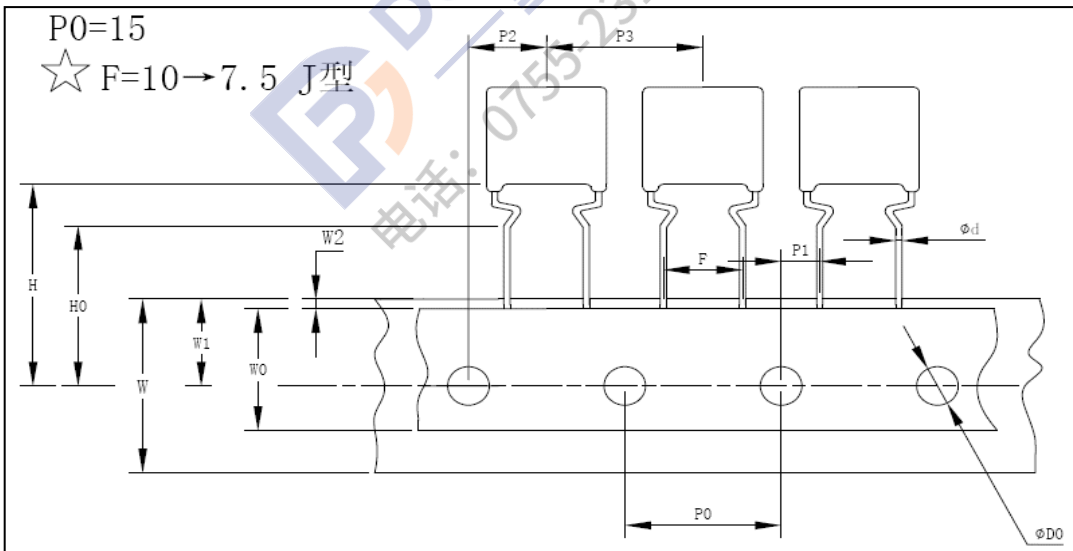

☆ F=10→5 mm Y 形

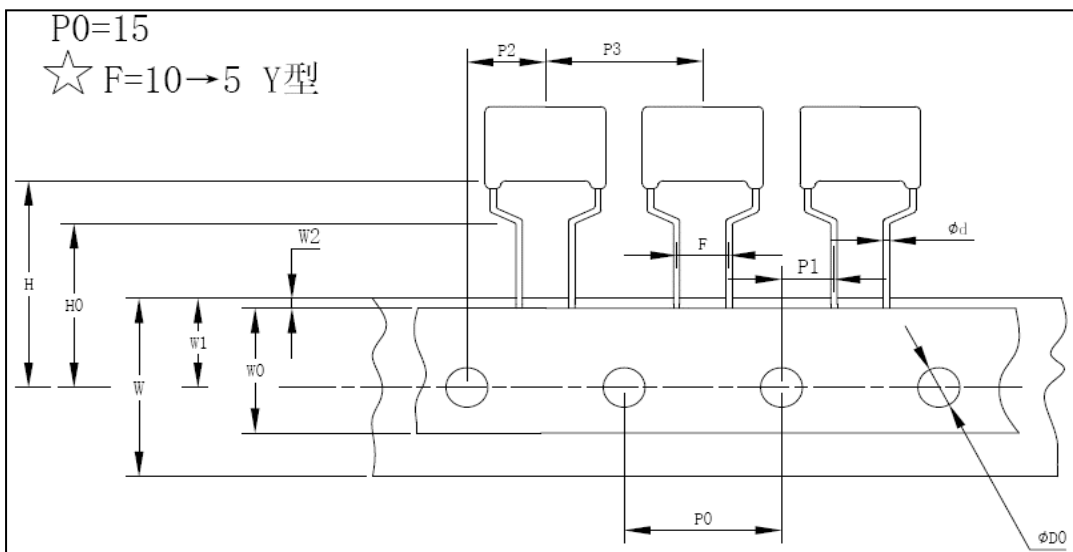

☆ F=7.5 mm L 形

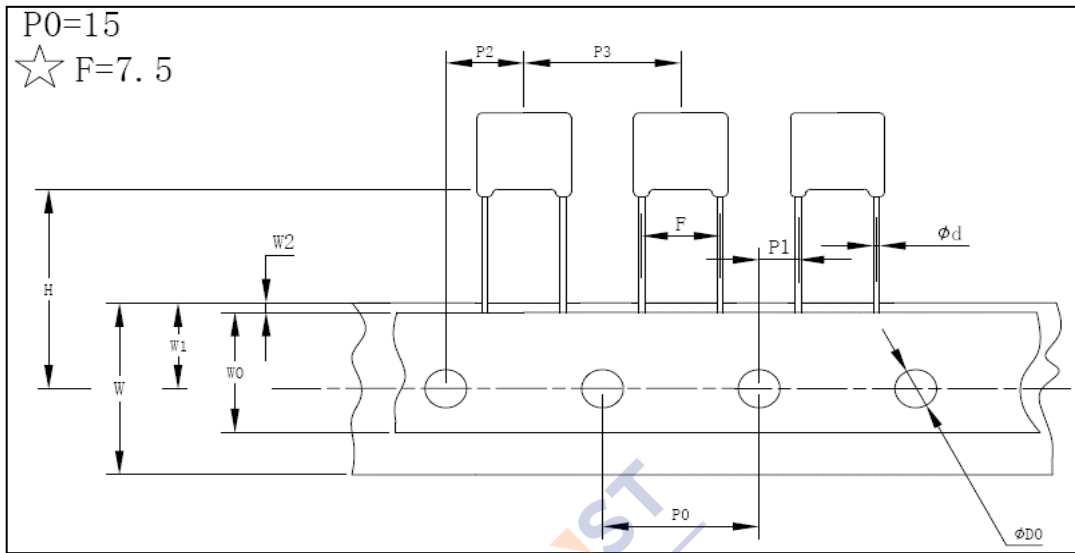

☆ F=10 mm L 形

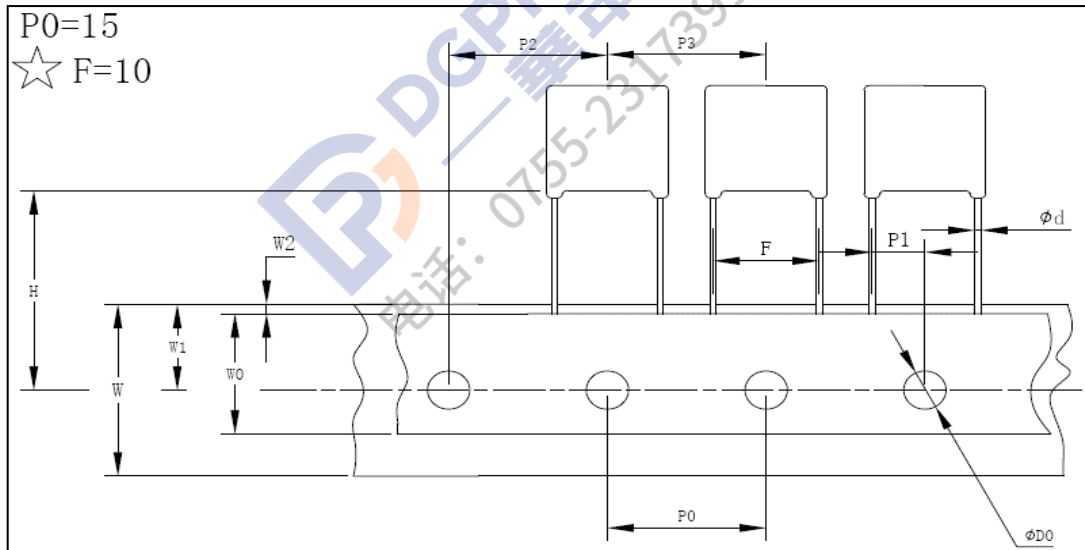

☆ F=15 mm L 形

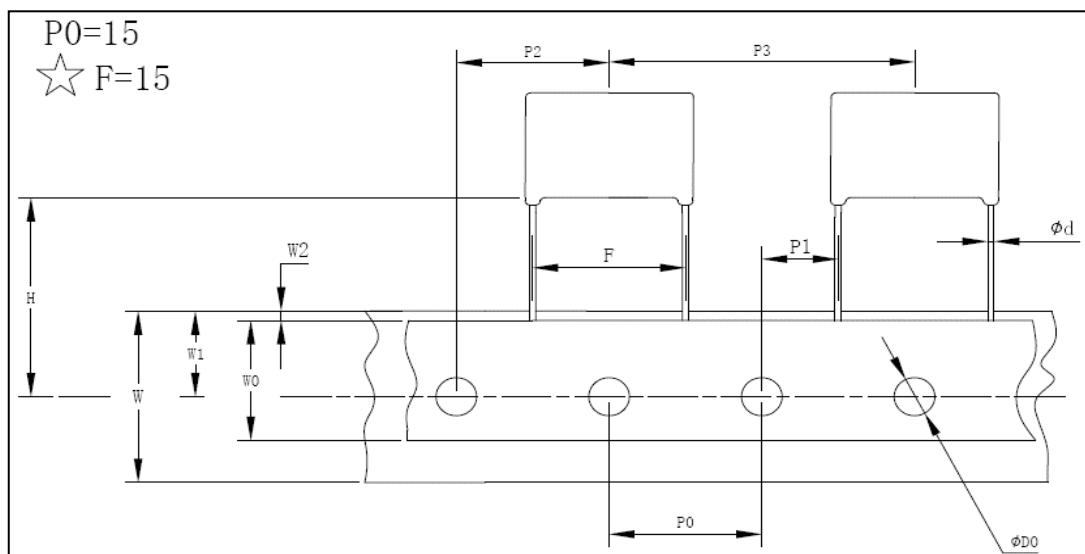

盒式:

P0=12.7mm

☆ F=7.5 mm L 形

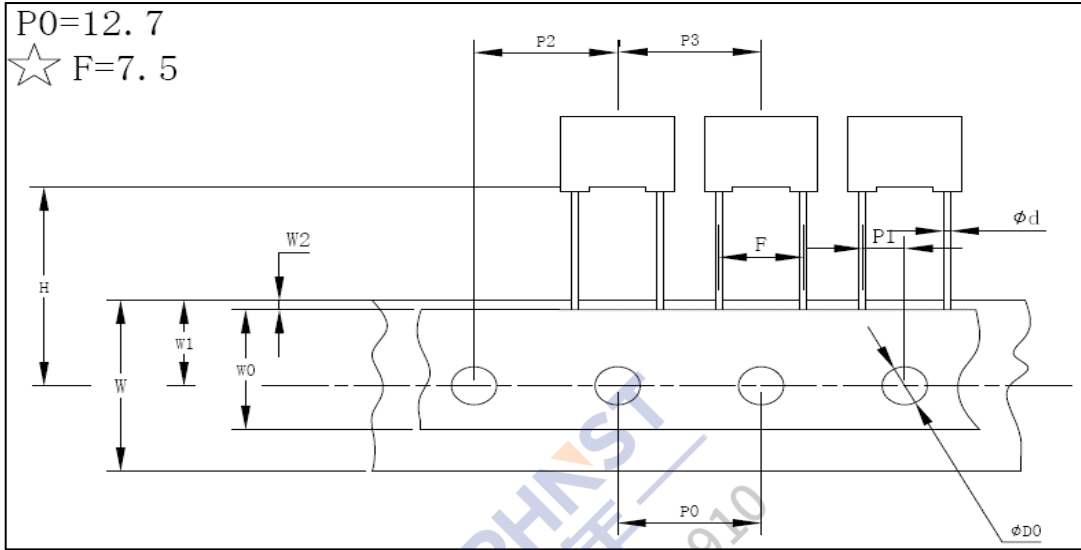

☆ F=10 mm L 形

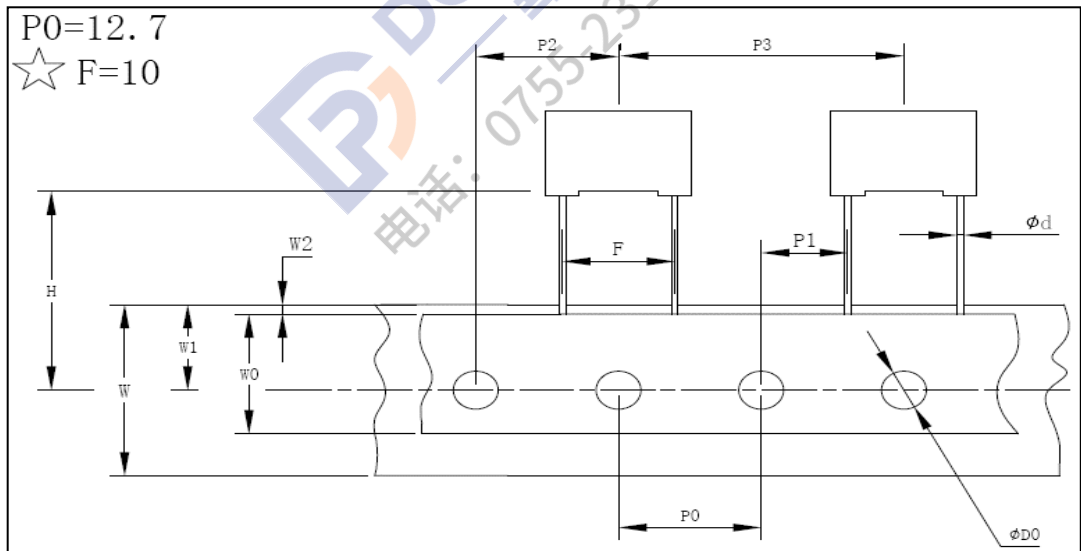

☆ F=15 mm L 形

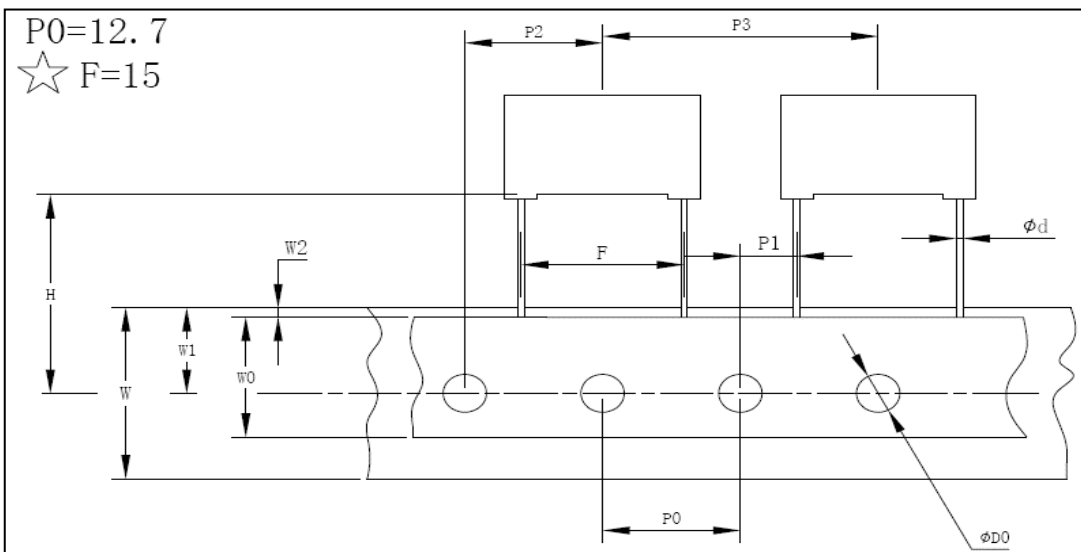

☆ F=7.5 mm L形

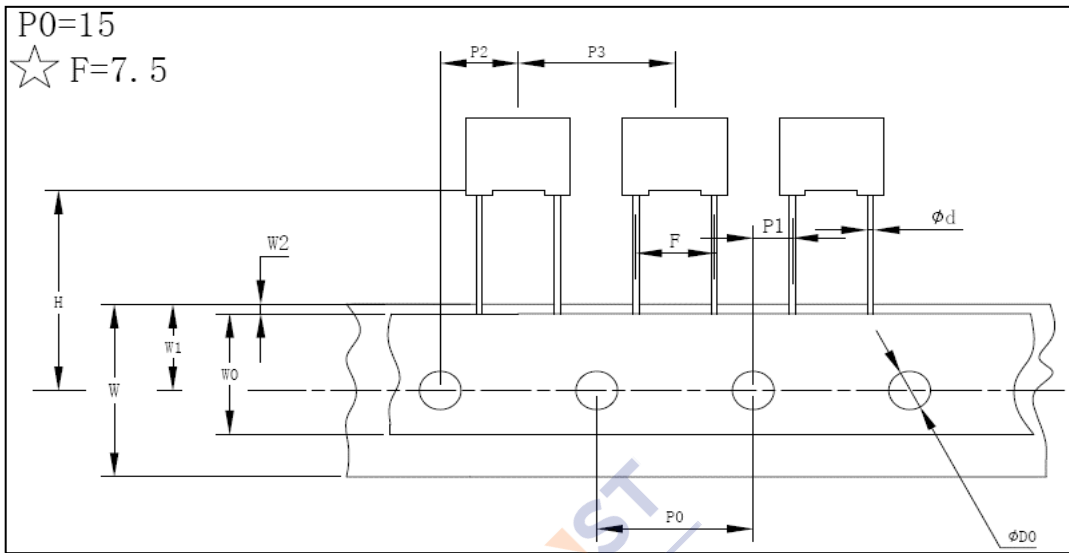

☆ F=10 mm L形

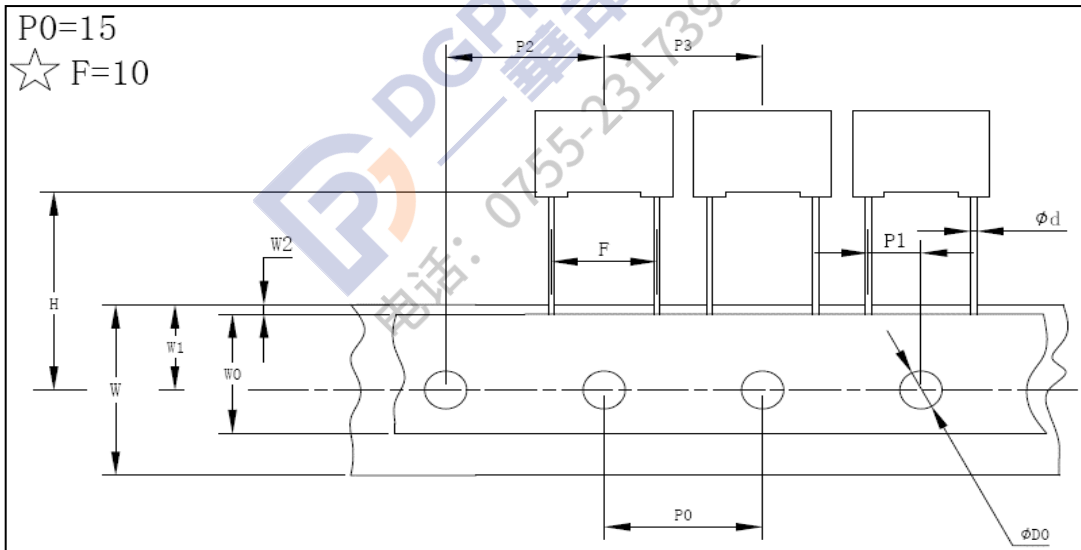

☆ F=15 mm L形

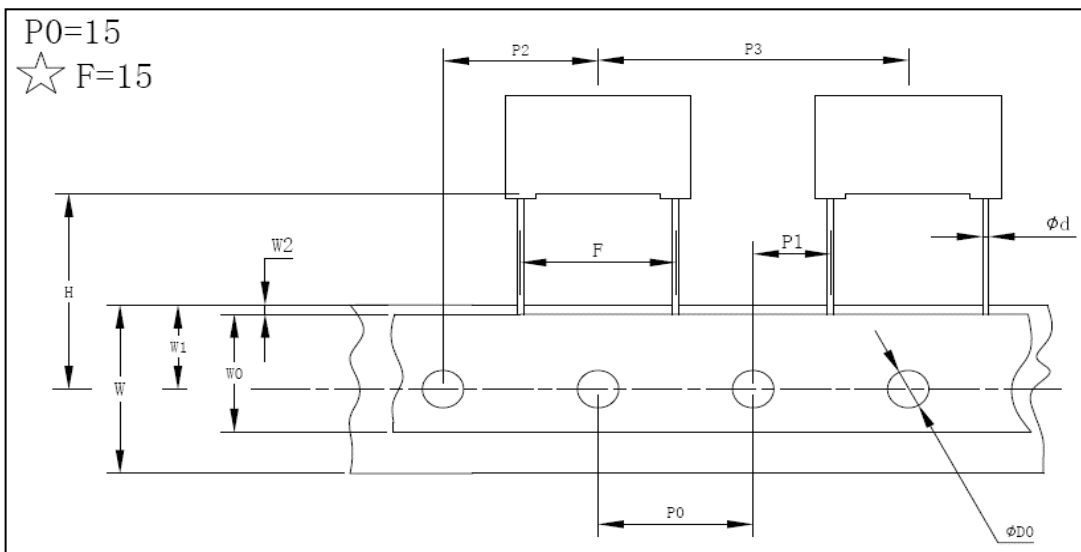

浸渍型:

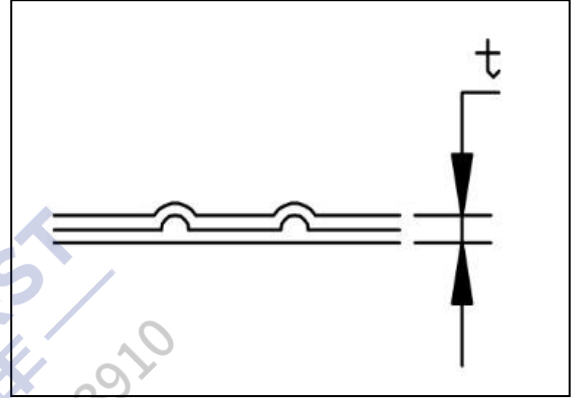
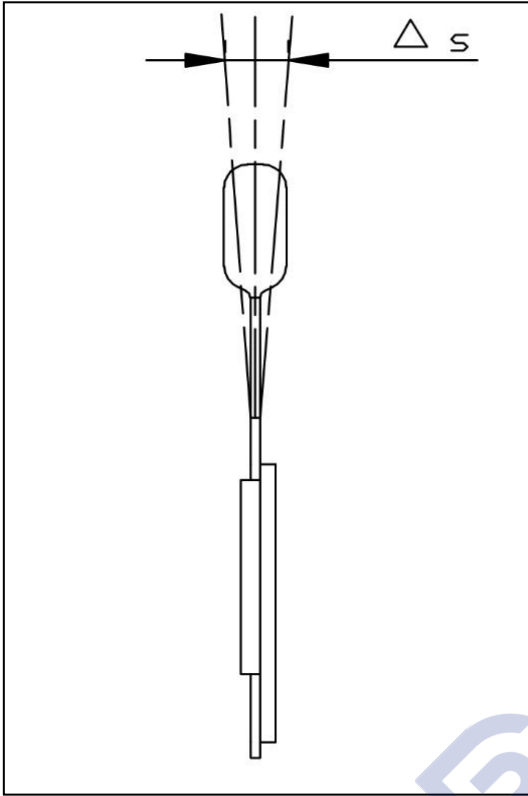

盒式:

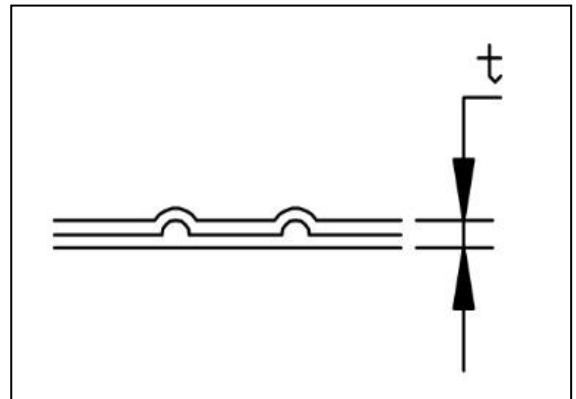
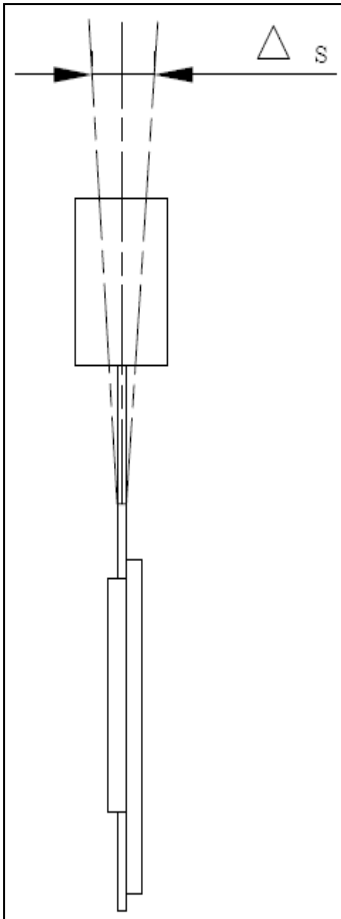

直脚品编带尺寸表：(mm)

符号	名称	S 型编带尺寸要求				T 型编带尺寸要求				误差
F	引线间距	5.0	7.5	10.0	15.0	5.0	7.5	10.0	15.0	±1.0
d	引线直径	0.6	0.6	0.6	0.8	0.6	0.6	0.6	0.8	±0.06
W	纸带宽度	18.0	18.0	18.0	18.0	18.0	18.0	18.0	18.0	+1.0/-0.5
W0	粘带宽度	10min	10min	10min	10min	10min	10min	10min	10min	/
W1	对输送孔的偏移	9.0	9.0	9.0	9.0	9.0	9.0	9.0	9.0	±0.5
W2	粘带边距	3 max	3 max	3 max	3 max	3 max	3 max	3 max	3 max	/
t	编带总厚度	0.6	0.6	0.6	0.6	0.6	0.6	0.6	0.6	±0.2
P0	输送孔间距	15.0	15.0	15.0	15.0	12.7	12.7	12.7	12.7	±0.3
D0	输送孔直径	4.0	4.0	4.0	4.0	4.0	4.0	4.0	4.0	±0.3
P1	对输送孔的偏移	5.0	3.75	5.0	7.5	3.85	3.75	7.7	5.2	±0.7
P2	对输送孔的偏移	7.5	7.5	15.0	15.0	6.35	12.7	12.7	12.7	±1.3
P3	编带间距	15.0	15.0	15.0	30.0	12.7	12.7	25.4	25.4	±1.0
H	输送孔到产品底部高度	18.5	18.5	18.5	18.5	18.5	18.5	18.5	18.5	±0.5
△S	电容器侧面倾斜	0	0	0	0	0	0	0	0	±2.0

成型品编带尺寸表：(mm)

符号	名称	S 型编带尺寸要求				T 型编带尺寸要求				误差
F	引线间距	5.0	7.5	10.0	15.0	5.0	7.5	10.0	15.0	±1.0
d	引线直径	0.6	0.6	0.6	0.8	0.6	0.6	0.6	0.8	±0.06
W	纸带宽度	18.0	18.0	18.0	18.0	18.0	18.0	18.0	18.0	+1.0/-0.5
W0	粘带宽度	10min	10min	10min	10min	10min	10min	10min	10min	/
W1	对输送孔的偏移	9.0	9.0	9.0	9.0	9.0	9.0	9.0	9.0	±0.5
W2	粘带边距	3 max	3 max	3 max	3 max	3 max	3 max	3 max	3 max	/
t	编带总厚度	0.6	0.6	0.6	0.6	0.6	0.6	0.6	0.6	±0.2
P0	输送孔间距	15.0	15.0	15.0	15.0	12.7	12.7	12.7	12.7	±0.3
D0	输送孔直径	4.0	4.0	4.0	4.0	4.0	4.0	4.0	4.0	±0.3
P1	对输送孔的偏移	5.0	3.75	5.0	7.5	3.85	3.75	7.7	5.2	±0.7
P2	对输送孔的偏移	7.5	7.5	15.0	15.0	6.35	12.7	12.7	12.7	±1.3
P3	编带间距	15.0	15.0	15.0	30.0	12.7	12.7	25.4	25.4	±1.0
H	输送孔到产品底部高度	16.0	16.0	16.0	16.0	16.0	16.0	16.0	16.0	±0.5
△S	电容器侧面倾斜	0	0	0	0	0	0	0	0	±2.0