



7 > (' % 6 ž 7 8 (' % 6 ' ' 5 X 1 g h U V ' Y ' 5 W W f U h ' F Y Z f Y b W W ' G c i f W W

GCH!& ' 9 b W U d g i ' U h ' 5 X 1 g h U V ' Y ' F Y Z f Y b W W ' G c i f W W

7 > (' % 6 ž 7 8 (' % 6 ' ' 5 X 1 g h U V ' Y ' 5 W W f U h ' F Y Z f Y b W W ' G c i f W W

% ' ' b h f c X i W h c b

The CJ431B, CD431B is a three-terminal adjustable shunt regulators with a specified thermal stability. The output voltage may be set to any value between V_{REF} (approx. 2.5V) and 36V with two external resistors. The active output circuitry provides a very sharp turn on characteristic making these devices an excellent replacement for zener diodes in many applications.

& ' ' ' : Y U h i f Y g

- Low Dynamic Output Impedance: 0.1Ω (Typ.)
- Reference Voltage V_{REF} Tolerance: $\pm 0.5\%$
- Adjustable Output Voltage
- Fast Turn-on Response
- Sink Current Capability: 0.1mA to 100mA
- Low Output Noise
- Industrial T_J Range: $-40 \sim 125^\circ\text{C}$
- Improved Temperature Compensation
- Excellent Temperature Coefficient: 25ppm/ $^\circ\text{C}$

' ' ' 5 d d '] W U h c b g

- Shunt Regulator
- High-Current Shunt Regulator
- Precision Current Limiter

(' ' ' ' D] b ' 7 c b Z [i f U h c b ' U b X ' A U f _] b [' b Z c f a U h c b

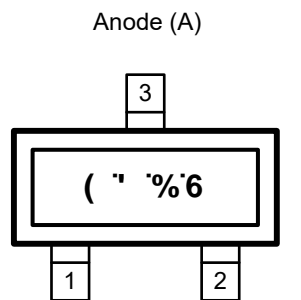

Reference (R) Cathode (K)

7 > (' % 6 ' GCH!& ' DUW U Y

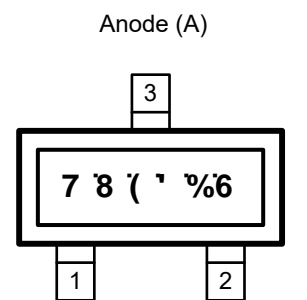

Cathode (K) Reference (R)

7 8 (' % 6 ' GCH!& ' DUW U Y

) ''GdYWZVUjcbg

) '%5 Vgc`i hY`A U] ja i a `FU]b[g

ft;j Yf`hYa dYfUi fYfUb[Yzi b`Ygg`cH Yfk JgY`gdYWZVYXL^{ftk}

7 < 5 F 5 7 H 9 F -GH7`	GMA 6 C @	J5 @ 9`	I B-H`
Cathode voltage ⁽²⁾	V _{KA}	40	V
Cathode current range (continuous)	I _{KA}	-100 ~ 150	mA
Reference input current range	I _{REF}	0.05 ~ 10	mA
Maximum junction temperature	T _{J Max}	150	°C
Storage temperature	T _{stg}	-65 ~ 150	°C
Soldering temperature & time	T _{solder}	260°C, 10s	-

(1) Stresses beyond those listed under *Absolute Maximum Ratings* may cause permanent damage to the device. These are stress ratings only, which do not imply functional operation of the device at these or any other conditions beyond those indicated under *Recommended Operating Conditions*. Exposure to absolute maximum rated conditions for extended periods may affect device reliability.

(2) All voltages are with respect to network ground terminal.

) '&`FYWLa a YbX`CdYfU]b[`7 cbX]hcbg

D5 F 5 A 9 H 9 F ^{ftk}	GMA 6 C @	A-B"	BCA "	A5 L "	I B-H`
Cathode voltage	V _{KA}	2.5	-	36	V
Cathode current	I _{KA}	0.3	-	100	mA
Operating junction temperature	T _J	-40	-	125	°C
Operating ambient temperature ⁽⁴⁾	T _A	-	-	-	°C

(3) JSCJ recommends that users should not exceed the rated value in the *Recommended Operating Conditions* for the application conditions of the device, so as to ensure the stability of normal operation and reliability of long-term operation of the device. Operation beyond the recommended rated conditions does not mean that the product will fail. The consumers need to evaluate the risks that may be caused by the operation of the product beyond the recommended rated conditions.

(4) It is necessary to ensure that the operating junction temperature of the equipment does not exceed the rated value of the recommended operating conditions when using the device for design.

) " `9G8`FU]b[g

9G8`F5H8; G`		GMA 6 C @	J5 @ 9`	I B-H`
Electrostatic discharge ⁽⁵⁾	Human body model	V _{ESD-HBM}	2500	V

(5) ESD testing is conducted in accordance with the relevant specifications formulated by the Joint Electronic Equipment Engineering Commission (JEDEC). The human body model (HBM) electrostatic discharge test is based on the JESD22-114D test standard, using a 100pF capacitor and discharging to each pin of the device through a resistance of 1.5kΩ.

) ' ' ' GdYVWZVWUjcbg

) ' (' ' H Yfa U ' : b Z : fa Ujcb

H<9FA5 @A9HF 7 ff L'	GMA6 C @	7 > (' % # 7 8 (' % 6	I B H'
Junction-to-ambient thermal resistance	R _{θJA}	GCH!&'	°C/W
		330.0	
Reference maximum power dissipation for continuous operation	P _{D Ref}	GCH!&'	W
		0.30	

(6) T_A = 25°C, all numbers are typical, and apply for packages soldered directly onto a PCB board in still air.

) ') ' ' 9 ' YWfjWU 7 \ UFUWYfjghjVg

7 > (' % Ž 7 8 (' % fH 5 ' 1 ' &) š 7 ži b ' Ygg'cH Yfk jgYgdYVWZVXL

7 < 5 F 5 7 H 9 F - GH 7	GMA6 C @	H9GH7 CB8 HCBG'		A-B''	HMD'ff L'	A5 L''	I B H'	
Reference input voltage	V _{REF}	Figure. 1	V _{KA} = V _{REF} , I _{KA} = 10mA	2.483	2.495	2.507	V	
Deviation of reference input voltage over temperature ⁽⁸⁾	V _{REF (DEV)}	Figure. 1	V _{KA} = V _{REF} , I _{KA} = 10mA, T _A = T _{MIN} to T _{MAX} ⁽⁹⁾	-	8.0	17	mV	
Ratio of change in reference input voltage to the change in cathode voltage	ΔV _{REF} / ΔV _{KA}	Figure. 2	ΔV _{KA} = 10V to V _{REF}	I _{KA} = 10mA	-	-1.0	-2.7	mV / V
			ΔV _{KA} = 36V to 10V		-	-0.4	-2.0	
Reference input current	I _{REF}	Figure. 2	I _{KA} = 10mA, R ₁ = 10kΩ, R ₂ = ∞	-	0.5	1.2	μA	
Deviation of reference input current over full temperature range	I _{REF (DEV)}	Figure. 2	I _{KA} = 10mA, R ₁ = 10kΩ, R ₂ = ∞, T _A = T _{MIN} to T _{MAX} ⁽⁹⁾	-	0.4	1.2	μA	
Minimum cathode current for regulation	I _{KA (MIN)}	Figure. 1	V _{KA} = V _{REF}	-	0.08	0.30	mA	
Off-state cathode current	I _{KA (OFF)}	Figure. 3	V _{KA} = 36V, V _{REF} = 0V	-	0.01	0.80	μA	
Dynamic impedance ⁽¹⁰⁾	Z _{KA}	-	V _{KA} = V _{REF} , I _{KA} = 0.2 to 100mA, f ≤ 1kHz	-	0.10	0.37	Ω	

) ' ' ' GdYVWZVWUjcbg

) ') ' ' 9 ` YWfjWU ` 7 \ UfUWYfjghjVg ` fWc b h j b i YXŁ

BchY.

(7) Typical numbers are at 25°C and represent the most likely norm.

(8) Deviation of reference input voltage, $V_{REF (DEV)}$, is defined as the maximum variation of the reference input voltage over the full temperature range:

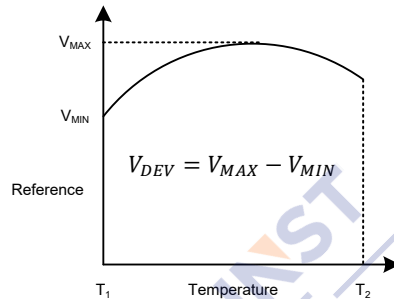

Different from αV_{REF} in ppm, the average temperature coefficient of reference input voltage αV_{REF} is defined as:

$$\alpha V_{REF} \frac{ppm}{^\circ C} = \frac{\pm [\frac{V_{MAX} - V_{MIN}}{V_{REF} (at 25^\circ C)}] \times 10^6}{T_2 - T_1} = \frac{\pm [\frac{V_{DEV}}{V_{REF} (at 25^\circ C)}] \times 10^6}{T_2 - T_1}$$

where, $T_2 - T_1$ = full temperature change, V_{REF} can be positive or negative depending on whether the slope is positive or negative.

(9) $T_{MIN} = -25^\circ C$, $T_{MAX} = 125^\circ C$.

(10) The dynamic output impedance, Z_{KA} , is defined as:

$$Z_{KA} = \frac{\Delta V_Z}{\Delta I_Z}$$

when the device is programmed with two external resistors, R_1 and R_2 , the dynamic output impedance of the overall circuit, Z_{KA} , is defined as:

$$Z_{KA} = \frac{\Delta V_Z}{\Delta I_Z} \cong [Z_{KA} \times (1 + \frac{R_1}{R_2})]$$

6 Typical Characteristics and Test Circuits

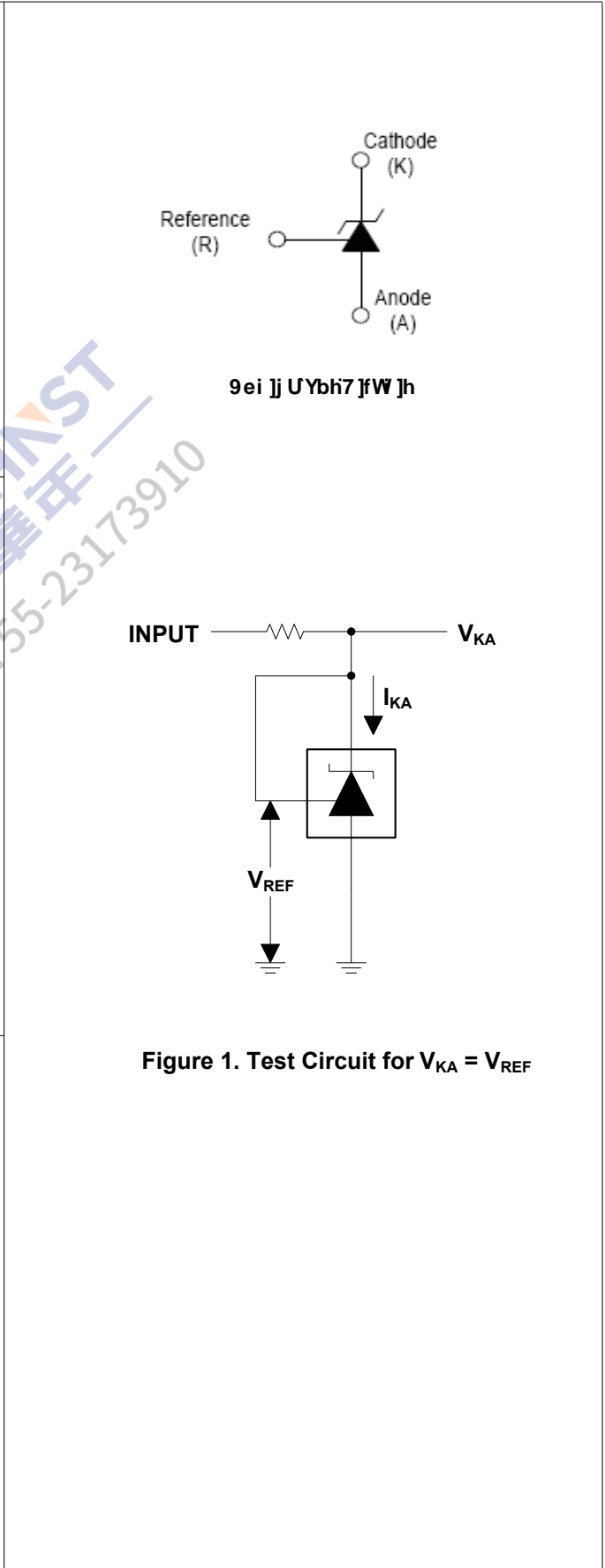
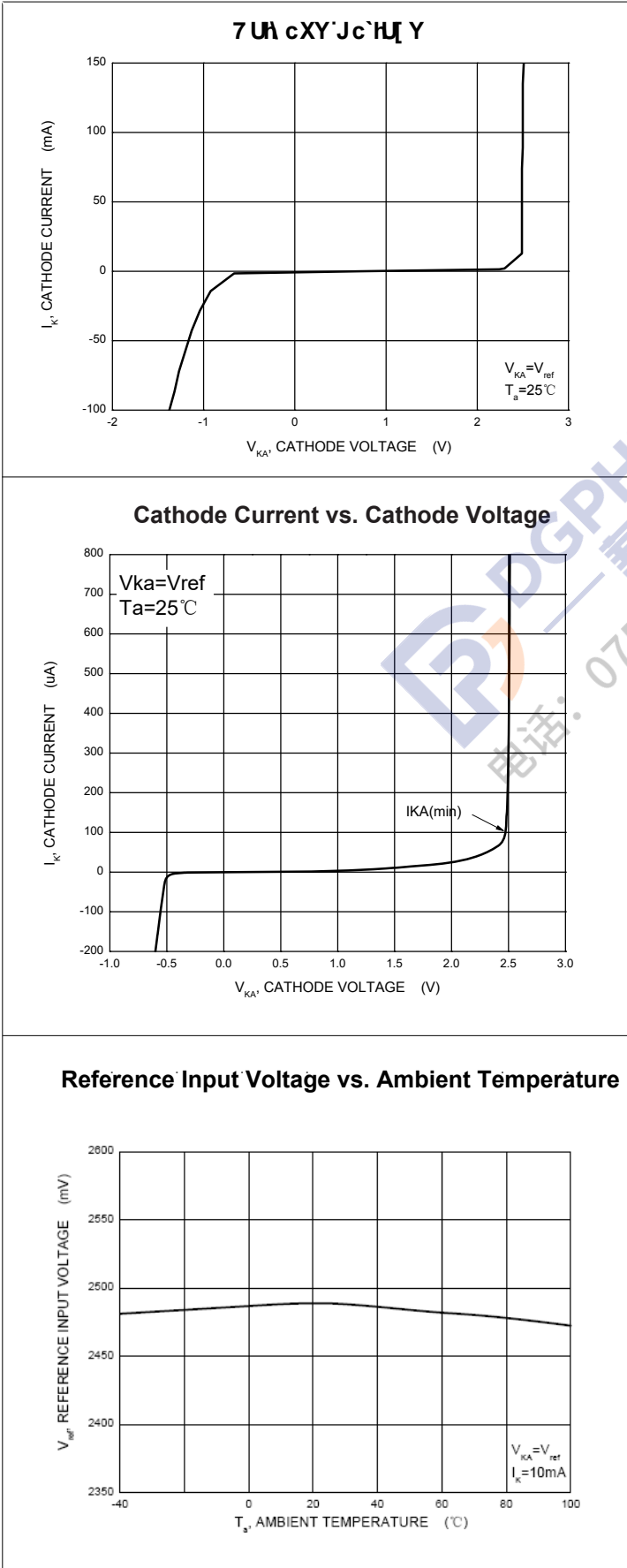

*Hmd]WU`7\ UFUWYf]gh]Wg`UbX`HYgh7]fW]hg

Change in Reference Input Voltage vs. Cathode Voltage

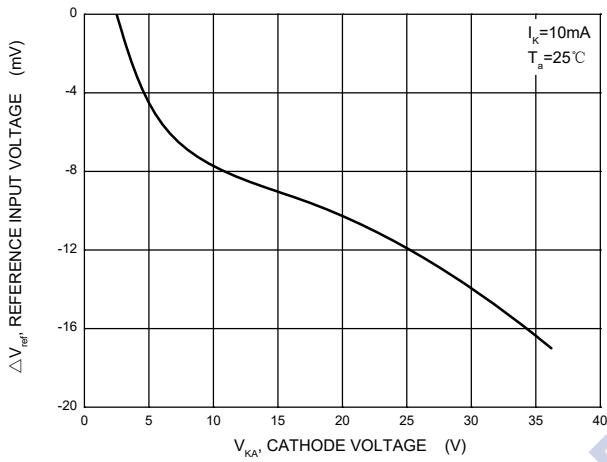

Reference Input Current vs. Ambient Temperature

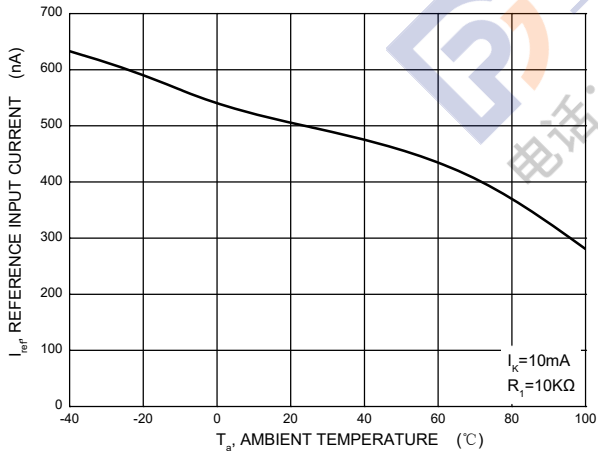

Off-State Cathode Current vs. Ambient Temperature

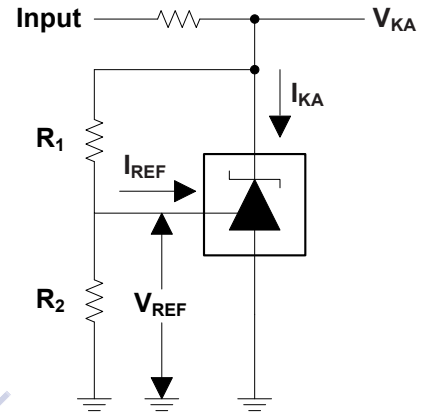
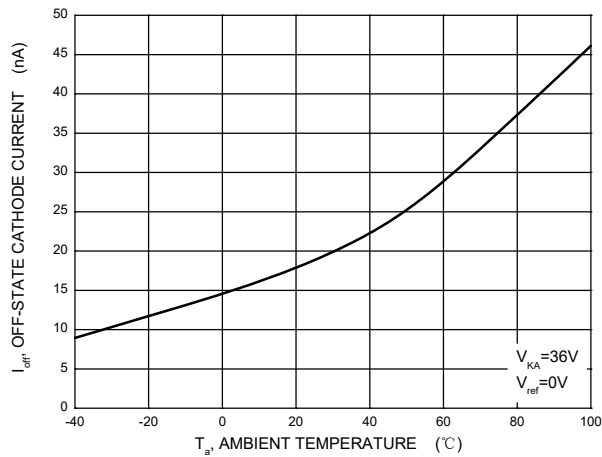

Figure 2. Test Circuit for V_{KA} > V_{REF}
 $V_{KA} = V_{REF} \times (1 + R_1 / R_2) + R_1 \times I_{REF}$

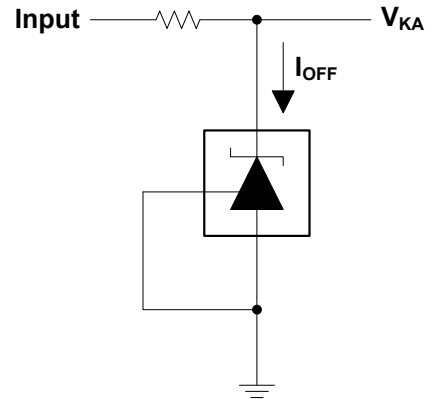

Figure 3. Test Circuit for I_{OFF}

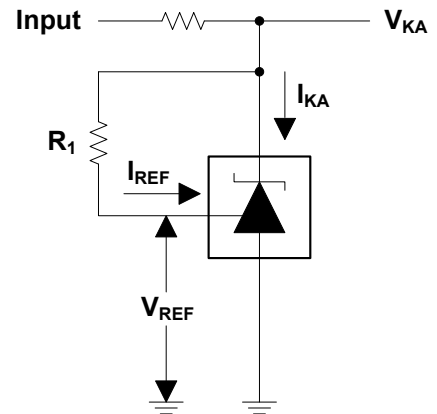
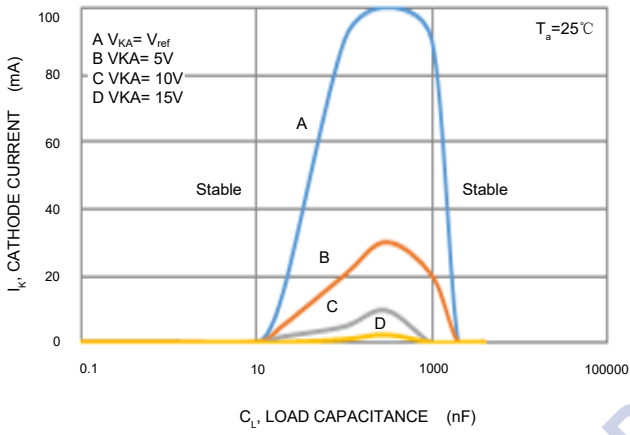

Figure 4. Test Circuit for I_{REF}

* Hnd]WU`7\ UFUWYf]gh]Wg`UbX`HYgh7]fW]hg

Stability Boundary Conditions



Note:

The areas under the curves represent conditions that may cause the device to oscillate. For curves B, C, and D, R_2 and $V+$ are adjusted to establish the initial V_{KA} and I_{KA} conditions, with $C_L = 0$. V_{BATT} and C_L then are adjusted to determine the ranges of stability.

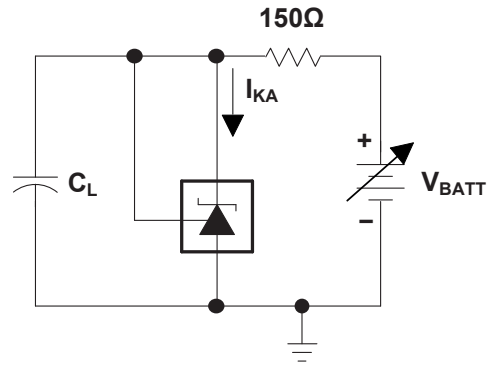

Figure 5. Test Circuit for $V_{KA} = V_{REF}$

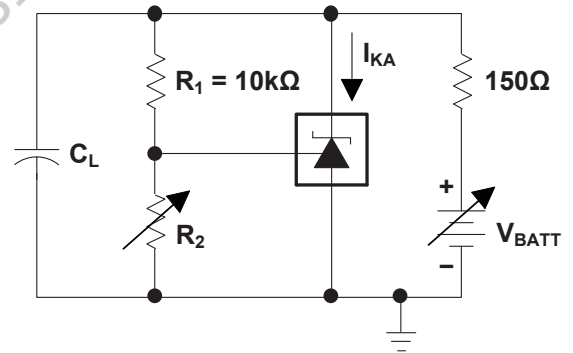
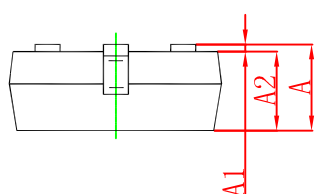
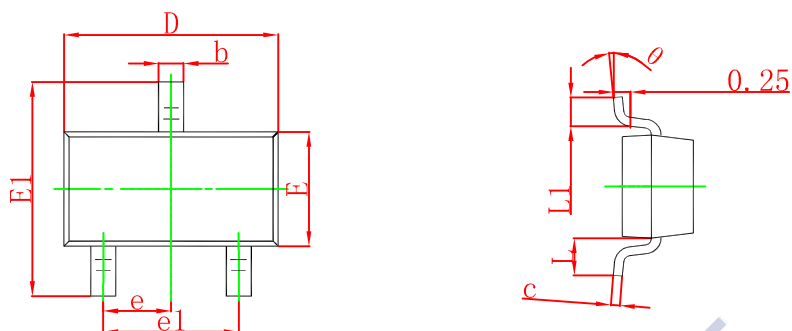

Figure 6. Test Circuit for $V_{KA} = V_{REF} \times (1 + R_1 / R_2) + R_1 \times I_{REF}$

7 Mechanical Information

SOT-23 Mechanical Information

Package Outline Dimensions



Symbol	Dimensions In Millimeters		Dimensions In Inches	
	Min	Max	Min	Max
A	0.900	1.150	0.035	0.045
A1	0.000	0.100	0.000	0.004
A2	0.900	1.050	0.035	0.041
b	0.300	0.500	0.012	0.020
c	0.080	0.150	0.003	0.006
D	2.800	3.000	0.110	0.118
E	1.200	1.400	0.047	0.055
E1	2.250	2.550	0.089	0.100
e	0.950 TYP		0.037 TYP	
e1	1.800	2.000	0.071	0.079
L	0.550 REF		0.022 REF	
L1	0.300	0.500	0.012	0.020
theta	0°	8°	0°	8°

Suggested Pad Layout

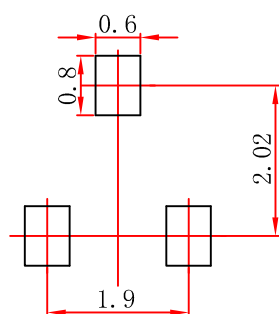

NOTE:

1. Controlling dimension: in millimeters.
2. General tolerance: $\pm 0.05\text{mm}$.
3. The pad layout is for reference purposes only.

8 Package Information

SOT-23 Package Information

SOT-23 Embossed Carrier Tape

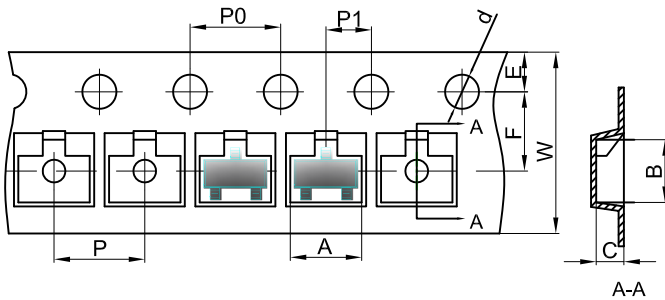

Packaging Description:
 SOT-23 parts are shipped in tape. The carrier tape is made from a dissipative (carbon filled) polycarbonate resin. The cover tape is a multilayer film (Heat Activated Adhesive in nature) primarily composed of polyester film, adhesive layer, sealant, and anti-static sprayed agent. These reeled parts in standard option are shipped with 3,000 units per 7" or 17.8cm diameter reel. The reels are clear in color and is made of polystyrene plastic (anti-static coated).

Dimensions are in millimeter

Pkg type	A	B	C	d	E	F	P0	P	P1	W
SOT-23	3.15	2.77	1.22	Ø1.50	1.75	3.50	4.00	4.00	2.00	8.00

SOT-23 Tape Leader and Trailer

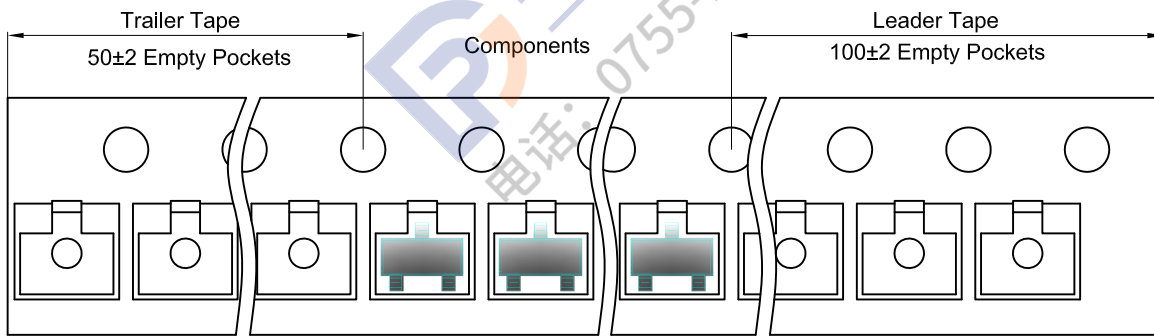

SOT-23 Reel

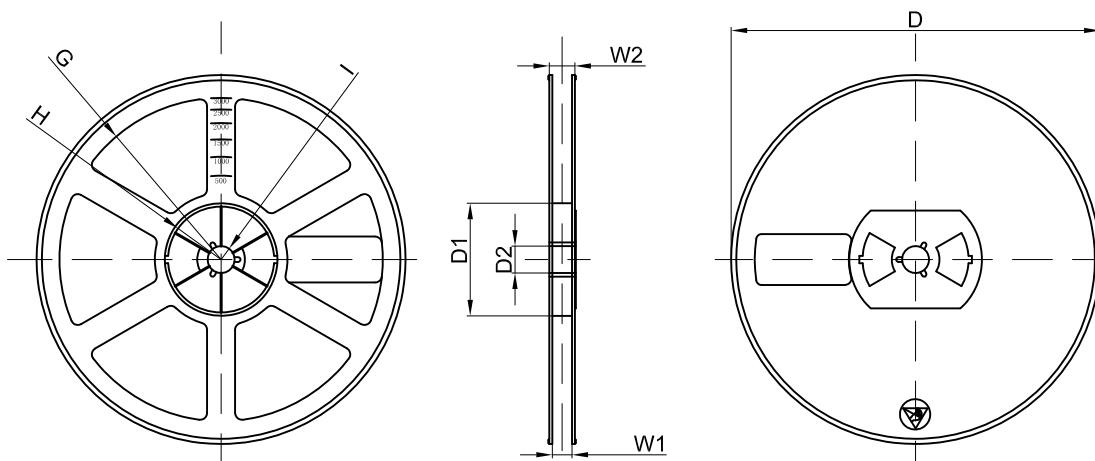

Dimensions are in millimeter

Reel Option	D	D1	D2	G	H	I	W1	W2
7"Dia	Ø178.00	54.40	13.00	R78.00	R25.60	R6.50	9.50	12.30

REEL	Reel Size	Box	Box Size(mm)	Carton	Carton Size(mm)	G.W.(kg)
3000 pcs	7 inch	45,000 pcs	203×203×195	180,000 pcs	438×438×220	

9 Notes and Revision History

9.1 Associated Product Family and Others

To view other products of the same type or IC products of other types, please click the official website of JSCJ -- <https://www.jscj-elec.com> for more details.

9.2 Notes

Electrostatic Discharge Caution



This IC may be damaged by ESD. Relevant personnel shall comply with correct installation and use specifications to avoid ESD damage to the IC. If appropriate measures are not taken to prevent ESD damage, the hazards caused by ESD include but are not limited to degradation of integrated circuit performance or complete damage of integrated circuit. For some precision integrated circuits, a very small parameter change may cause the whole device to be inconsistent with its published specifications.

9.3 Revision History

December, 2022: changed from rev - 2.2 into rev - 3.0:

- Changed the data sheet layout to JSCJ format;
- Added CD431B device to the data sheet.

PHYSICS
電話: 0755-23173910

DISCLAIMER

IMPORTANT NOTICE, PLEASE READ CAREFULLY

The information in this data sheet is intended to describe the operation and characteristics of our products. JSCJ has the right to make any modification, enhancement, improvement, correction or other changes to any content in this data sheet, including but not limited to specification parameters, circuit design and application information, without prior notice.

Any person who purchases or uses JSCJ products for design shall: 1. Select products suitable for circuit application and design; 2. Design, verify and test the rationality of circuit design; 3. Procedures to ensure that the design complies with relevant laws and regulations and the requirements of such laws and regulations. JSCJ makes no warranty or representation as to the accuracy or completeness of the information contained in this data sheet and assumes no responsibility for the application or use of any of the products described in this data sheet.

Without the written consent of JSCJ, this product shall not be used in occasions requiring high quality or high reliability, including but not limited to the following occasions: medical equipment, military facilities and aerospace. JSCJ shall not be responsible for casualties or property losses caused by abnormal use or application of this product.

Official Website: www.jscj-elec.com

Copyright © JIANGSU CHANGJING ELECTRONICS TECHNOLOGY CO., LTD.