



LM317C Three-Terminal Adjustable Regulator

1 Introduction

LM317C is a three terminal positive voltage regulator with maximum 1.5A current output and adjustable output. The voltage regulator is very easy to use, which only needs two external resistors to set the output voltage, and the output voltage can be set in the range of 1.2V to 37V. In addition, the LM317C is also designed to integrate internal current limiting, thermal shutdown and safe working area compensation, which makes it relatively difficult to damage and basically prevent the burning of circuit fuses.

LM317C serves a variety of applications, including local voltage stabilization and card voltage stabilization. It can also be used to make a programmable voltage regulator, or as a precision current regulator by connecting a fixed resistance between the adjustment point and the output.

2 Available Package

PART NUMBER	PACKAGE
LM317C	SOT-223
	TO-220-3L
	TO-252-2L
	TO-263-2L

Note: For more detailed packaging information, see the part *Pin Configuration and Function* and the part *Mechanical Information*.

3 Features

- The output current exceeds 1.5A
- The output is adjustable from 1.2 V to 37 V
- Internal thermal overload protection
- Temperature independent internal short circuit current limit
- Output transistor safe working area compensation
- Commonly used TO-252 package, as well as other forms of three pin package
- Avoid preparing multiple fixed voltages

4 Applications

- Ethernet Switch, Public Server, Private Switch (PBX)
- Base Station
- Desktop Computer
- IP Telephone: Wired and Wireless
- Motor Control
- Refrigerator, Air Conditioner, Washing Machine
- Security Camera, Digital Sign
- Signal or Waveform Generator
- Substation Control, Power Quality Meter

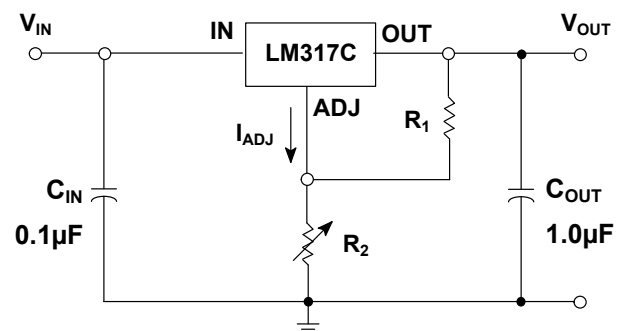

Figure 4-1. Typical Application Circuits

5 Orderable Information

MODEL	DEVICE	PACKAGE	OP T _J	ECO PLAN	MSL	PACKING OPTION	SORT
LM317C	-	SOT-223	-40 ~ 125°C	RoHS & Green	Level 3 168 HR	Tape and Reel 2500 Units / Reel	Active
	-	TO-220-3L	-40 ~ 125°C	RoHS & Green	Level 3 168 HR	Tube 50 Units / Rail	Active
	-	TO-252-2L	-40 ~ 125°C	RoHS & Green	Level 3 168 HR	Tape and Reel 2500 Units / Reel	Active
	-	TO-263-2L	-40 ~ 125°C	RoHS & Green	Level 3 168 HR	Tape and Reel 800 Units / Reel	Customized
Others	-	-	-	-	-	-	Customized

Note:

ECO PLAN: For the RoHS and Green certification standards of this product, please refer to the official report provided by JSCJ.

MSL: Moisture Sensitivity Level. Determined according to JEDEC industry standard classification.

SORT: Specifically defined as follows:

Active: Recommended for new products;

Customized: Products manufactured to meet the specific needs of customers;

Preview: The device has been released and has not been fully mass produced. The sample may or may not be available;

NoRD: It is not recommended to use the device for new design. The device is only produced for the needs of existing customers;

Obsolete: The device has been discontinued.

6 Pin Configuration and Marking Information

6.1 Pin Configuration and Function

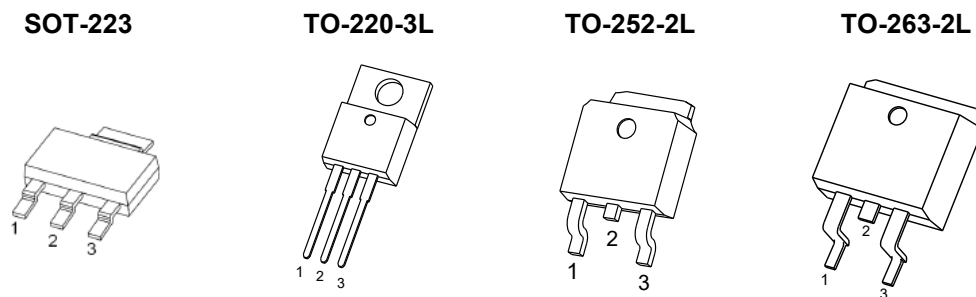
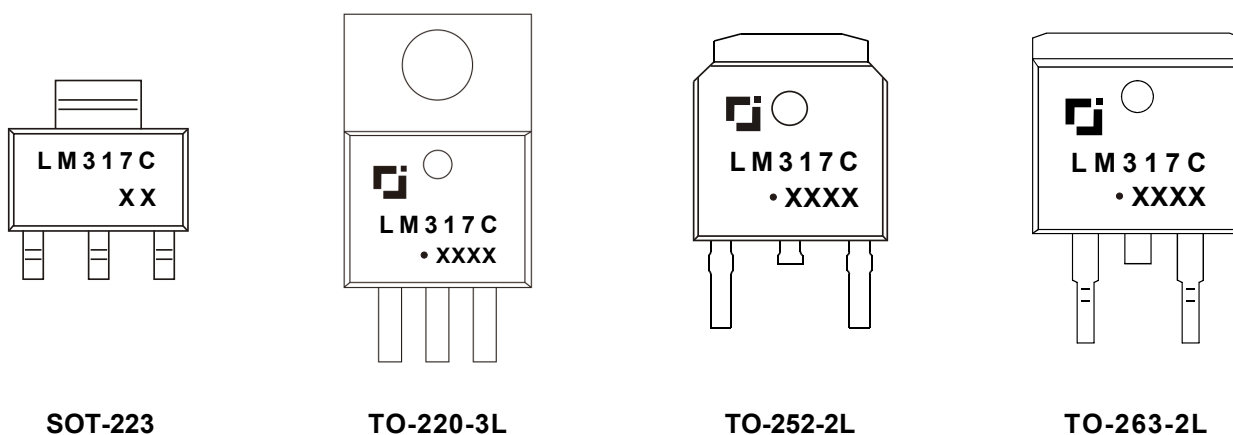

Figure 6-1. Package Top View

PIN NAME	LM317C				I/O	DESCRIPTION
	SOT-223	TO-220-3L	TO-252-2L	TO-263-2L		
IN	3	3	3	3	I	Supply input pin.
ADJ	1	1	1	1	-	Adjustment pin. Connect to a resistor divider to set V_{OUT} .
OUT	2	2	2	2	O	Voltage output pin.

6.2 Marking Information



"LM317C" : Device number.

"XX" & "XXXX" : Code. Indicates weekly record information of production.

" · " : Green molding compound device.

7 Specifications

7.1 Absolute Maximum Ratings⁽¹⁾

(over operating free-air temperature range, unless otherwise specified)

CHARACTERISTIC		SYMBOL	VALUE	UNITS
Maximum Input-to-output differential voltage		$V_{IN} - V_{OUT}$	40	V
Programmable output voltage range		V_{OUT}	1.2 ~ 37	
Maximum power dissipation	LM317C	SOT-223	Internally Limited ⁽²⁾	W
		TO-220-3L		
		TO-252-2L		
		TO-263-2L		
Maximum junction temperature		$T_{J Max}$	150	°C
Storage temperature		T_{stg}	-65 ~ 150	°C
Soldering temperature & time		T_{solder}	260°C, 10s	-

(1) Stresses beyond those listed under *Absolute Maximum Ratings* may cause permanent damage to the device. These are stress ratings only, which do not imply functional operation of the device at these or any other conditions beyond those indicated under *Recommended Operating Conditions*. Exposure to absolute-maximum rated conditions for extended periods may affect device reliability.

(2) All voltages are with respect to network ground terminal.

(3) Refer to *Thermal Information* for details.

7.2 Recommended Operating Conditions⁽⁴⁾

PARAMETER	SYMBOL	MIN.	NOM.	MAX.	UNIT
Input-to-output differential voltage	$V_{IN} - V_{OUT}$	3.0	-	40	V
Programmable output voltage	V_{OUT}	1.2	-	37	V
Output current range	I_{OUT}	0.01	-	1.5	A
Operating junction temperature	T_J	-40	-	125	°C
Operating ambient temperature	T_A	-	-(5)	-	°C

(4) JSCJ recommends that users should not exceed the rated value in the *Recommended Operating Conditions* for the application conditions of the equipment, so as to ensure the stability of normal operation and reliability of long-term operation of the equipment. Operation beyond the recommended rated conditions does not mean that the product will fail. The consumers need to evaluate the risks that may be caused by the operation of the product beyond the recommended rated conditions.

(5) It is necessary to ensure that the operating junction temperature of the equipment does not exceed the rated value of the recommended operating conditions when using the device for design.

7 Specifications

7.3 ESD Ratings

ESD RATINGS		SYMBOL	VALUE	UNIT
Electrostatic discharge ⁽⁶⁾	Human body model	$V_{ESD-HBM}$	2000	V
	Machine model	V_{ESD-MM}	200	

(6) ESD testing is conducted in accordance with the relevant specifications formulated by the Joint Electronic Equipment Engineering Commission (JEDEC). The human body mode (HBM) electrostatic discharge test is based on the JESD22-114D test standard, using a 100pF capacitor and discharging to each pin of the device through a resistance of 1.5kΩ. The electrostatic discharge test in mechanical mode (MM) is based on the JESD22-115-A test standard and uses a 200pF capacitor to discharge directly to each pin of the device.

7.4 Thermal Information

THERMAL METRIC ⁽⁷⁾	SYMBOL	LM317C		UNIT
		SOT-223	TO-220-3L	
Junction-to-ambient thermal resistance	$R_{\theta JA}$	100.0	66.7	°C/W
		TO-252-2L	TO-263-2L	
		80.0	62.5	
		TO-252-2L	TO-263-2L	
Junction-to-case thermal resistance	$R_{\theta JC}$	27.0	5.5	°C/W
		TO-252-2L	TO-263-2L	
		14.5	5.5	
		TO-252-2L	TO-263-2L	
Maximum power dissipation for continuous operation	$P_{D Ref}$	1.00	1.50	W
		TO-252-2L	TO-263-2L	
		1.25	1.60	
		TO-252-2L	TO-263-2L	

(7) $T_A = 25^\circ\text{C}$, see the part *Notes* for more information about thermal metrics.

7 Specifications

7.5 Electrical Characteristics

LM317C ($V_{IN} - V_{OUT} = 5.0V$, $I_{OUT} = 500mA$, $C_{IN} = 1\mu F$, $C_{OUT} = 1\mu F$, unless otherwise specified)

CHARACTERISTIC	SYMBOL	TEST CONDITIONS ⁽⁸⁾		MIN.	TYP. ⁽⁹⁾	MAX.	UNIT	
Line regulation	LNR ⁽¹⁰⁾	$V_{IN} - V_{OUT} = 3.0$ to $40V$		$T_J = 25^\circ C$	-	0.01	0.04	%V
				$T_J = 0$ to $125^\circ C$	-	0.02	0.07	
Load regulation	LDR	$I_{OUT} = 10$ to $1500mA$	$V_{OUT} < 5.0V$	$T_J = 25^\circ C$	-	5.0	25	mV
				$T_J = 0$ to $125^\circ C$	-	20	70	
			$V_{OUT} \geq 5.0V$	$T_J = 25^\circ C$	-	0.1	0.5	%· V_{OUT}
				$T_J = 0$ to $125^\circ C$	-	0.3	1.5	
ADJUST terminal current	I_{ADJ}	-		$T_J = 25^\circ C$	-	50	100	μA
Change in ADJUST terminal current	ΔI_{ADJ}	$V_{IN} - V_{OUT} = 2.5$ to $40V$ $I_{OUT} = 10$ to $1500mA$		$T_J = 25^\circ C$	-	0.2	5.0	μA
Reference voltage	V_{REF}	$V_{IN} - V_{OUT} = 3.0$ to $40V$ $I_{OUT} = 10$ to $1500mA$		$T_J = 25^\circ C$	1.20	1.25	1.30	V
Line regulation of reference voltage	LNR V_{REF}	$V_{IN} - V_{OUT} = 3.0$ to $40V$		$T_J = 25^\circ C$	-	0.02	0.07	%V
Load regulation of reference voltage	LDR V_{REF}	$I_{OUT} = 10$ to $1500mA$	$V_{OUT} < 5.0V$	$T_J = 25^\circ C$	-	20	70	mV
			$V_{OUT} \geq 5.0V$	$T_J = 25^\circ C$	-	0.3	1.5	%· V_{OUT}
Output voltage temperature stability	$\Delta V_{OUT} / V_{OUT}$	-		$T_J = 0$ to $125^\circ C$	-	1.0	-	%
Minimum load current to maintain regulation	$I_{OUT MIN}$	$V_{IN} - V_{OUT} = 40V$		$T_J = 0$ to $125^\circ C$	-	3.5	10	mA
Maximum output current	$I_{OUT MAX}$	$V_{IN} - V_{OUT} \leq 15V$		$T_J = 0$ to $125^\circ C$	1.5	2.2	-	A
		$V_{IN} - V_{OUT} = 40V$		$T_J = 25^\circ C$	0.15 ⁽¹¹⁾	0.4 ⁽¹¹⁾	-	
Output noise voltage (percentage of V_{OUT})	eN	$f = 10$ to $10kHz$		$T_J = 25^\circ C$	-	0.003	-	%
Ripple rejection	RR	$V_{IN} - V_{OUT} = (5.0V_{DC} \pm 1.0V_{PP AC})$, $f = 120Hz$	$C_{ADJ}^{(12)} = 0\mu F$	$T_A = 25^\circ C$	-	55	-	dB
			$C_{ADJ}^{(12)} = 10\mu F$		60	64	-	

7 Specifications

7.5 Electrical Characteristics (continued)

Note:

- (8) Pulse testing techniques are used to maintain the junction temperature as close to the ambient temperature as possible.
- (9) Typical numbers represent the most likely norm.
- (10) The line regulation is calculated by the following formula:

$$LNR = \frac{\Delta V_{OUT}}{V_{OUT} \times \Delta V_{IN}}$$

where, ΔV_{OUT} is the variation of the output voltage, ΔV_{IN} is the variation of the input voltage.

(11) It is not recommended to output current exceeding 0.15A under the condition of 40V voltage difference between input and output of the device. Under this condition, the output current of more than 0.15A will cause serious internal heating of the device, which will affect the stability of long-term operation of the device, and even cause damage to the device.

(12) C_{ADJ} is connected between the ADJ terminal and GND.

7.6 Typical Characteristics

LM317C ($C_{IN} = 0.1\mu F$, $C_{OUT} = 1\mu F$, unless otherwise specified)

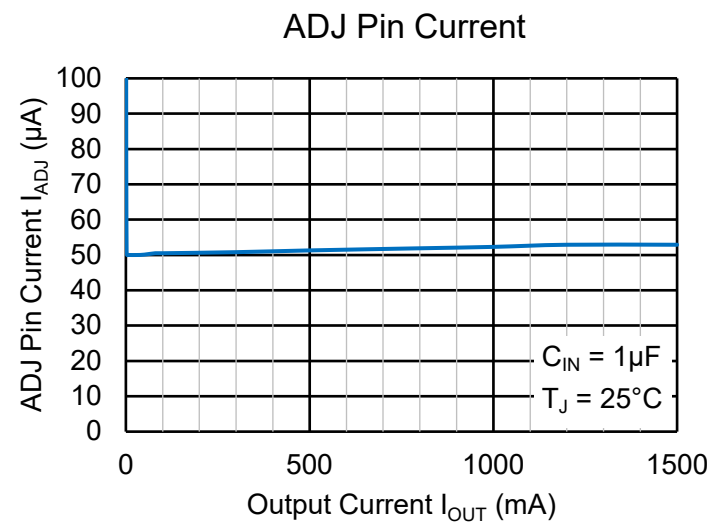
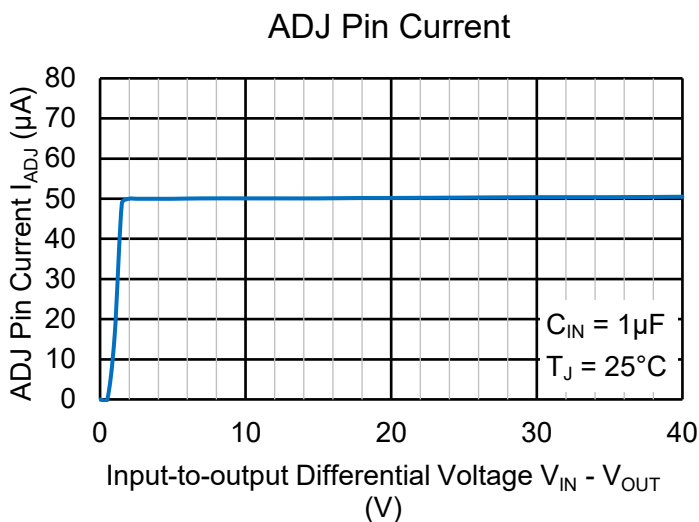
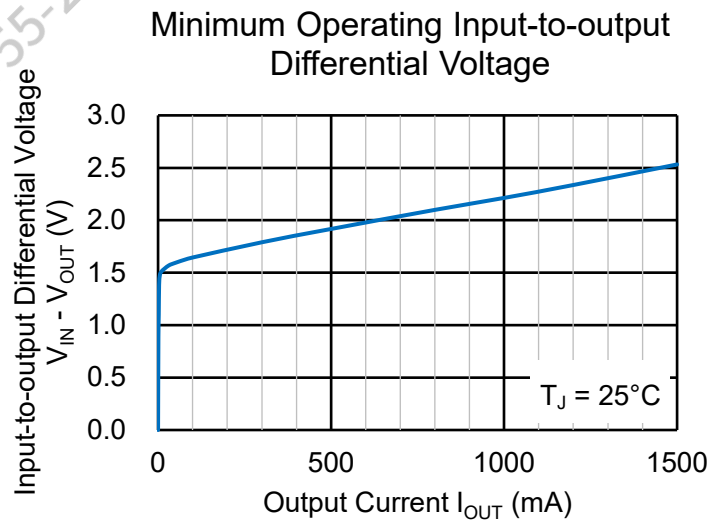
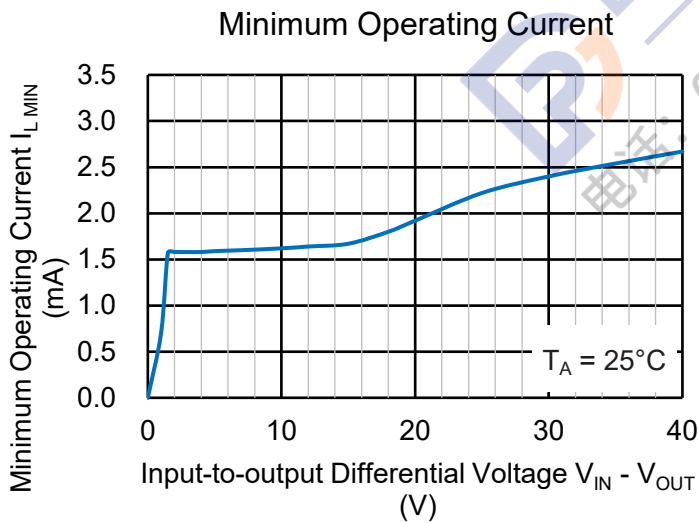

7 Specifications

7.6 Typical Characteristics (continued)

LM317C ($C_{IN} = 0.1\mu F$, $C_{OUT} = 1\mu F$, unless otherwise specified)

Line Regulation

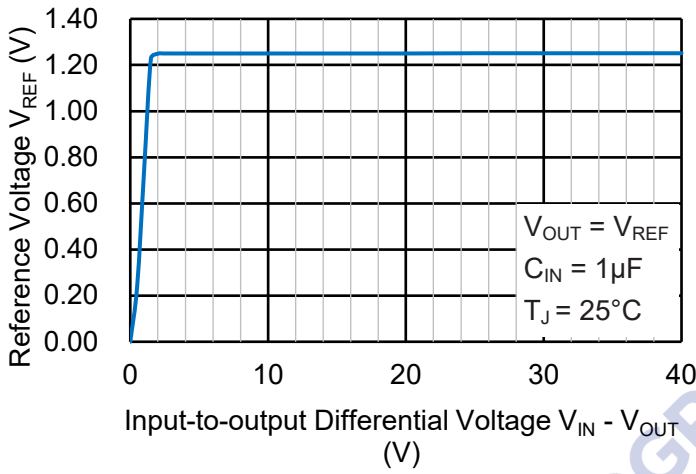

Line Regulation

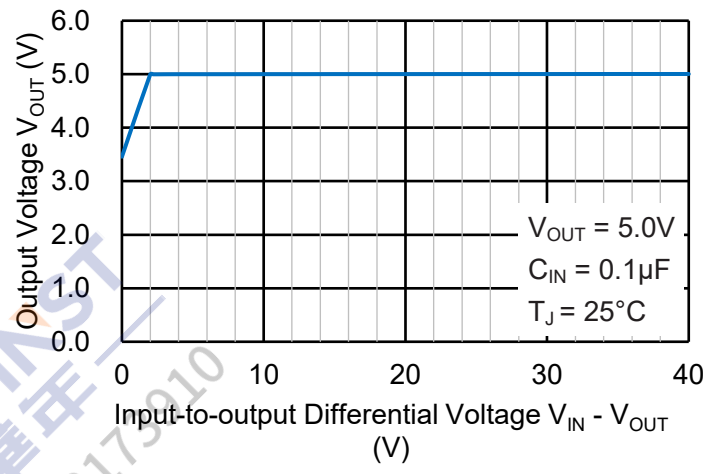

Line Regulation

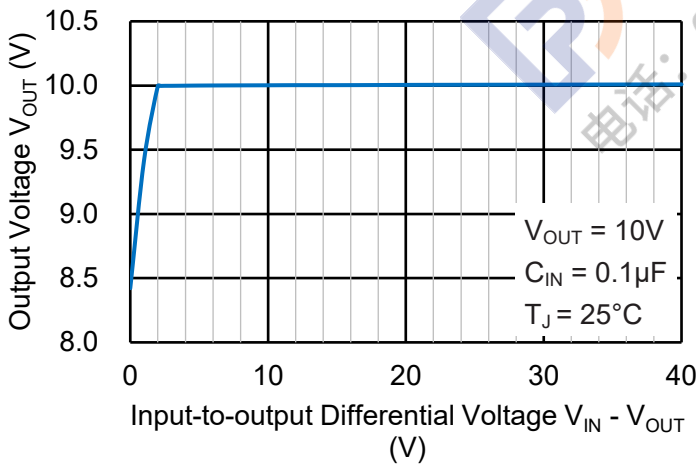

Load Regulation

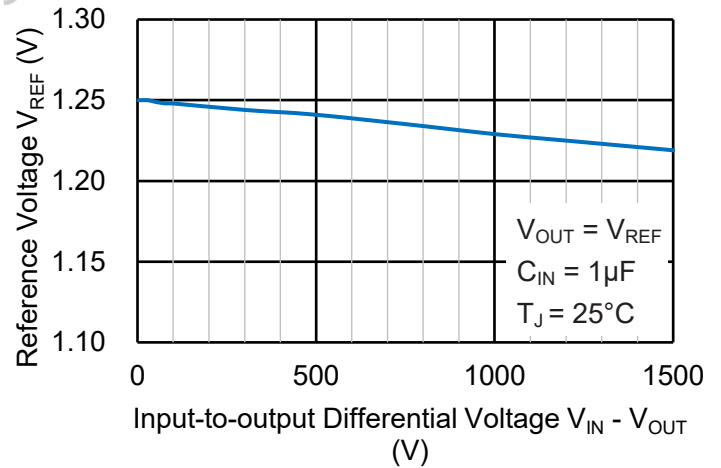

Load Regulation

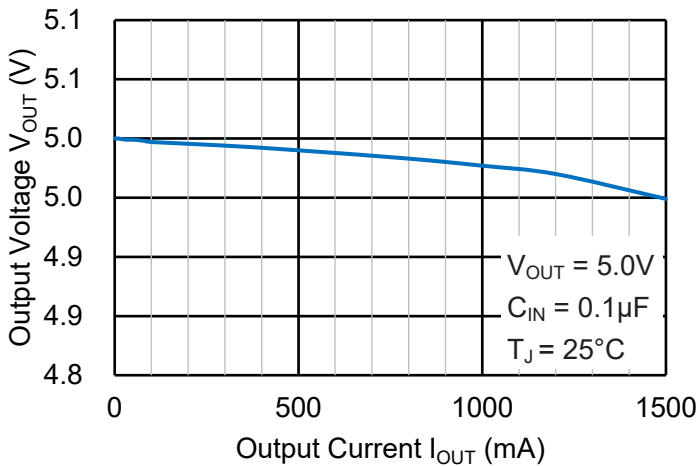

Load Regulation

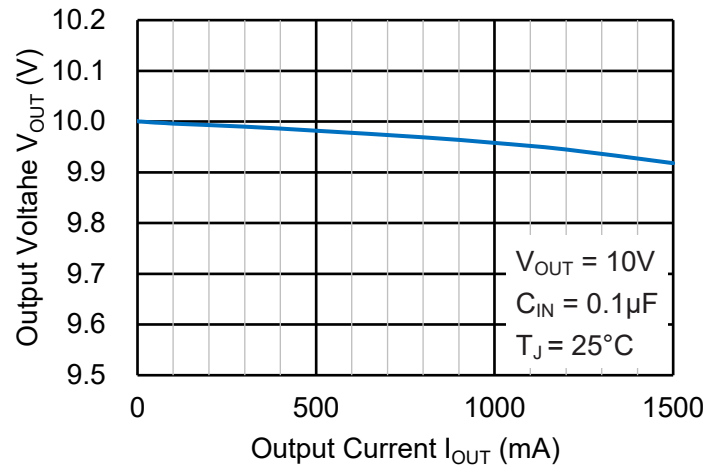

7 Specifications

7.6 Typical Characteristics (continued)

LM317C ($C_{IN} = 0.1\mu\text{F}$, $C_{OUT} = 1\mu\text{F}$, unless otherwise specified)

Power Supply Rejection Ratio

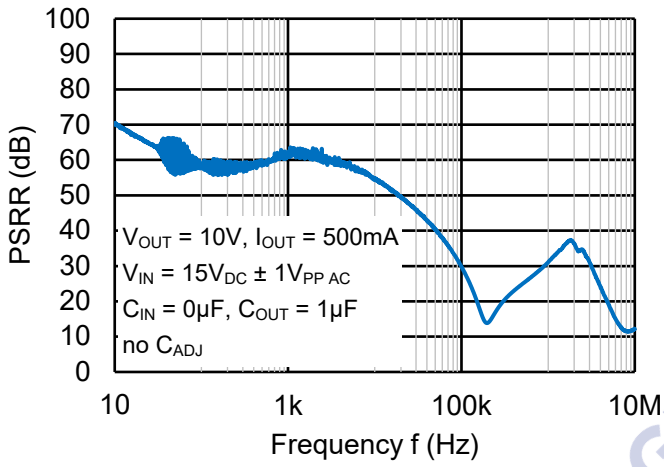

Power Supply Rejection Ratio

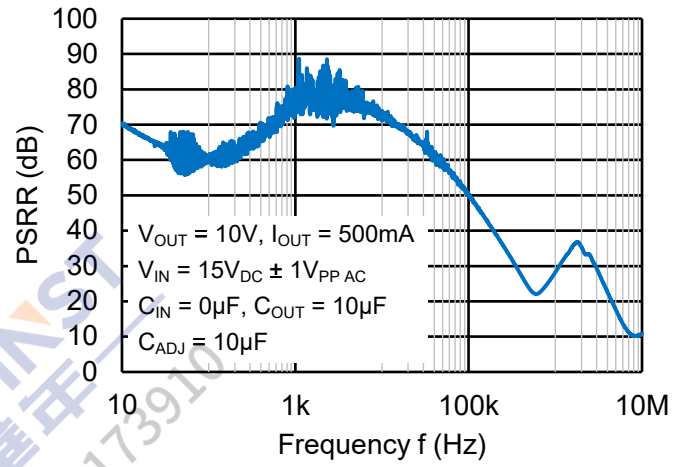

Current Limit

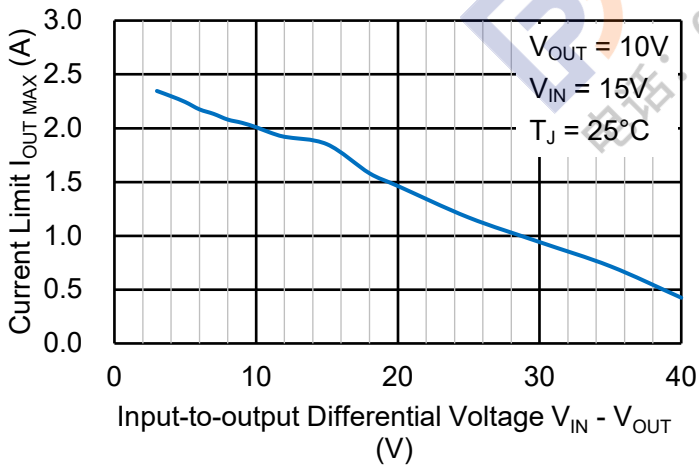

7 Specifications

7.6 Typical Characteristics (continued)

LM317C ($C_{IN} = 0.1\mu\text{F}$, $C_{OUT} = 1\mu\text{F}$, $T_A = 25^\circ\text{C}$, unless otherwise specified)

Load Transient Response

$V_{OUT} = 10\text{V}$, $V_{IN} = 15\text{V}$, $I_{OUT} = 10$ to 1000mA , CH2: V_{OUT} , CH4: I_{OUT}

$C_{ADJ} = 0\mu\text{F}$

$C_{ADJ} = 10\mu\text{F}$

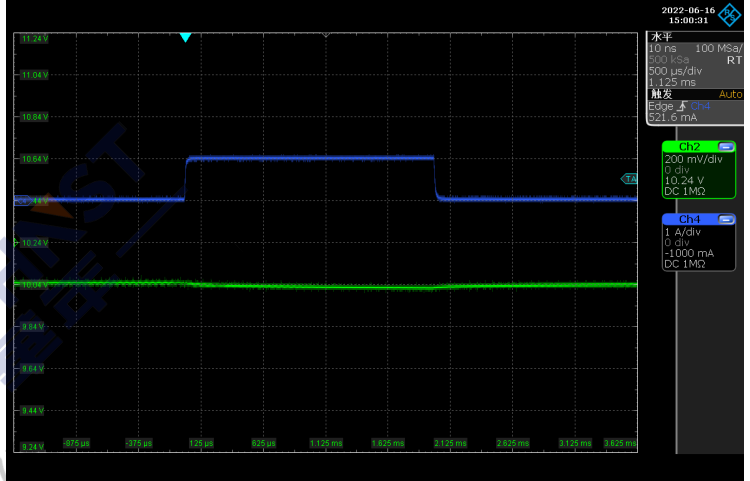
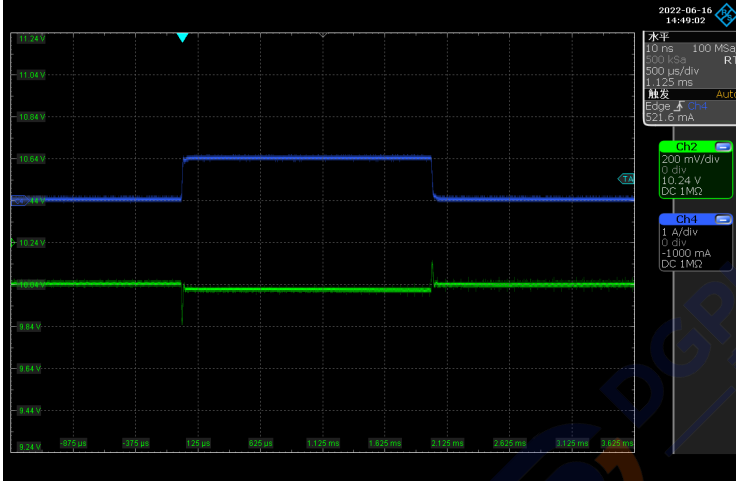

Short Circuit Protection (SCP)

$V_{OUT} = 10\text{V}$, $V_{IN} = 15\text{V}$, OUT short to GND, CH2: V_{OUT} , CH4: I_{OUT}

SCP Instant

SCP Release

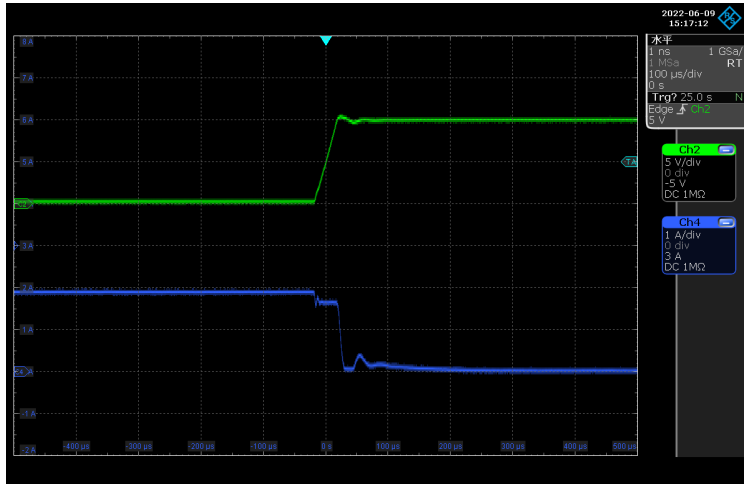
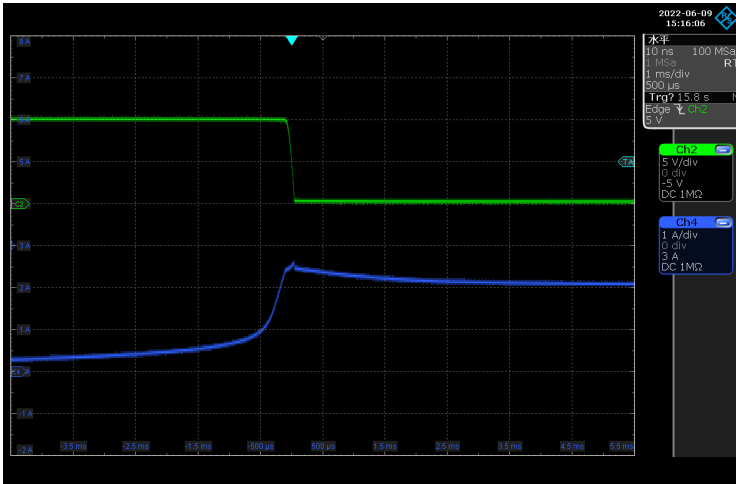

8 Detailed Description

8.1 Description

LM317C is a three terminal positive voltage regulator with adjustable output. By setting two peripheral resistors, the output voltage range of the device can be set from 1.2V to 37V, and the current up to 1.5A can be provided. LM317C integrates current limiting, thermal overload protection and safe operation area protection internally, and corresponding capacitors can be added to improve transient response. Therefore, the device is very easy to use, which is difficult to achieve with a standard three terminal regulator.

8.2 Representative Schematic Diagram

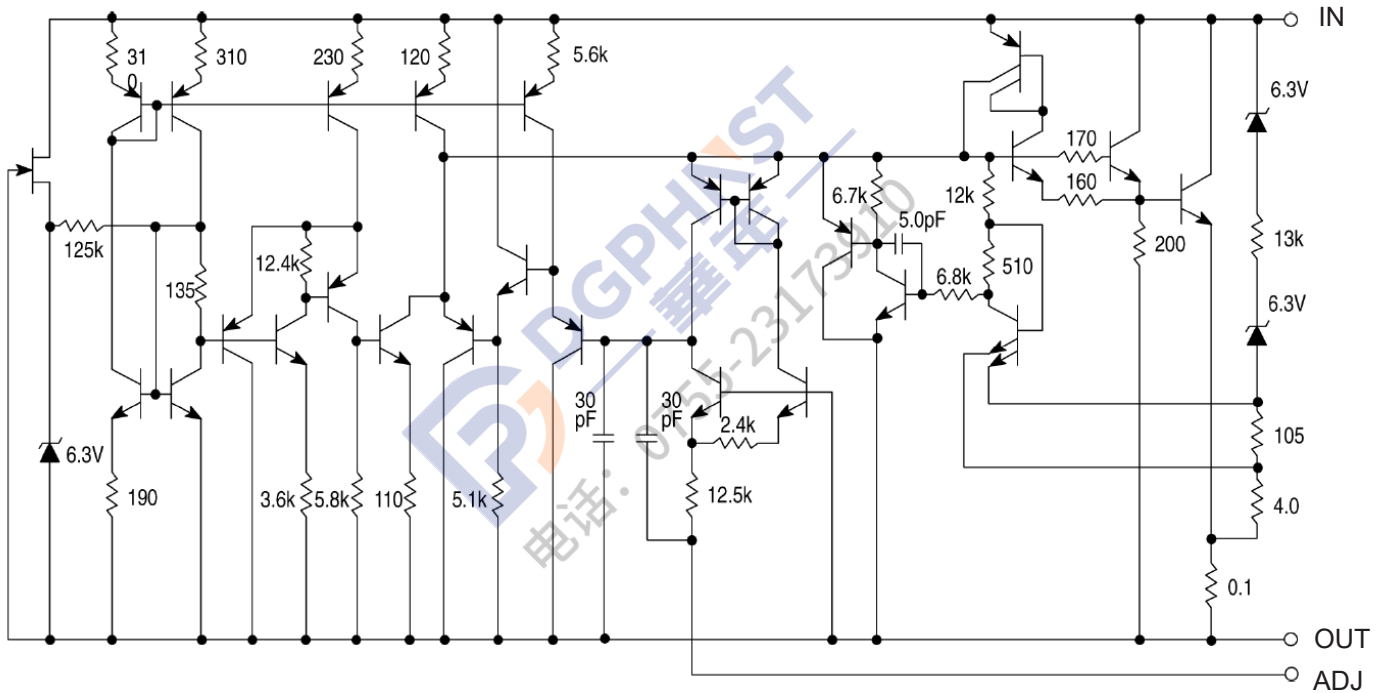

LM317C contains 29 transistors.

8.3 Feature Description

Comprehensive Overload Protection

LM317C is internally integrated with current limit and thermal shutdown protection. When the output current is large or the junction temperature is higher than the rated range of the data sheet to a certain extent, LM317C will enter the protection state and reduce the output to close to 0V to prevent accidental damage to the device. After the output current or junction temperature decreases to a certain extent, LM317C will be released from the protection state and output normally.

When OUT is short circuited to GND, LM317C will also enter the protection state and maintain the current at a low level. If the short circuit is removed, LM317C will also remove the protection status and output normally.

When the input voltage is more than 45V, the device may be damaged due to serious internal heating when the load current is more than 0.4A.

8 Detailed Description

8.3 Feature Description (continued)

Minimum Operating Current

LM317C needs to provide bias current between OUT and ADJ to make the device work normally. The load or feedback must consume this minimum current for regulation, otherwise the output may be too high. Refer to the *Electrical Characteristics* for the minimum load current required to maintain regulation.

Minimum Operating Voltage Difference

LM317C requires a voltage difference ($V_{IN} - V_{OUT}$) of at least 3V between input and output before it can operate in the normal working state, otherwise the device may not maintain the normal output state.

Programmable Feedback

The device will provide 1.25V (typical value) bias voltage between OUT and ADJ, and the output voltage or current (not both) can be easily programmed through external resistance. For current regulation applications, a single resistor with a resistance value of $(1.25V / I_{OUT})$ and a rated power greater than $((1.25V)^2 / R)$ shall be used. For voltage regulation applications, two resistors set the output voltage.

Normal Operation

LM317C is a three terminal positive voltage regulator with adjustable output. During normal operation, LM317C will maintain a reference voltage V_{REF} of 1.25V between OUT and ADJ. This reference voltage V_{REF} is converted from R_1 to programming current I_{PROG} (see Figure 8-1), which flows to ground through R_2 . The regulated output voltage is given by the following formula:

$$V_{OUT} = V_{REF} \times \left(1 + \frac{R_2}{R_1}\right) + I_{ADJ} \times R_2$$

As an error term in the formula, I_{ADJ} is designed to be less than 100 μ A and keep constant. Therefore, in most applications, this item can be negligible.

Since the LM317C requires the minimum operating current and the minimum operating voltage difference for normal operation, the corresponding conditions shall be met in the circuit design.

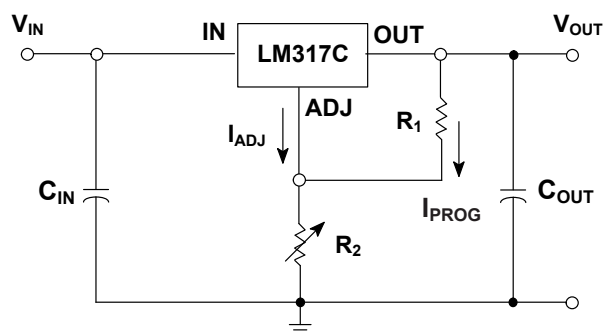

Figure 8-1. Basic Normal Operation

9 Application and Implementation

9.1 Application Information

Load Regulation

Following the following design recommendations can help LM317C achieve better load regulation. The switching resistor R_1 shall be connected as close to the voltage regulator as possible to minimize the voltage drop of the line effectively connected in series with the reference voltage and avoid poor adjustment rate. The grounding terminal of R_2 can be returned close to the load grounding terminal to provide remote grounding sampling and improve the load adjustment rate.

External Capacitors

A $0.1\mu\text{F}$ disc or $1.0\mu\text{F}$ tantalum input bypass capacitor (C_{IN}) is recommended to reduce the sensitivity to input line impedance. The adjustment terminal may be bypassed to ground to improve ripple rejection.

A C_{ADJ} of $10\mu\text{F}$ (between OUT and GND) is recommended to improve ripple rejection. It prevents amplification of the ripple as the output voltage is adjusted higher.

Although the LM317C is stable with no output capacitance, like any feedback circuit, certain values of external capacitance can cause excessive ringing. An output capacitance (C_{OUT}) in the form of a $1.0\mu\text{F}$ tantalum or $25\mu\text{F}$ aluminum electrolytic capacitor on the output swamps this effect and insures stability. The input capacitance (C_{IN}) and output capacitance (C_{OUT}) should be placed as close to the corresponding device pins as possible (C_{IN} for IN, C_{OUT} for OUT).

When the LM317C is used as a reference voltage source instead of a peripheral resistor, it is recommended to use an input capacitor of $1.0\mu\text{F}$ or more to obtain better voltage stability.

Protection Diodes

When external capacitors are used with any IC regulator it is sometimes necessary to add protection diodes to prevent the capacitors from discharging through low current points into the regulator. Figure 9-1 shows the LM317C with the recommended protection diodes for output voltages in excess of 25V or high capacitance values ($C_{\text{OUT}} > 25\mu\text{F}$, $C_{\text{ADJ}} > 10\mu\text{F}$). Diode D_1 prevents C_{OUT} from discharging through the IC during an input short circuit. Diode D_2 protects against capacitor C_{ADJ} discharging through the IC during an output short circuit. The combination of diodes D_1 and D_2 prevents C_{ADJ} from discharging through the IC during an input short circuit.

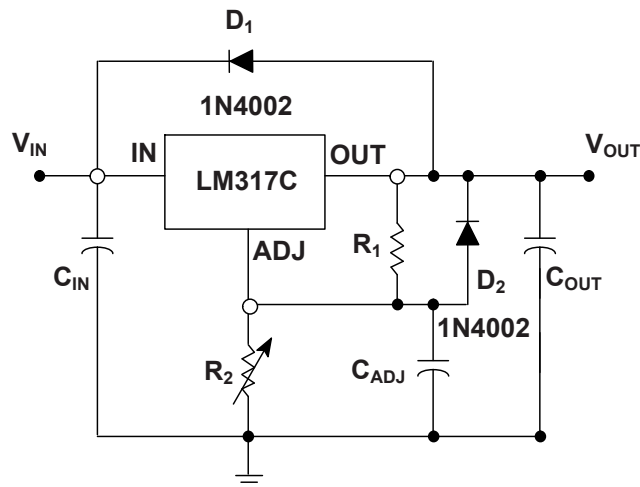

Figure 9-1. Voltage Regulator with Protection Diodes

9 Application and Implementation

9.2 System Example

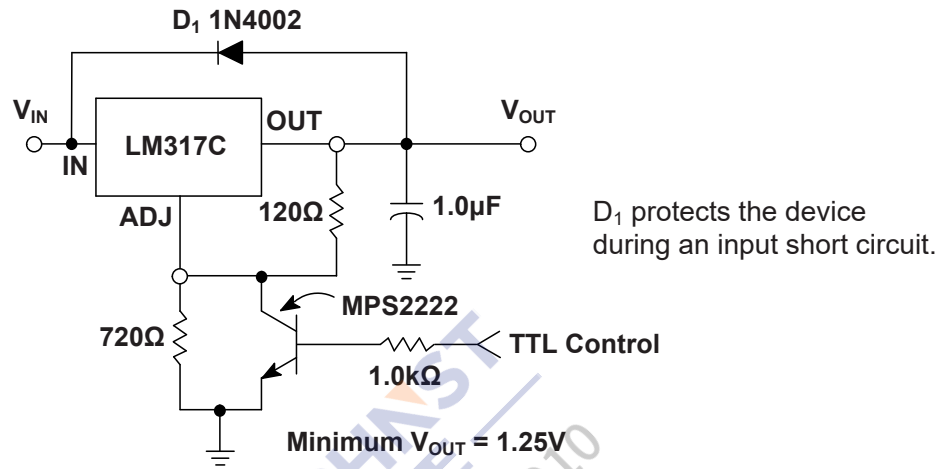

Figure 9-2. 5V Electronic Shutdown Regulator

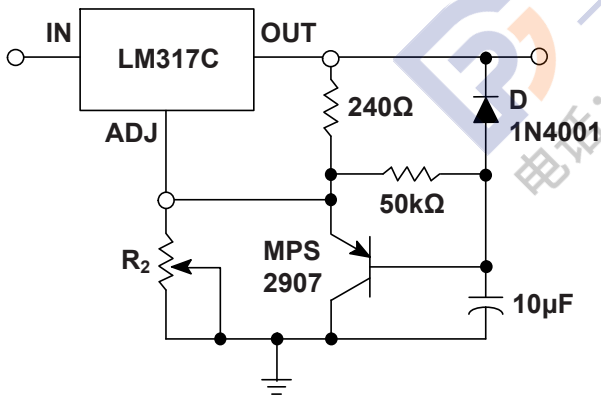

Figure 9-3. Slow Turn-On Regulator

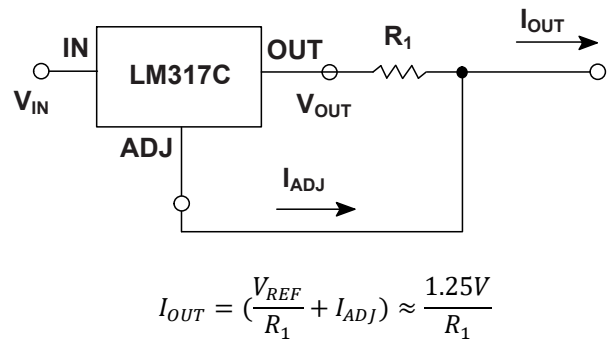

Figure 9-4. Current Regulator

$$I_{OUT} = \left(\frac{V_{REF}}{R_1} + I_{ADJ} \right) \approx \frac{1.25V}{R_1}$$

NOTE

The application information in this section is not part of the data sheet component specification, and JSCJ makes no commitment or statement to guarantee its accuracy or completeness. Customers are responsible for determining the rationality of corresponding components in their circuit design and making tests and verifications to ensure the normal realization of their circuit design.

10 Mechanical Information

10.1 SOT-223 Mechanical Information

SOT-223 Outline Dimensions

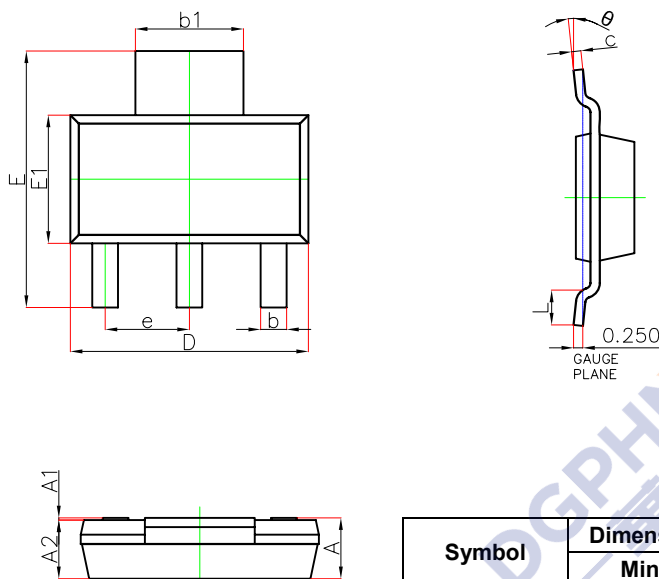

Symbol	Dimensions In Millimeters		Dimensions In Inches	
	Min.	Max.	Min.	Max.
A	—	1.800	—	0.071
A1	0.020	0.100	0.001	0.004
A2	1.500	1.700	0.059	0.067
b	0.660	0.840	0.026	0.033
b1	2.900	3.100	0.114	0.122
c	0.230	0.350	0.009	0.014
D	6.300	6.700	0.248	0.264
E	6.700	7.300	0.264	0.287
E1	3.300	3.700	0.130	0.146
e	2.300(BSC)		0.091(BSC)	
L	0.750	—	0.030	—
θ	0°	10°	0°	10°

SOT-223 Suggested Pad Layout

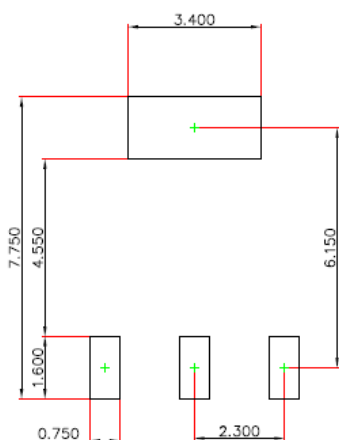

Note:

1. Controlling dimension: in millimeters.
2. General tolerance: ±0.05mm.
3. The pad layout is for reference purposes only.

10 Mechanical Information

10.2 TO-220-3L Mechanical Information

TO-220-3L Outline Dimensions

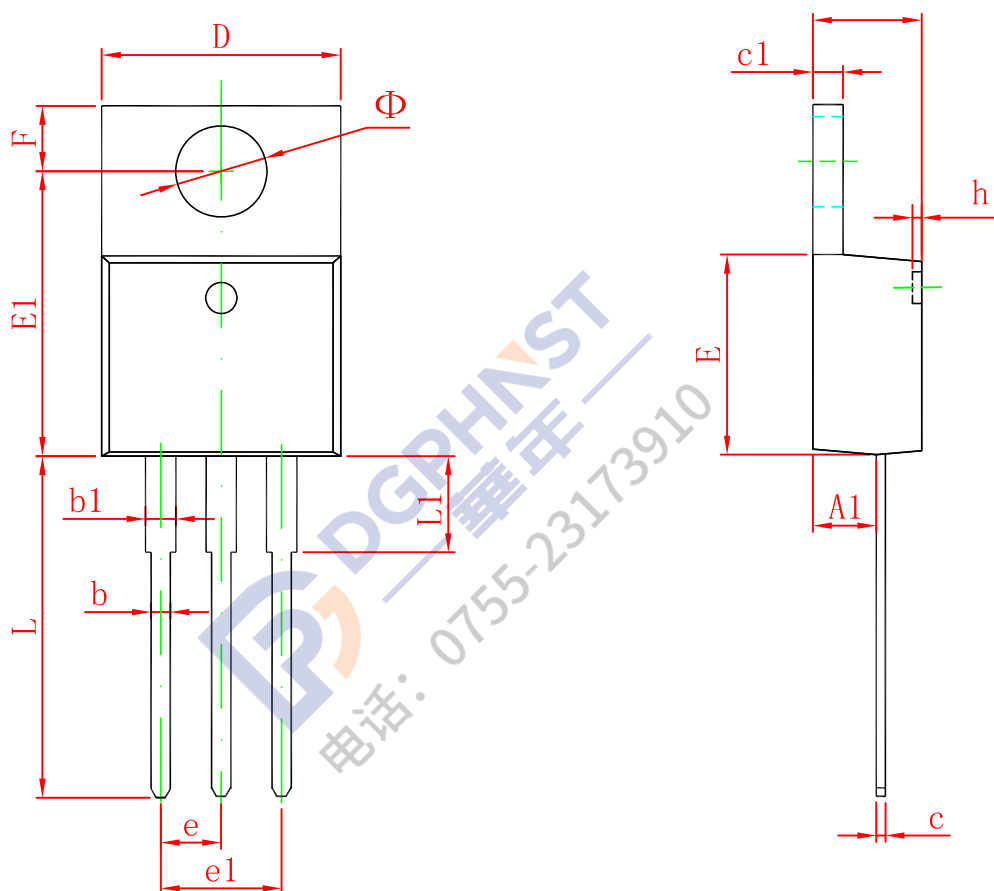

Symbol	Dimensions In Millimeters		Dimensions In Inches	
	Min	Max	Min	Max
A	4.470	4.670	0.176	0.184
A1	2.520	2.820	0.099	0.111
b	0.710	0.910	0.028	0.036
b1	1.170	1.370	0.046	0.054
c	0.310	0.530	0.012	0.021
c1	1.170	1.370	0.046	0.054
D	10.010	10.310	0.394	0.406
E	8.500	8.900	0.335	0.350
E1	12.060	12.460	0.475	0.491
e	2.540 TYP		0.100 TYP	
e1	4.980	5.180	0.196	0.204
F	2.590	2.890	0.102	0.114
h	0.000	0.300	0.000	0.012
L	13.400	13.800	0.528	0.543
L1	3.560	3.960	0.140	0.156
Φ	3.735	3.935	0.147	0.155

10 Mechanical Information

10.3 TO-252-2L Mechanical Information

TO-252-2L Outline Dimensions

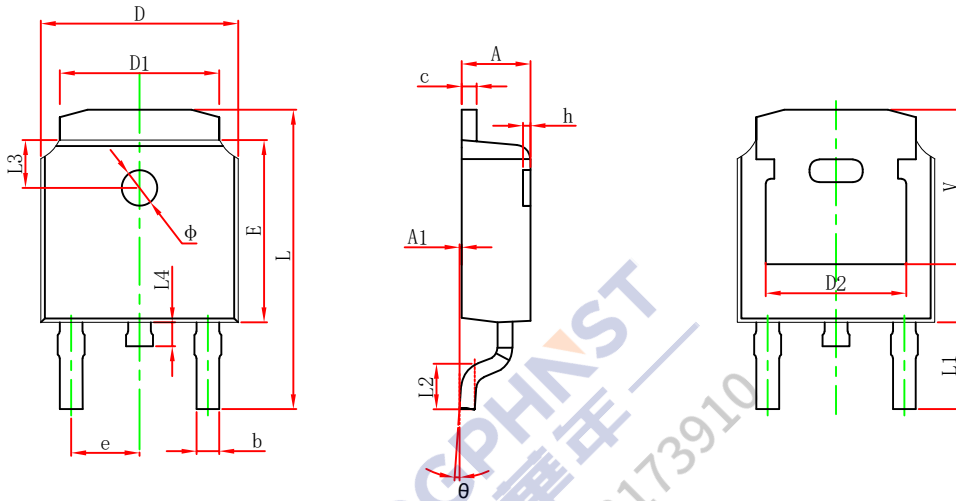

Symbol	Dimensions In Millimeters		Dimensions In Inches	
	Min.	Max.	Min.	Max.
A	2.200	2.400	0.087	0.094
A1	0.000	0.127	0.000	0.005
b	0.635	0.770	0.025	0.030
c	0.460	0.580	0.018	0.023
D	6.500	6.700	0.256	0.264
D1	5.100	5.460	0.201	0.215
D2	4.830 REF.		0.190 REF.	
E	6.000	6.200	0.236	0.244
e	2.186	2.386	0.086	0.094
L	9.712	10.312	0.382	0.406
L1	2.900 REF.		0.114 REF.	
L2	1.400	1.700	0.055	0.067
L3	1.600 REF.		0.063 REF.	
L4	0.600	1.000	0.024	0.039
Φ	1.100	1.300	0.043	0.051
θ	0°	8°	0°	8°
h	0.000	0.300	0.000	0.012
V	5.250 REF.		0.207 REF.	

TO-252-2L Suggest Pad Layout

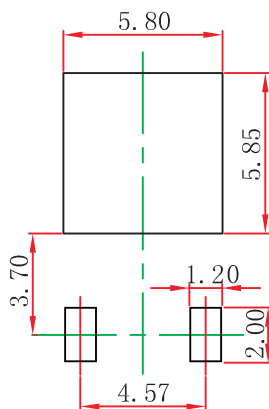

Note:

1. Controlling dimension: in millimeters.
2. General tolerance: ±0.05mm.
3. The pad layout is for reference purposes only.

10 Mechanical Information

10.4 TO-263-2L Mechanical Information

TO-263-2L Outline Dimensions

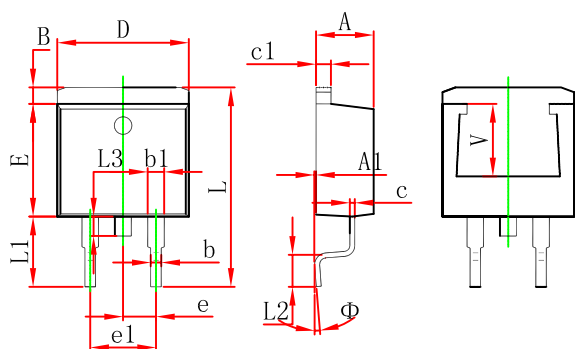

Symbol	Dimensions In Millimeters		Dimensions In Inches	
	Min.	Max.	Min.	Max.
A	4.470	4.670	0.176	0.184
A1	0.000	0.150	0.000	0.006
B	1.120	1.420	0.044	0.056
b	0.710	0.910	0.028	0.036
b1	1.170	1.370	0.046	0.054
c	0.310	0.530	0.012	0.021
c1	1.170	1.370	0.046	0.054
D	10.010	10.310	0.394	0.406
E	8.500	8.900	0.335	0.350
e	2.540 TYP.		0.100 TYP.	
e1	4.980	5.180	0.196	0.204
L	14.940	15.500	0.588	0.610
L1	4.950	5.450	0.195	0.215
L2	2.340	2.740	0.092	0.108
L3	1.300	1.700	0.051	0.067
Φ	0°	8°	0°	8°
V	5.600 REF.		0.220 REF.	

TO-263-2L Suggest Pad Layout

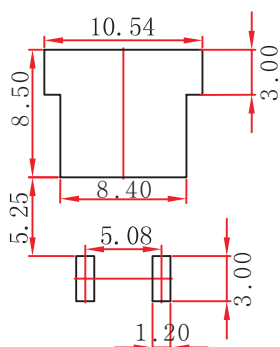

Note:

1. Controlling dimension: in millimeters.
2. General tolerance: ±0.05mm.
3. The pad layout is for reference purposes only.

11 Packaging Information

11.1 SOT-223 Tape and Reel Information

SOT-223 Embossed Carrier Tape

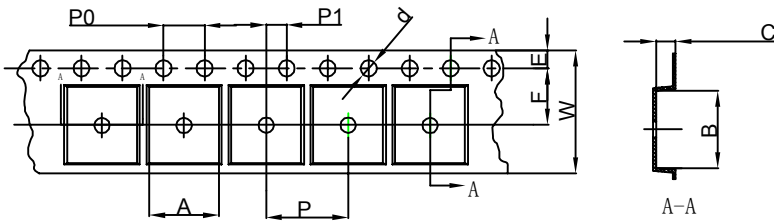

Packaging Description:
 SOT-223 parts are shipped in tape. The carrier tape is made from a dissipative (carbon filled) polycarbonate resin. The cover tape is a multilayer film (Heat Activated Adhesive in nature) primarily composed of polyester film, adhesive layer, sealant, and anti-static sprayed agent. These reeled parts in standard option are shipped with 2,500 units per 13" or 33.0cm diameter reel. The reels are clear in color and is made of polystyrene plastic (anti-static coated).

Dimensions are in millimeter											
Pkg type	A	B	C	d	E	F	P0	P	P1	W	
SOT-223	6.765	7.335	1.88	Ø1.50	1.75	5.50	4.00	8.00	2.00	12.00	

SOT-223 Tape Leader and Trailer

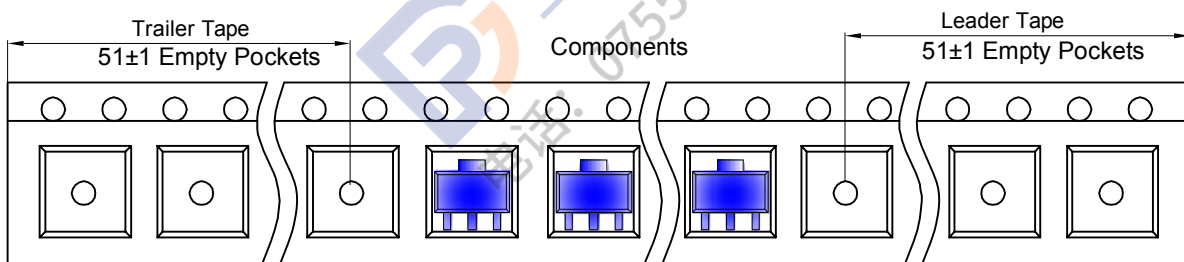

SOT-223 Reel

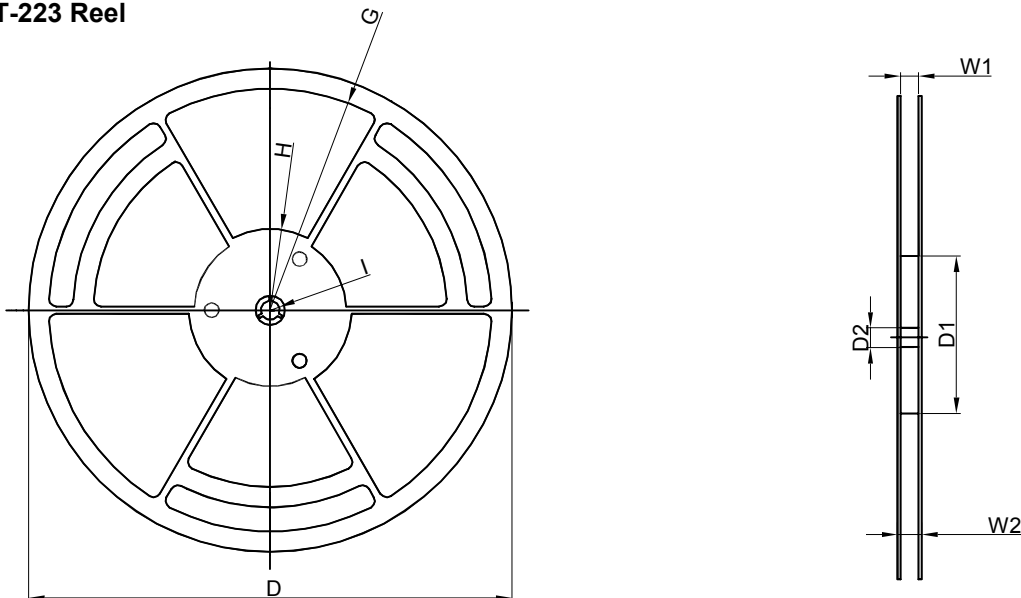

Dimensions are in millimeter									
Reel Option	D	D1	D2	G	H	I	W1	W2	
13" Dia	Ø330.00	100.00	13.00	R151.00	R56.00	R6.50	12.40	17.60	

REEL	Reel Size	Box	Box Size(mm)	Carton	Carton Size(mm)	G.W.(kg)
2,500 pcs	13 inch	2,500 pcs	336×336×48	20,000 pcs	445×355×365	

11 Packaging Information

11.2 TO-252-2L Tape and Reel Information

TO-252-2L Embossed Carrier Tape

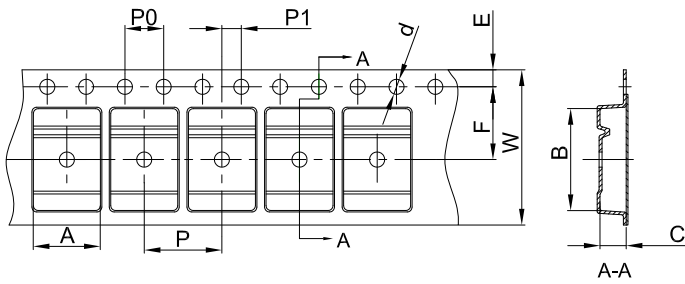

Packaging Description:
 TO-252 parts are shipped in tape. The carrier tape is made from a dissipative (carbon filled) polycarbonate resin. The cover tape is a multilayer film (Heat Activated Adhesive in nature) primarily composed of polyester film, adhesive layer, sealant, and anti-static sprayed agent. These reeled parts in standard option are shipped with 25,00 units per 13" or 33.0 cm diameter reel. The reels are clear in color and is made of polystyrene plastic (anti-static coated).

Dimensions are in millimeter										
Pkg type	A	B	C	d	E	F	P0	P	P1	W
TO-252	6.90	10.50	2.70	Ø1.55	1.75	7.50	4.00	8.00	2.00	16.00

TO-252-2L Tape Leader and Trailer

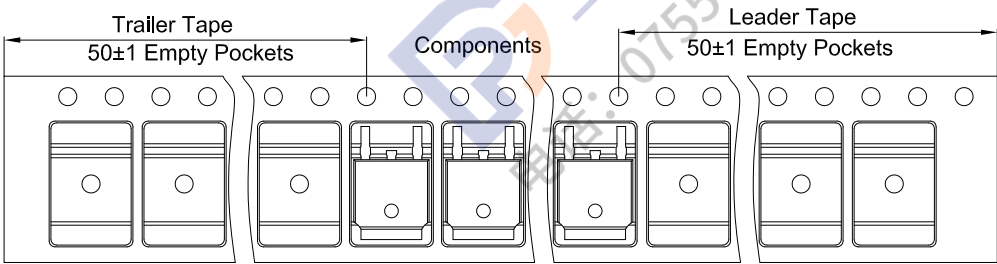

TO-252-2L Reel

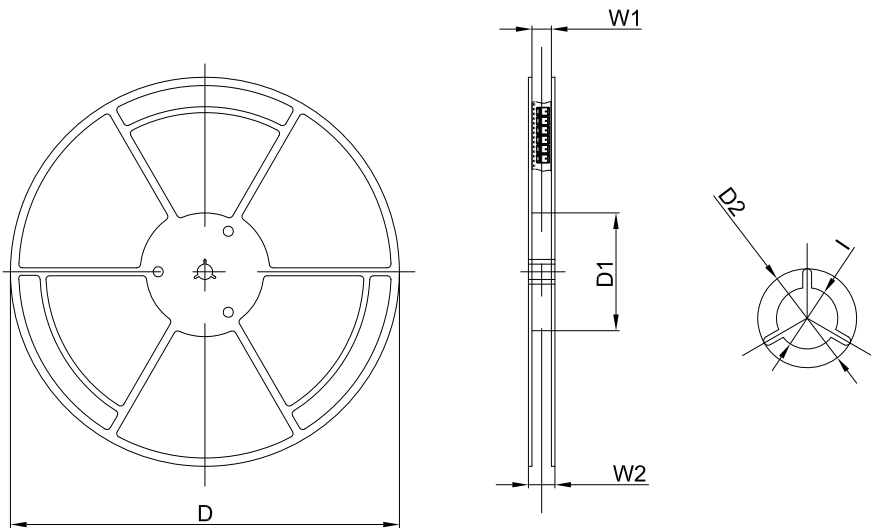

Dimensions are in millimeter						
Reel Option	D	D1	D2	W1	W2	I
13" Dia	330.00	100.00	Ø21.00	16.40	21.00	Ø13.00

REEL	Reel Size	Box	Box Size(mm)	Carton	Carton Size(mm)	G.W.(kg)
2,500 pcs	13inch	2,500 pcs	340×336×29	25,000 pcs	353×346×365	

11 Packaging Information

11.3 TO-263-2L Tape and Reel Information

TO-263-2L Embossed Carrier Tape

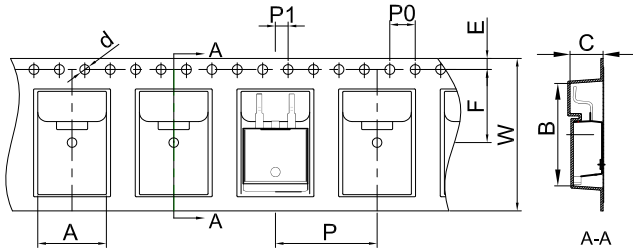

Packaging Description:
 TO-263-2L parts are shipped in tape. The carrier tape is made from a dissipative (carbon filled) polycarbonate resin. The cover tape is a multilayer film (Heat Activated Adhesive in nature) primarily composed of polyester film, adhesive layer, sealant, and anti-static sprayed agent. These reeled parts in standard option are shipped with 800 units per 13" or 33.0 cm diameter reel. The reels are clear in color and is made of polystyrene plastic (anti-static coated).

Dimensions are in millimeter										
Pkg type	A	B	C	d	E	F	P0	P	P1	W
TO-263-2L	10.80	16.13	5.21	Ø1.55	1.75	11.50	4.00	16.00	2.00	24.00

TO-263-2L Tape Leader and Trailer

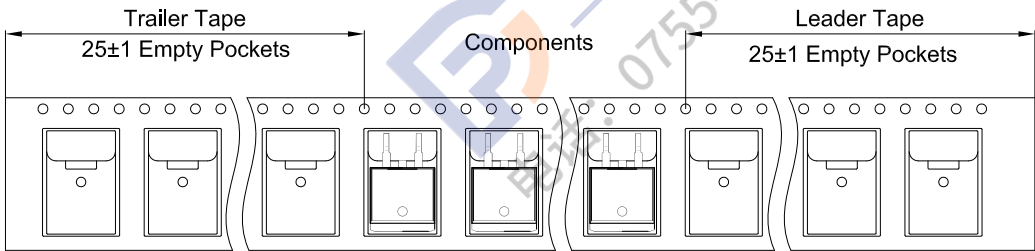

TO-263-2L Reel

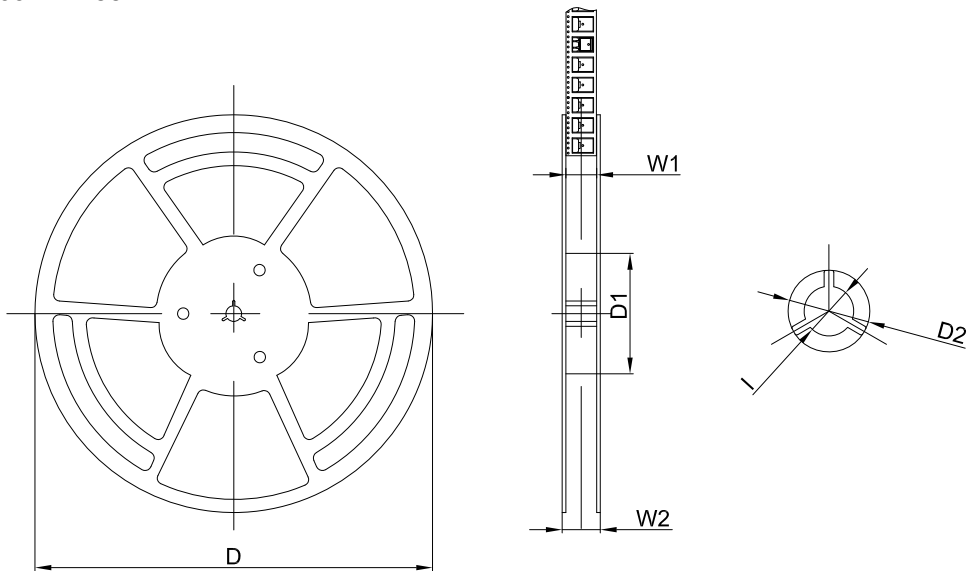

Dimensions are in millimeter						
Reel Option	D	D1	D2	W1	W2	I
13"Dia	Ø330.00	100.00	Ø21.00	24.4	30.4	Ø13.00

REEL	Reel Size	Box	Box Size(mm)	Carton	Carton Size(mm)	G.W.(kg)
800 pcs	13 inch	800 pcs	340×336×36	8,000 pcs	400×353×365	

12 Notes and Revision History

12.1 Associated Product Family and Others

To view other products of the same type or IC products of other types, click the official website of JSCJ <https://www.jscj-elec.com> for more details.

12.2 Notes

Electrostatic Discharge Caution



This IC may be damaged by ESD. Relevant personnel shall comply with correct installation and use specifications to avoid ESD damage to the IC. If appropriate measures are not taken to prevent ESD damage, the hazards caused by ESD include but are not limited to degradation of integrated circuit performance or complete damage of integrated circuit. For some precision integrated circuits, a very small parameter change may cause the whole device to be inconsistent with its published specifications.

Junction-to-ambient Thermal Resistance $R_{\theta JA}$

Definition: The junction to ambient thermal resistance $R_{\theta JA}$ is a metric of the thermal performance of the device's packages. By comparing the metric of different companies on the same product package, the thermal performance of the product can be roughly estimated in a relative sense. $R_{\theta JA}$ is measured under the conditions specified in the corresponding specifications. If the measurement of $R_{\theta JA}$ of two products follows different specifications and standards, or although the same specifications and standards are adopted, it is not tested in strict accordance with the specifications, then the $R_{\theta JA}$ of two products will lose the meaning of comparison. This product follows the test specified by JEDEC in the EIA/JESD51-x series documents. $R_{\theta JA}$ is measured in still air with $T_A = 25^\circ\text{C}$ and installed on a 1 in 2 FR-4 board covered with 2 ounces of copper.

Usage: Junction to ambient thermal resistance $R_{\theta JA}$ is a parameter defined at the system level rather than on a single device or chip. In the test of $R_{\theta JA}$ provided in the data sheet, most of the heat generated by the operation of the device is dissipated through the test board rather than the packaging surface of the device. In fact, the design and layout of PCB (such as chip or pad size, internal package geometry, etc.) will significantly affect $R_{\theta JA}$. At this time, any calculation of the junction temperature or thermal power consumption of the device by applying $R_{\theta JA}$ in the data sheet will have a very large error, so that it does not match the real performance of the device.

Therefore, $R_{\theta JA}$ should be used as the relative comparison of product packaging thermal performance between different companies, rather than directly using $R_{\theta JA}$ in the data sheet in the actual calculation.

Reference Maximum Power Dissipation for Continuous Operation $P_{D\text{Ref}}$

The reference maximum power dissipation for continuous operation $P_{D\text{Ref}}$ is not an accurate value obtained from the actual test. It is a theoretical value obtained according to the heat dissipation capacity of packaging combined with practical application. It is used to compare the differences of heat dissipation capacity more intuitively between products of different companies. This value is only for estimation reference and cannot be used as an index of the actual performance of the device for circuit design.

12 Notes and Revision History

12.3 Revision History

February, 2023: changed from rev - 1.1 to rev - 1.2:

- Page 5, Thermal Information, added junction-to-case thermal resistance $R_{\theta JC}$.

August 2022: changed from rev - 1.0 to rev - 1.1:

- Modified data sheet format: All data sheet, added headers, changed font size;
- Page 1, modified footer;
- Page 1, Introduction, Features, output voltage range changed from 1.25V to 1.2V;
- Page 2, Orderable Information, changed Max OP T_J : 125°C to OP T_J : -40 to 125°C;
- Page 4, Recommended Operating Conditions, changed OP T_J from 0 to 125°C to -40 to 125°C;
- Page 4, Absolute Maximum Ratings, Recommended Operating Conditions, changed OP T_J from 0 to 125°C to -40 to 125°C;
- Page 24, DISCLAIMER, deleted the description of "automotive electronics".

June 2022: released LM317C rev - 1.0.



DISCLAIMER

IMPORTANT NOTICE, PLEASE READ CAREFULLY

The information in this data sheet is intended to describe the operation and characteristics of our products. JSCJ has the right to make any modification, enhancement, improvement, correction or other changes to any content in this data sheet, including but not limited to specification parameters, circuit design and application information, without prior notice.

Any person who purchases or uses JSCJ products for design shall: 1. Select products suitable for circuit application and design; 2. Design, verify and test the rationality of circuit design; 3. Procedures to ensure that the design complies with relevant laws and regulations and the requirements of such laws and regulations. JSCJ makes no warranty or representation as to the accuracy or completeness of the information contained in this data sheet and assumes no responsibility for the application or use of any of the products described in this data sheet.

Without the written consent of JSCJ, this product shall not be used in occasions requiring high quality or high reliability, including but not limited to the following occasions: medical equipment, military facilities and aerospace. JSCJ shall not be responsible for casualties or property losses caused by abnormal use or application of this product.

Official Website: www.jscj-elec.com

Copyright © JIANGSU CHANGJING ELECTRONICS TECHNOLOGY CO., LTD.