

## LMV358

### DESCRIPTION

The LMV358(dual) are rail-to-rail input and output voltage feedback amplifiers offering low cost. They have a wide input common mode voltage range and output swing, and take the minimum operating supply voltage down to 2.1V and the maximum recommended supply voltage is 5.5V.

The LMV358 provide 1MHz bandwidth at a low current consumption of 60 $\mu$ A per amplifier. Very low input bias currents of 10pA enable LMV358 to be used for integrators, photodiode amplifiers, and piezoelectric sensors. Rail-to-rail inputs and outputs are useful to designers buffering ASIC in single-supply systems. Applications for the series amplifiers include safety monitoring, portable equipment, battery and power supply control, and signal conditioning and interfacing for transducers in very low power systems.

The LMV358 is available in SOP8 and MSOP8 packages.

### Features

- Low Cost
- Rail-to-Rail Input and Output 0.8mV Typical VOS
- Unity Gain Stable
- Gain Bandwidth Product: 1MHz
- Very Low Input Bias Currents:
- Operates on 2.1V to 5.5V Supplies
- Input Voltage Range: -0.1V to +5.6V with  $V_S = 5.5V$
- Low Supply Current: < 60 $\mu$ A/Amplifier
- Small Packaging: LMV358 Available in SOP8, MSOP8

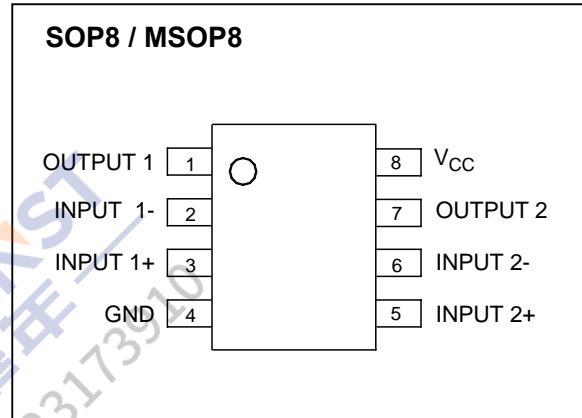

### Applications

- ASIC Input or Output Amplifier
- Sensor Interface
- Piezo Electric Transducer Amplifier
- Medical Instrumentation
- Mobile Communication
- Audio Output
- Portable Systems
- Smoke Detectors
- Notebook PC
- PCMCIA Cards
- Battery – Powered Equipment
- DSP Interface

## LMV358 ELECTRICAL CHARACTERISTICS

### ABSOLUTE MAXIMUM RATINGS

Supply Voltage, V+ to V-.....	7.5V
Common-Mode Input Voltage.....	(-V <sub>S</sub> ) - 0.5V to (+V <sub>S</sub> ) + 0.5V
Storage Temperature Range.....	-65°C to +150°C
Junction Temperature.....	160°C
Operating Temperature Range.....	-40°C to +85°C
Lead Temperature Range (Soldering 10 sec).....	260°C

(At R<sub>L</sub> = 100KΩ connected to V<sub>S</sub>/2, and V<sub>OUT</sub> = V<sub>S</sub>/2, V<sub>S</sub>=+5V, unless otherwise noted.)

PARAMETER	CONDITIONS	LMV358				
		TYP	MIN/MAX OVER TEMPERATURE			
		+25°C	+25°C	0°C to 75°C	UNITS	MIN/MAX
<b>INPUT CHARACTERISTICS</b>						
Input Offset Voltage (V <sub>OS</sub> )		±0.8	±5	±6	mV	MAX
Input Bias Current (I <sub>B</sub> )		10			pA	TYP
Input Offset Current (I <sub>OS</sub> )		10			pA	TYP
Common-Mode Voltage Range (V <sub>CM</sub> )	V <sub>S</sub> =5.5V	-0.1to+5.6			V	TYP
Common-Mode Rejection Ratio (CMRR)	V <sub>S</sub> =5.5V, V <sub>CM</sub> =-0.1V to 4V	70	62	62	dB	MIN
	V <sub>S</sub> = 5.5V, V <sub>CM</sub> =-0.1V to 5.6V	68	56	55	dB	MIN
Open-Loop Voltage Gain (AOL)	R <sub>L</sub> = 5KΩ, V <sub>o</sub> =0.1V to 4.9V	80	70	70	dB	MIN
	R <sub>L</sub> =100KΩ, V <sub>o</sub> =0.035V to 4.965V	84	80	80	dB	MIN
<b>OUTPUT CHARACTERISTICS</b>						
Output Voltage Swing from Rail	R <sub>L</sub> = 100KΩ	0.008			V	TYP
Output Current (I <sub>OUT</sub> )	R <sub>L</sub> = 10KΩ	0.08			V	TYP
		27	20	18.8	mA	MIN
<b>POWER SUPPLY</b>						
Operating Voltage Range			2.1	2.5	V	MIN
			5.5	5.5	V	MAX
Power Supply Rejection Ratio (PSRR)	V <sub>S</sub> =+2.5V to + 5.5V V <sub>CM</sub> = (-V <sub>S</sub> ) + 0.5V	82	60	58	dB	MIN
Quiescent Current / Amplifier (I <sub>Q</sub> )	I <sub>OUT</sub> = 0	60	80	86	μA	MAX
<b>DYNAMIC PERFORMANCE</b>						
Gain-Bandwidth Product (GBP)	C <sub>L</sub> = 100pF	1			MHz	TYP
Slew Rate (SR)	G = +1, 2V Output Step	0.52			V/μs	TYP
Settling Time to 0.1% (t <sub>S</sub> )	G = +1, 2V Output Step	5.3			μs	TYP
Overload Recovery Time	V <sub>IN</sub> ·Gain = V <sub>S</sub>	2.6			μs	TYP
<b>NOISE PERFORMANCE</b>						
Voltage Noise Density (e <sub>n</sub> )	f = 1kHz	27			n√Hz	TYP
	f = 10kHz	20			n√Hz	TYP

## TYPICAL PERFORMANCE CHARACTERISTICS

At  $T_A = +25^\circ\text{C}$ ,  $V_S = +5\text{V}$ , and  $R_L = 100\text{K}\Omega$  connected to  $V_S/2$ , unless otherwise noted.

Small-Signal Step Response

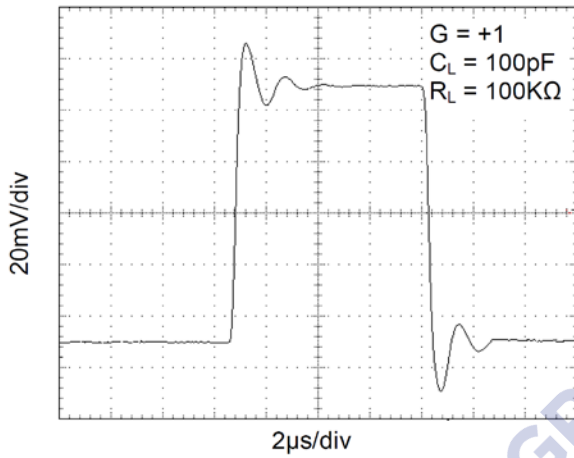

Large-Signal Step Response

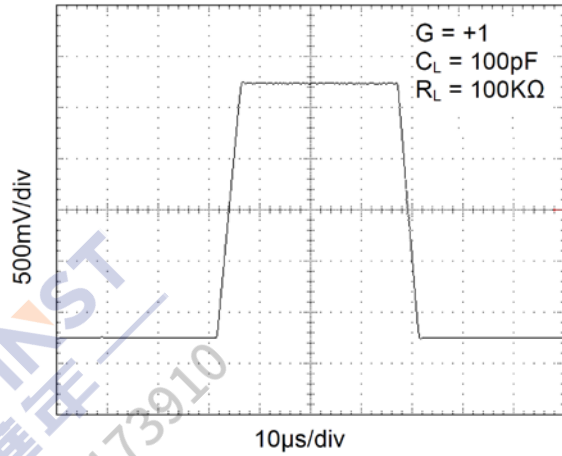

Small-Signal Overshoot vs. Load Capacitance

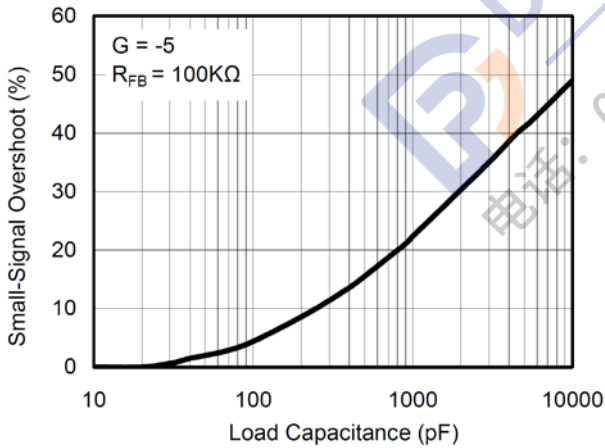

Small-Signal Overshoot vs. Load Capacitance

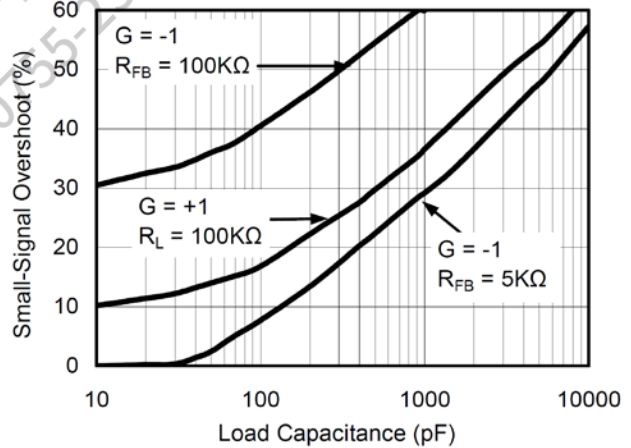

Maximum Output Voltage vs. Frequency

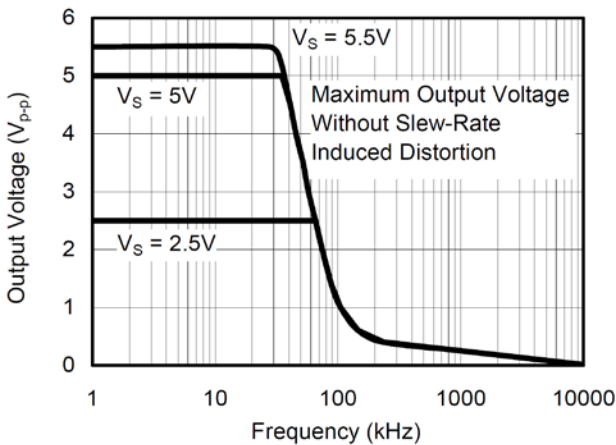

Quiescent and Short-Circuit Current vs. Supply Voltage

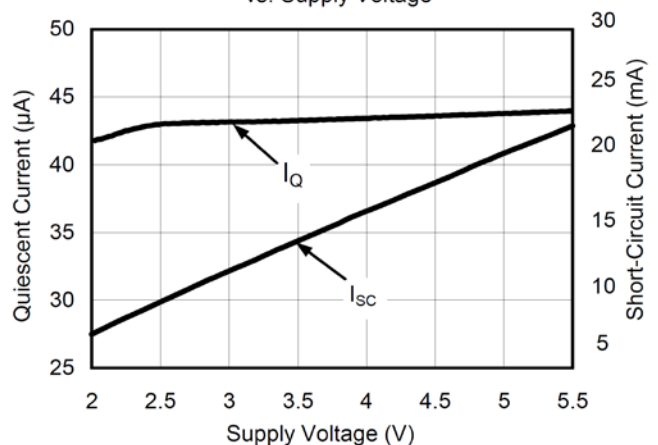

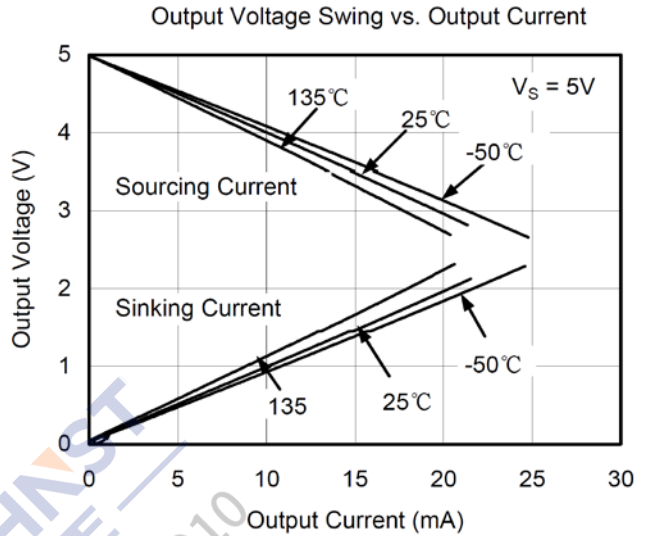
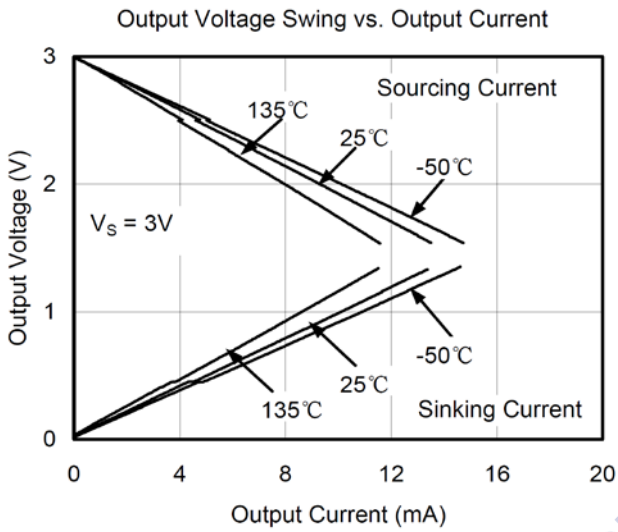

## TYPICAL PERFORMANCE CHARACTERISTICS

At  $T_A = +25^\circ\text{C}$ ,  $V_S = +5V$ , and  $R_L = 100\text{k}\Omega$  connected to  $V_S/2$ , unless otherwise noted.

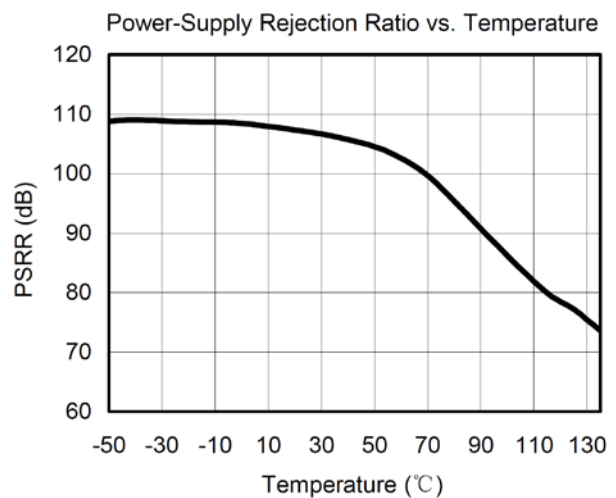
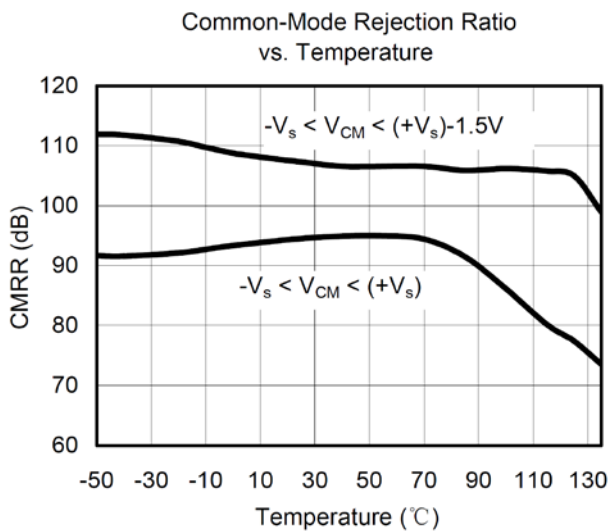
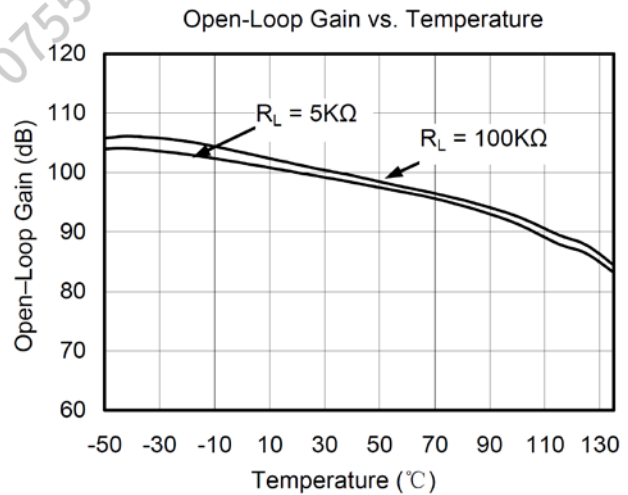
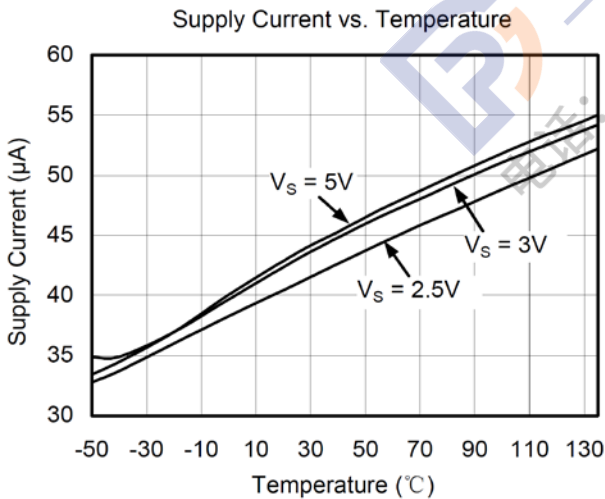

## APPLICATION NOTES

### Driving Capacitive Loads

The LMV358 can directly drive 250pF in unity-gain without oscillation. The unity-gain follower (buffer) is the most sensitive configuration to capacitive loading. Direct capacitive loading reduces the phase margin of amplifiers and this results in ringing or even oscillation. Applications that require greater capacitive drive capability should use an isolation resistor between the output and the capacitive load like the circuit in Figure 1. The isolation resistor  $R_{ISO}$  and the load capacitor  $C_L$  form a zero to increase stability. The bigger the  $R_{ISO}$  resistor value, the more stable  $V_{OUT}$  will be. Note that this method results in a loss of gain accuracy because  $R_{ISO}$  forms a voltage divider with the  $R_{LOAD}$ .

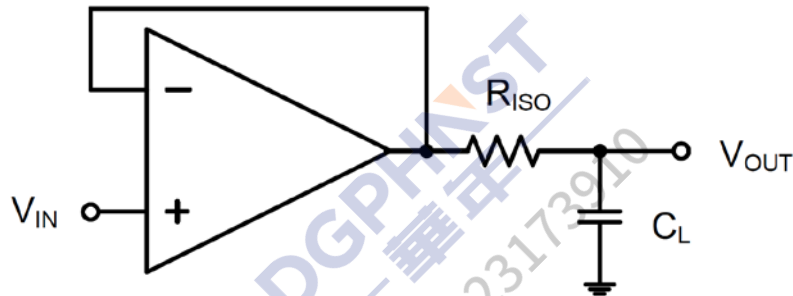

Figure 1. Indirectly Driving Heavy Capacitive Load

An improvement circuit is shown in Figure 2, It provides DC accuracy as well as AC stability.  $R_F$  provides the DC accuracy by connecting the inverting signal with the output,  $C_F$  and  $R_{ISO}$  serve to counteract the loss of phase margin by feeding the high frequency component of the output signal back to the amplifier's inverting input, thereby preserving phase margin in the overall feedback loop.

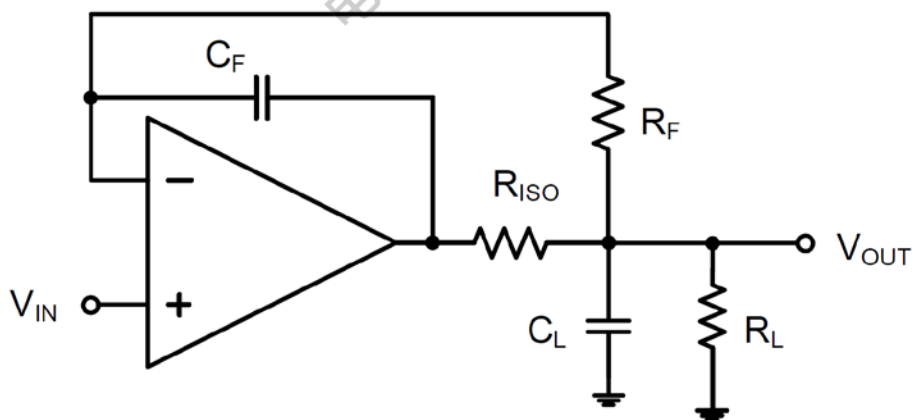

Figure 2. Indirectly Driving Heavy Capacitive Load with DC Accuracy

For no-buffer configuration, there are two other ways to increase the phase margin: (a) by increasing the amplifier's gain or (b) by placing a capacitor in parallel with the feedback resistor to counteract the parasitic capacitance associated with inverting node.

**Power-Supply Bypassing and Layout**

The LMV358 family operates from either a single +2.5V to +5.5V supply or dual  $\pm 1.25V$  to  $\pm 2.75V$  supplies. For single-supply operation, bypass the power supply VDD with a 0.1 $\mu F$  ceramic capacitor which should be placed close to the VDD pin. For dual-supply operation, both the VDD and the VSS supplies should be bypassed to ground with separate 0.1 $\mu F$  ceramic capacitors. 2.2 $\mu F$  tantalum capacitor can be added for better performance.

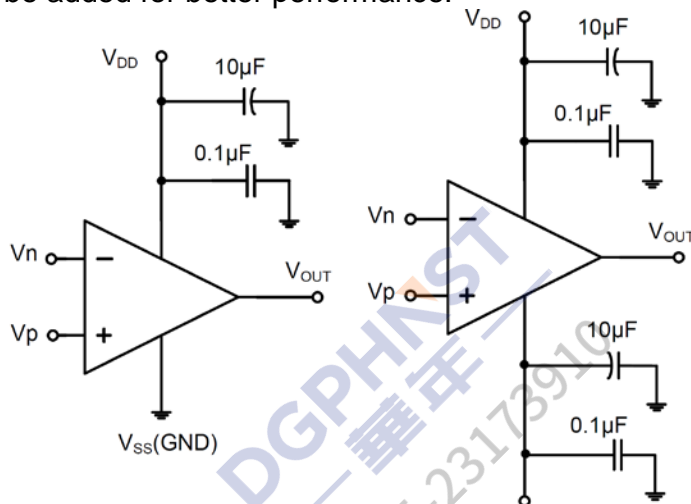

Figure 3. Amplifier with Bypass Capacitors

**TYPICAL APPLICATION CIRCUITS**

**Differential Amplifier**

The circuit shown in Figure 4 performs the difference function. If the resistors ratios are equal ( $R4 / R3 = R2 / R1$ ), then  $V_{OUT} = (V_p - V_n) \times R2 / R1 + V_{REF}$ .

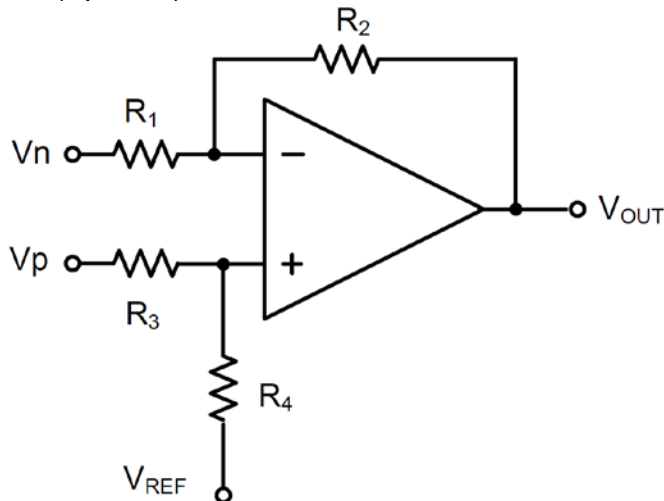

Figure 4. Differential Amplifier

### Instrumentation Amplifier

The circuit in Figure 5 performs the same function as that in Figure 4 but with the high input impedance.

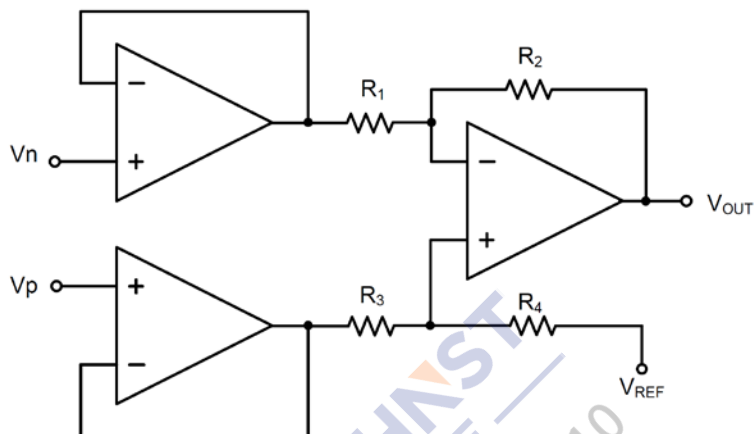

Figure 5. Instrumentation Amplifier

### Low Pass Active Filter

The low pass filter shown in Figure 6 has a DC gain of  $(-R_2 / R_1)$  and the  $-3\text{dB}$  corner frequency is  $1/2\pi R_2 C$ . Make sure the filter is within the bandwidth of the amplifier. The Large values of feedback resistors can couple with parasitic capacitance and cause undesired effects such as ringing or oscillation in high-speed amplifiers. Keep resistors value as low as possible and consistent with output loading consideration.

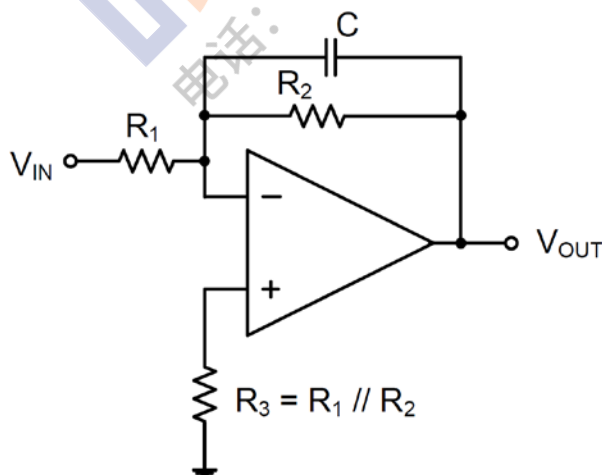
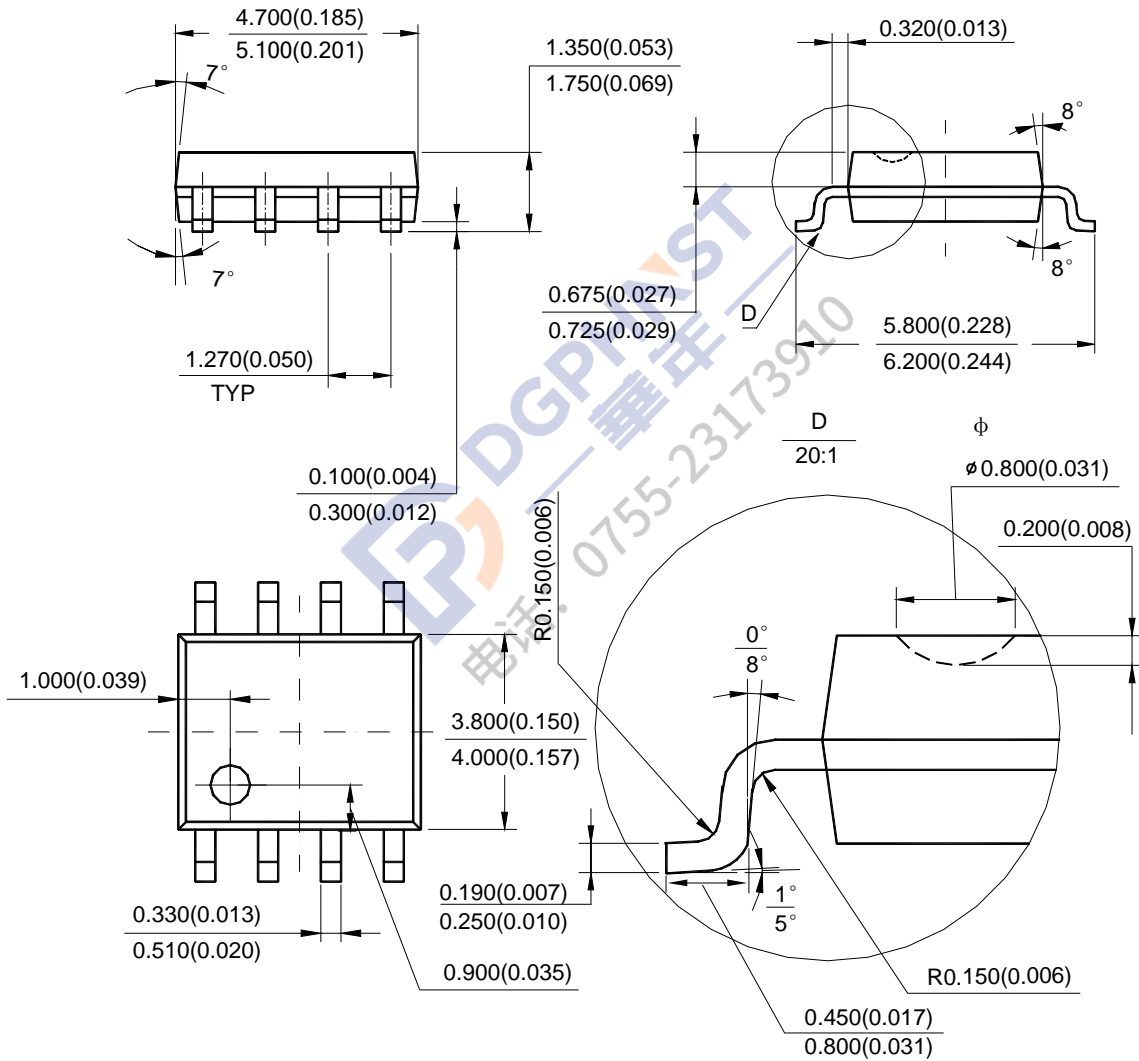

Figure 6. Low Pass Active Filter

# SOP8 Package Outline Dimensions

Unit: mm(inch)



Note: Eject hole, oriented hole and mold mark is optional.



# MSOP8 Package Outline Dimensions

Unit: mm(inch)

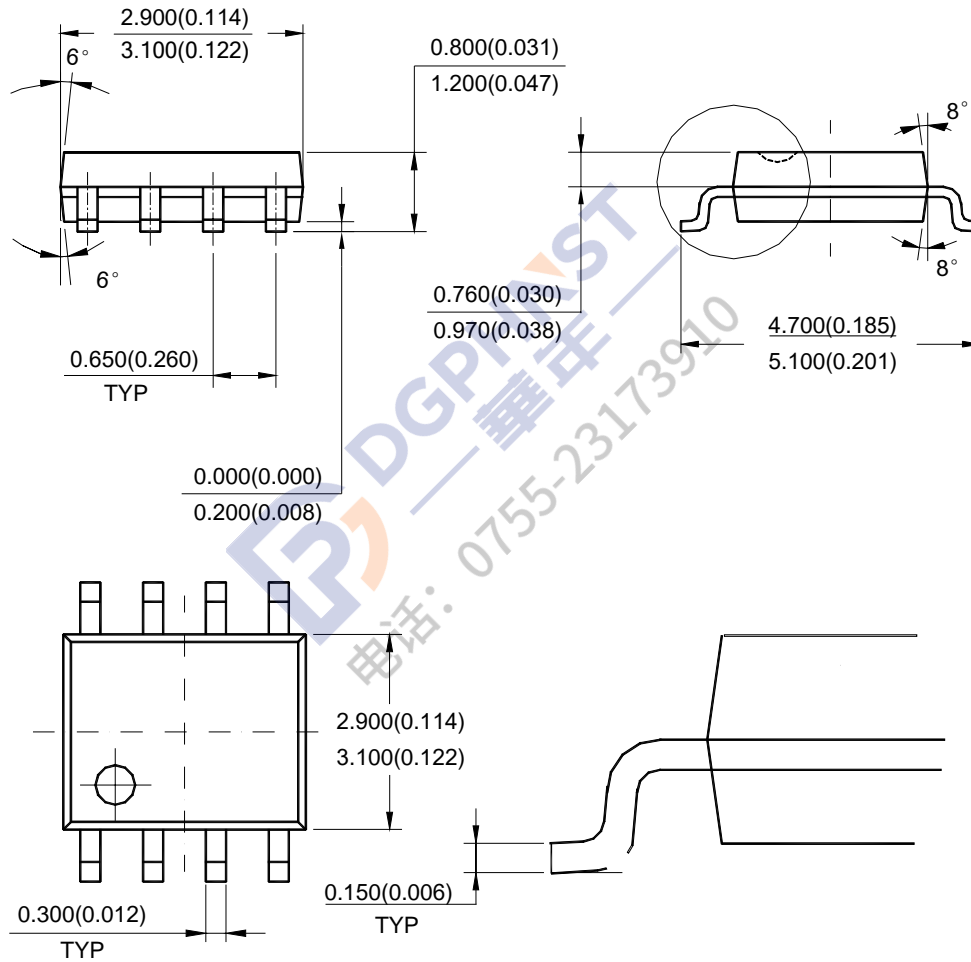

Note: Eject hole, oriented hole and mold mark is optional.

# DISCLAIMER

## IMPORTANT NOTICE, PLEASE READ CAREFULLY

The information in this data sheet is intended to describe the operation and characteristics of our products. JSCJ has the right to make any modification, enhancement, improvement, correction or other changes to any content in this data sheet, including but not limited to specification parameters, circuit design and application information, without prior notice.

Any person who purchases or uses JSCJ products for design shall: 1. Select products suitable for circuit application and design; 2. Design, verify and test the rationality of circuit design; 3. Procedures to ensure that the design complies with relevant laws and regulations and the requirements of such laws and regulations. JSCJ makes no warranty or representation as to the accuracy or completeness of the information contained in this data sheet and assumes no responsibility for the application or use of any of the products described in this data sheet.

Without the written consent of JSCJ, this product shall not be used in occasions requiring high quality or high reliability, including but not limited to the following occasions: medical equipment, automotive electronics, military facilities and aerospace. JSCJ shall not be responsible for casualties or property losses caused by abnormal use or application of this product.

Official Website: [www.jscj-elec.com](http://www.jscj-elec.com)

Copyright © JIANGSU CHANGJING ELECTRONICS TECHNOLOGY CO., LTD.