

Socay High Surge Micro Varistor

SV1210H471G0C

Features

- ◆ RoHS Compliant.
- ◆ SMD Type Body Size 1210.
- ◆ Meet IEC61000-4-5 and UL1449 Standard.
- ◆ Bidirectional and Symmetrical V/I Characteristics.
- ◆ Large Withstanding Surge Current Capability: 300A (@8/20 μ s).
- ◆ Operating Temperature Range: -40 ~ +85 $^{\circ}$ C.
- ◆ Multi-Layers Construction Provides Higher Power Dissipation.
- ◆ Apply in LED lighting market.

Top View (1210)

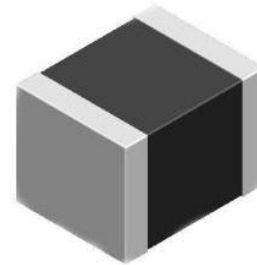

Electrical Characteristics (25 \pm 5 $^{\circ}$ C)

Symbol	Minimum	Typical	Maximum	Units
V_{RMS}	—	—	300	V
V_{DC}	—	—	385	V
V_V	423	—	517	V
V_C	—	—	775	V
C_P	—	190	—	pF
I_{max}	—	—	300	A

Notes:

1. The breakdown voltage was measured at 1mA current.
2. The clamping voltage was measured at 8*20 μ s standard current, 1210(2.5A).
3. The surge current was tested at 8/20 μ s waveform.
4. The capacitance value only for customer reference, it's not formal specification.
5. The components shall be employed within 1 year, in the nitrogen condition.

Socay High Surge Micro Varistor

SV1210H471G0C

Size (Unit: mm)

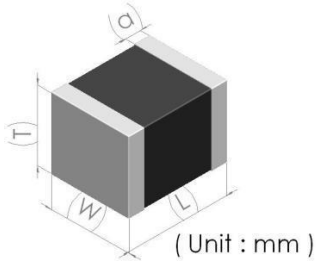

Model	1210
Length(L)	3.20+0.60/-0.20
Width(W)	2.50+0.40/-0.20
Thickness(T)	2.60 Max
Termination(a)	0.50±0.25

Recommended Solder Pad Layout (Unit : mm)

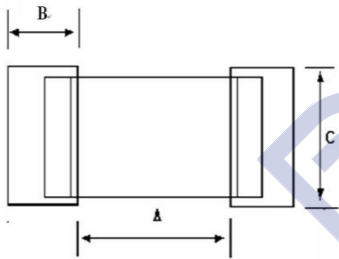

Size	1210
A	1.8~2.5
B	1.3~2.0
C	2.2~3.0

The I_R Reflow and Temperature of Soldering for Pb Free

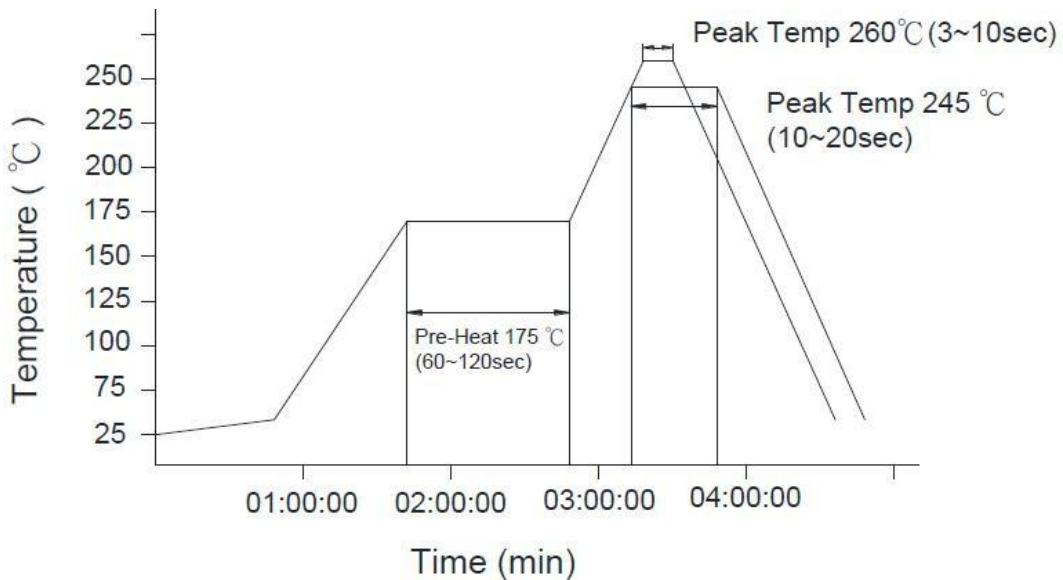

Socay High Surge Micro Varistor

SV1210H471G0C

The IR Reflow and Temperature of Soldering for Pb Free (Continue)

IR reflow Pb free process suggestion profile:

- (1) The solder recommend is Sn96.5/Ag 3.5 of 120 to 150 μ m.
- (2) Ramp-up rate (217 $^{\circ}$ C to peak) +3 $^{\circ}$ C/second max.
- (3) Temp. maintain at 175 \pm 25 $^{\circ}$ C 180 seconds max.
- (4) Temp. maintain above 217 $^{\circ}$ C 60~150 seconds.
- (5) Peak temperature range 245 $^{\circ}$ C+20 $^{\circ}$ C/-10 $^{\circ}$ C time within 5 $^{\circ}$ C of actually peak temperature 10~20 seconds.
- (6) Ramp down rate +6 $^{\circ}$ C/second max.

Perform adequate test in advance as the reflow temperature profile will vary according to the conditions of the manufacturing process, and the specification of the reflow furnace.

Hand Soldering

Resistance to soldering heat-high temperature resistance: 260 $^{\circ}$ C, 10 secs and 3 times.

In hand soldering of the SV1210H471G0C Device. Large temperature gradient between preheated the SV1210H471G0C Device and the tip of soldering iron may cause electrical failures and mechanical damages such as crackings or breaking of the devices. The soldering shall be carefully controlled and carried out so that the temperature gradient is kept minimum with following recommended conditions for hand soldering.

Recommended Soldering Condition 1

- ◆ **Solder:** 0.12~0.18mm Thread solder (Sn96.5:Ag3.5) with soldering flux in the core. Rosin-based and non-activated flux is recommended.
- ◆ **Preheating:** The SV1210H471G0C Device shall be preheated so that Temperature Gradient between the devices and the tip of soldering iron is 150 $^{\circ}$ C or below.
- ◆ **Soldering Iron:** Rated Power of 20w max with 3mm soldering tip in diameter. Temperature of soldering iron tip 380 $^{\circ}$ C max, 3-5sec (The required amount of solder shall be melted in advance on the soldering tip.)
- ◆ **Cooling:** After soldering. The SV1210H471G0C Device shall be cooled gradually at room ambient temperature.

Recommended Soldering Condition 2 (Without preheating)

- ◆ Solder iron tip shall not directly touch to ceramic dielectrics.
- ◆ Solder iron tip shall be fully preheated before soldering while soldering iron tip to the external electrode of SV1210H471G0C Device.

Packaging Specification (Unit: mm)

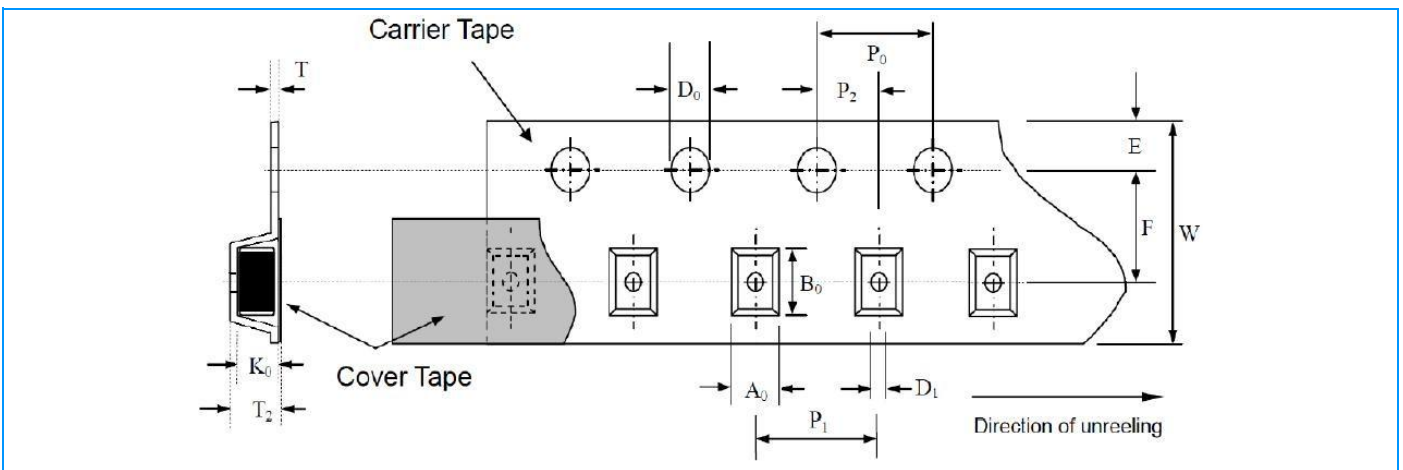

Symbol	A_0 ± 0.10	B_0 ± 0.10	K_0 ± 0.10	T ± 0.05	T_2 ± 0.05	D_0 +0.10 -0.00	D_1 ± 0.05	P_1 ± 0.10	P_2 ± 0.05	P_0 ± 0.05	W ± 0.20	E ± 0.10	F ± 0.05
1210	3.00	3.90	2.70	0.22	2.87	1.50	1.00	4.00	2.00	4.00	8.00	1.75	3.50

Socay High Surge Micro Varistor
SV1210H471G0C
Standard Packaging

Device	Quantity	Reel Size
SV1210H471G0C	1500 pcs	178.0mm

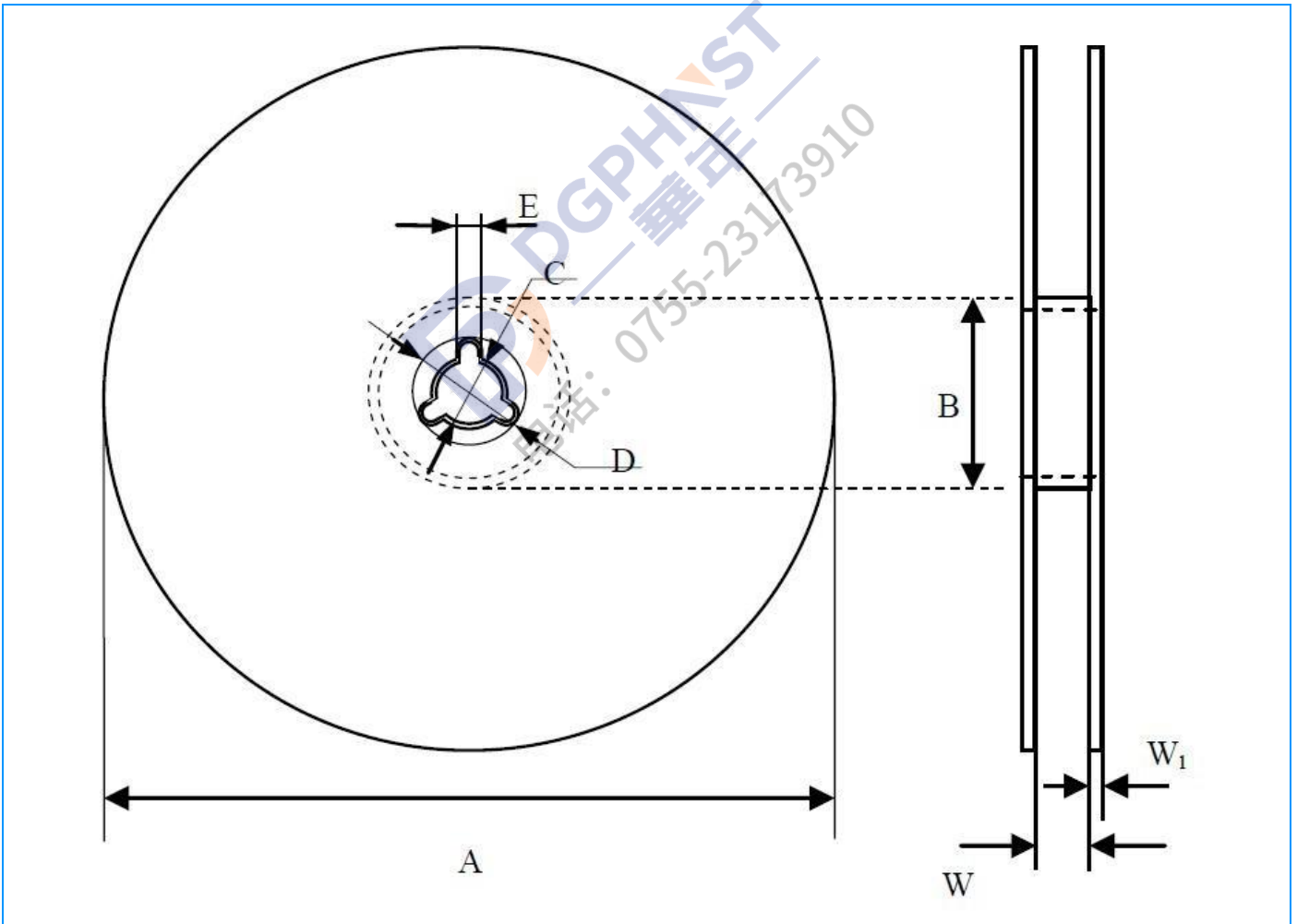
Reel Dimension (Unit: mm)

Symbol	A	B	C	D	E	W	W ₁
1210	178.0±1.0	60.0±0.5	13.0±0.2	21.0±0.2	2.0±0.5	9.0±0.5	1.5±0.15

Socay High Surge Micro Varistor
SV1210H471G0C
Environmental Reliability Testing

Item	Requirement	Test Condition
High Temperature Storage	<ul style="list-style-type: none"> ◆ Breakdown voltage change: within $\pm 10\%$. ◆ No mechanical damage. 	<ul style="list-style-type: none"> ◆ Temperature: $125 \pm 2^\circ\text{C}$. ◆ Time: 1000 ± 2 hours. ◆ Test after placing in ambient temperature for 24 hours.
Low Temperature Storage	<ul style="list-style-type: none"> ◆ Breakdown voltage change: within $\pm 10\%$. ◆ No mechanical damage. 	<ul style="list-style-type: none"> ◆ Temperature: $-40 \pm 2^\circ\text{C}$. ◆ Time: 1000 ± 2 hours. ◆ Test after placing in ambient temperature for 24 hours.
Temperature Cycle	<ul style="list-style-type: none"> ◆ Breakdown voltage change: within $\pm 10\%$. ◆ No mechanical damage. 	<ul style="list-style-type: none"> ◆ Step 1: $-40 \pm 3^\circ\text{C}$; time: $30 \pm 3\text{min}$. ◆ Step 2: 25°C; time: 1 hour. ◆ Step 3: $125 \pm 3^\circ\text{C}$; time: $30 \pm 3\text{min}$. ◆ Step 4: 25°C; time: 1 hour. ◆ Number of cycle: 5 times. ◆ Test after placing in ambient temperature for 24 hours.
High Temperature Load	<ul style="list-style-type: none"> ◆ Breakdown voltage change: within $\pm 10\%$. ◆ No mechanical damage. 	<ul style="list-style-type: none"> ◆ Temperature: $85 \pm 2^\circ\text{C}$. ◆ Rated working voltage applied. ◆ Time: 1000 ± 2 hours. ◆ Test after placing in ambient temperature for 24 hours.
Damp Heat Load/ Humidity Load	<ul style="list-style-type: none"> ◆ Breakdown voltage change: within $\pm 10\%$. ◆ No mechanical damage. 	<ul style="list-style-type: none"> ◆ Temperature: $40 \pm 2^\circ\text{C}$. ◆ Humidity: 90-95% RH. ◆ Rated working voltage applied. ◆ Time: 500 ± 2 hours. ◆ Test after placing in ambient temperature for 24 hours.