

CONTENT

1. Types of Capacitor and Dielectric Material.....	3
2. Product Frame.....	4
3. General Product Parts Numbering System.....	5
4. Product Capacitance Range	6
0402 (1005) Dimensions.....	6
0603 (1608) Dimensions.....	8
0805 (2012) Dimensions.....	10
1206 (3216) Dimensions	12
1210 (3225) Dimensions.....	14
1808 (4520) Dimensions.....	16
1812 (4532) Dimensions.....	17
2220 (5750) Dimensions.....	19
2225 (5764) Dimensions.....	21
5. Dimensions	22
6. Specification and Test Condition	23
7. Packing	34
8. Precautions on the use of MLCC	39

1. Types of Capacitor and Dielectric Material

※COG: The capacitor of this kind dielectric material is considered as Class I capacitor, including general capacitor and high frequency COG capacitor. The electrical properties of COG capacitor are the most stable one and have little change with temperature, voltage and time. They are suited for applications where low-losses and high-stability are required, such as filters, oscillators, and timing circuits.

※ X7R、X5R: material is a kind of material has high dielectric constant. The capacitor made of this kind material is considered as Class II capacitor whose capacitance is higher than that of class I. These capacitors are classified as having a semi-stable temperature characteristic and used over a wide temperature range, such in these kinds of circuits, DC-blocking, decoupling, bypassing, frequency discriminating etc.

※Y5V: The capacitor made of this kind of material is the highest dielectric constant of all ceramic capacitors. They are used over a moderate temperature range in application where high capacitance is required because of its unstable temperature coefficient, but where moderate losses and capacitance changes can be tolerated. Its capacitance and dissipation factors are sensible to measuring conditions, such as temperature and voltage, etc

2. Product Frame

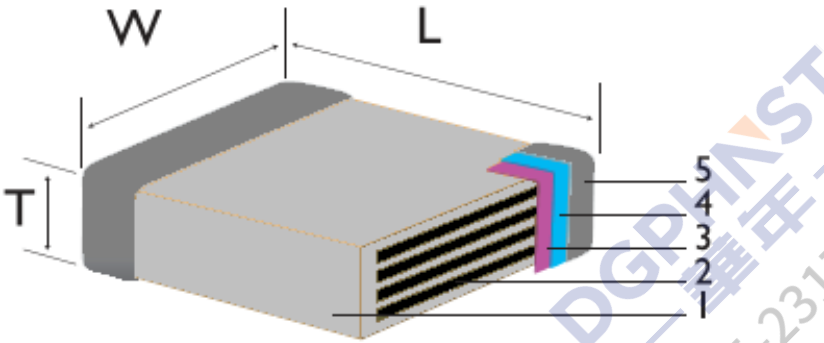

NO.	material
1	ceramic
2	Inner electrode
3	External electrode
4	Ni
5	Sn

DGPHYST
电话: 0755-23173910

3. General Product Parts Numbering System

(example)

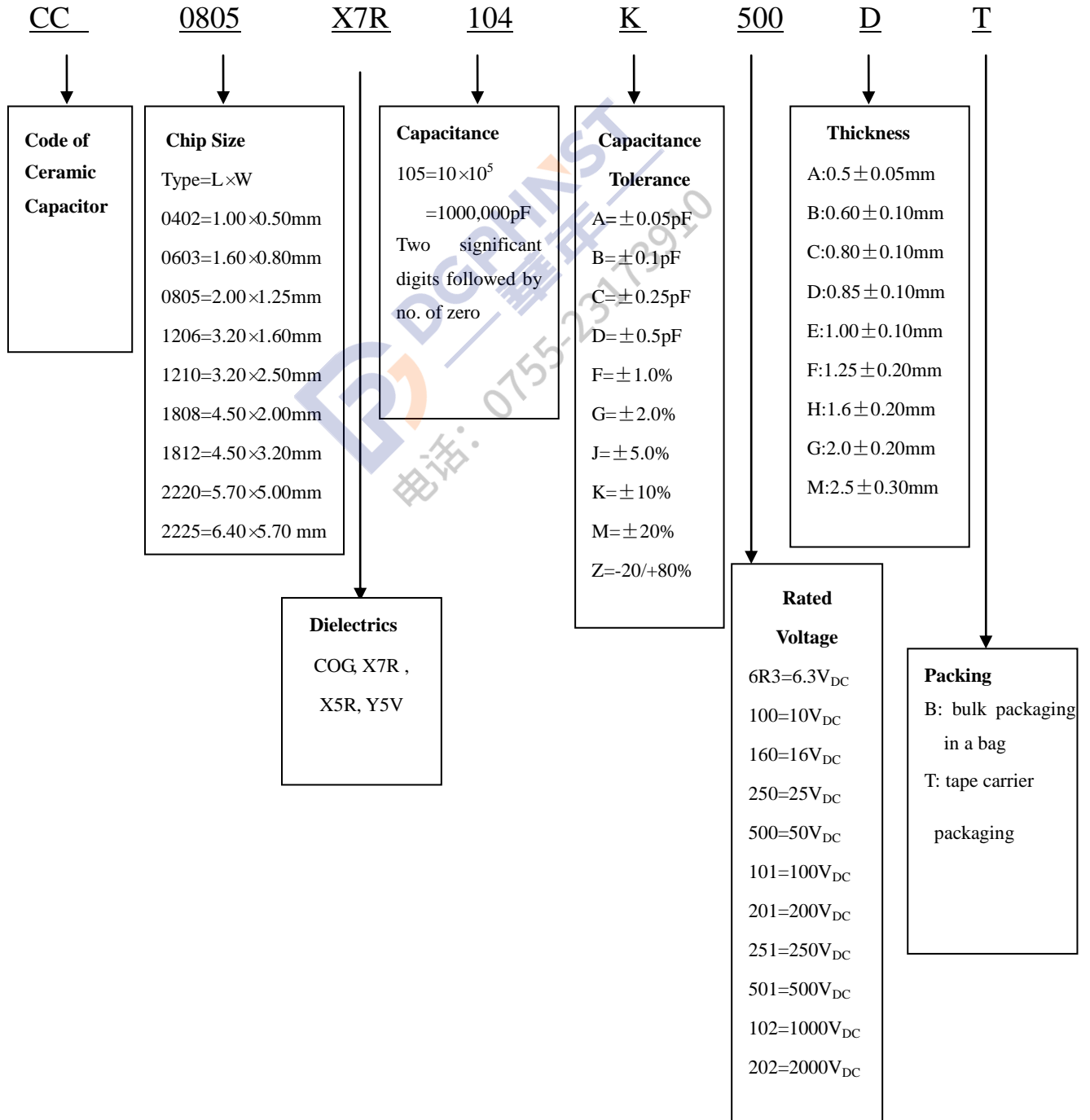

4. Product Capacitance Range

0402	(1005) Dimensions																
	COG系列		X7R系列					X5R系列					Y5V系列				
Cp V _{DC}	50	25	50	25	16	10	6.3	50	25	16	10	6.3	50	25	16	10	6.3
0R5	A	A															
1R0	A	A															
2R0	A	A															
3R0	A	A															
4R0	A	A															
5R0	A	A															
6R0	A	A															
7R0	A	A															
8R0	A	A															
9R0	A	A															
100	A	A															
120	A	A															
150	A	A															
180	A	A															
200	A	A															
220	A	A															
270	A	A															
300	A	A															
330	A	A															
390	A	A															
470	A	A															
560	A	A															
680	A	A															
820	A	A															
101	A	A	A	A	A	A	A	A	A	A	A	A					
121	A	A	A	A	A	A	A	A	A	A	A	A					
151	A	A	A	A	A	A	A	A	A	A	A	A					
181	A	A	A	A	A	A	A	A	A	A	A	A					
201	A	A	A	A	A	A	A	A	A	A	A	A					
221	A	A	A	A	A	A	A	A	A	A	A	A					
271	A	A	A	A	A	A	A	A	A	A	A	A					
331	A	A	A	A	A	A	A	A	A	A	A	A					
391	A	A	A	A	A	A	A	A	A	A	A	A					
471	A	A	A	A	A	A	A	A	A	A	A	A					
561	A	A	A	A	A	A	A	A	A	A	A	A					
681	A	A	A	A	A	A	A	A	A	A	A	A					
821	A	A	A	A	A	A	A	A	A	A	A	A					
102	A	A	A	A	A	A	A	A	A	A	A	A	A	A	A	A	A

		0402(1005)																
		COG系列		X7R系列					X5R系列					Y5V系列				
Cp	V _{DC}	50	25	50	25	16	10	6.3	50	25	16	10	6.3	50	25	16	10	6.3
152				A	A	A	A	A	A	A	A	A	A	A	A	A	A	A
182				A	A	A	A	A	A	A	A	A	A	A	A	A	A	A
222				A	A	A	A	A	A	A	A	A	A	A	A	A	A	A
272				A	A	A	A	A	A	A	A	A	A	A	A	A	A	A
332				A	A	A	A	A	A	A	A	A	A	A	A	A	A	A
472				A	A	A	A	A	A	A	A	A	A	A	A	A	A	A
562				A	A	A	A	A	A	A	A	A	A	A	A	A	A	A
103				A	A	A	A	A	A	A	A	A	A	A	A	A	A	A
153				A	A	A	A	A	A	A	A	A	A	A	A	A	A	A
183					A	A	A	A	A	A	A	A	A	A	A	A	A	A
223					A	A	A	A	A	A	A	A	A	A	A	A	A	A
273					A	A	A	A	A	A	A	A	A	A	A	A	A	A
333					A	A	A	A	A	A	A	A	A	A	A	A	A	A
393					A	A	A	A	A	A	A	A	A	A	A	A	A	A
473					A	A	A	A	A	A	A	A	A	A	A	A	A	A
563					A	A	A	A	A	A	A	A	A	A	A	A	A	A
683					A	A	A	A	A	A	A	A	A	A	A	A	A	A
104						A	A	A			A	A	A		A	A	A	A
154						A	A	A			A	A	A			A	A	A
184							A	A				A	A			A	A	A
224							A	A				A	A			A	A	A
274								A					A				A	A
334								A					A				A	A
474								A					A				A	A
684								A					A					A
105								A					A					A

Tolerance: COG(0.5pF~4.9pF): C COG(5.0pF~9.9pF): D; COG(≥ 10 pF): F($\pm 1\%$), G($\pm 2\%$), J($\pm 5\%$)

X7R/X5R: J($\pm 5.0\%$); K($\pm 10\%$); M($\pm 20\%$)

Y5V: M($\pm 20\%$); Z(-20,+80%)

Thickness: A: 0.50 ± 0.10 mm ;

Above capacitance for reference only, actual cap. Range depends on the standard products.

0603(1608)Dimensions

Cp V _{DC}	COG系列					X7R系列								X5R系列					Y5V系列				
	250	200	100	50	25	250	200	100	50	25	16	10	6.3	50	25	16	10	6.3	50	25	16	10	
0R5	c	c	c	c	c																		
1R0	c	c	c	c	c																		
2R0	c	c	c	c	c																		
3R0	c	c	c	c	c																		
4R0	c	c	c	c	c																		
5R0	c	c	c	c	c																		
6R0	c	c	c	c	c																		
7R0	c	c	c	c	c																		
8R0	c	c	c	c	c																		
9R0	c	c	c	c	c																		
100	c	c	c	c	c																		
120	c	c	c	c	c																		
150	c	c	c	c	c																		
180	c	c	c	c	c																		
200	c	c	c	c	c																		
220	c	c	c	c	c																		
270	c	c	c	c	c																		
300	c	c	c	c	c																		
330	c	c	c	c	c																		
390	c	c	c	c	c																		
470	c	c	c	c	c																		
560	c	c	c	c	c																		
680	c	c	c	c	c																		
820	c	c	c	c	c																		
101	c	c	c	c	c	c	c	c															
121	c	c	c	c	c	c	c	c															
151	c	c	c	c	c	c	c	c															
181	c	c	c	c	c	c	c	c															
201	c	c	c	c	c	c	c	c															
221	c	c	c	c	c	c	c	c	c	c	c	c	c	c	c	c	c	c					
271	c	c	c	c	c	c	c	c	c	c	c	c	c	c	c	c	c	c					
331	c	c	c	c	c	c	c	c	c	c	c	c	c	c	c	c	c	c					
391	c	c	c	c	c	c	c	c	c	c	c	c	c	c	c	c	c	c					
471	c	c	c	c	c	c	c	c	c	c	c	c	c	c	c	c	c	c					
561			c	c	c	c	c	c	c	c	c	c	c	c	c	c	c	c					
681			c	c	c	c	c	c	c	c	c	c	c	c	c	c	c	c					
821			c	c	c	c	c	c	c	c	c	c	c	c	c	c	c	c					
102				c	c	c	c	c	c	c	c	c	c	c	c	c	c	c	c	c	c	c	c

MULTILAYER CERAMIC CHIP CAPACITORS



		0603(1608)																				
		COG系列				X7R系列							X5R系列					Y5V系列				
Cp	V _{DC}	250	100	50	25	250	100	50	25	16	10	6.3	50	25	16	10	6.3	50	25	16	10	
152				c	c	c	c	c	c	c	c	c	c	c	c	c	c	c	c	c	c	c
182					c	c	c	c	c	c	c	c	c	c	c	c	c	c	c	c	c	c
222					c	c	c	c	c	c	c	c	c	c	c	c	c	c	c	c	c	c
272						c	c	c	c	c	c	c	c	c	c	c	c	c	c	c	c	c
332						c	c	c	c	c	c	c	c	c	c	c	c	c	c	c	c	c
472						c	c	c	c	c	c	c	c	c	c	c	c	c	c	c	c	c
562						c	c	c	c	c	c	c	c	c	c	c	c	c	c	c	c	c
682						c	c	c	c	c	c	c	c	c	c	c	c	c	c	c	c	c
103							c	c	c	c	c	c	c	c	c	c	c	c	c	c	c	c
153							c	c	c	c	c	c	c	c	c	c	c	c	c	c	c	c
183							c	c	c	c	c	c	c	c	c	c	c	c	c	c	c	c
223								c	c	c	c	c	c	c	c	c	c	c	c	c	c	c
273									c	c	c	c	c	c	c	c	c	c	c	c	c	c
333									c	c	c	c	c	c	c	c	c	c	c	c	c	c
393									c	c	c	c	c	c	c	c	c	c	c	c	c	c
473									c	c	c	c	c	c	c	c	c	c	c	c	c	c
563									c	c	c	c	c	c	c	c	c	c	c	c	c	c
683									c	c	c	c	c	c	c	c	c	c	c	c	c	c
104									c	c	c	c	c	c	c	c	c	c	c	c	c	c
154									c	c	c	c	c	c	c	c	c	c	c	c	c	c
184									c	c	c	c	c	c	c	c	c	c	c	c	c	c
224									c	c	c	c	c	c	c	c	c	c	c	c	c	c
274									c	c	c	c	c	c	c	c	c	c	c	c	c	c
334									c	c	c	c	c	c	c	c	c	c	c	c	c	c
474									c	c	c	c	c	c	c	c	c	c	c	c	c	c
684										c	c	c	c		c	c	c	c		c	c	c
105										c	c	c	c		c	c	c	c		c	c	c
225											c	c	c			c	c	c			c	c
475												c	c				c	c				c
106												c					c					c

Tolerance: COG(0.5pF~4.9pF): C COG(5.0pF~9.9pF): D; COG(≥ 10 pF): F($\pm 1\%$), G($\pm 2\%$), J($\pm 5\%$)

X7R/X5R: J($\pm 5.0\%$); K($\pm 10\%$); M($\pm 20\%$); Y5V: M($\pm 20\%$); Z(-20,+80%)

Thickness: C: 0.80 ± 0.1 mm ; Above capacitance for reference only, actual cap. Range depends on the standard products.

0805(2012)Dimensions

		0805(2012)																							
		COG系列					X7R系列								X5R系列					Y5V系列					
Cp	V _{DC}	500	250	100	50	25	16	500	250	100	50	25	16	10	6.3	50	25	16	10	6.3	50	25	16	10	6.3
0R5		B	B	B	B	B	B																		
1R0		B	B	B	B	B	B																		
2R0		B	B	B	B	B	B																		
3R0		B	B	B	B	B	B																		
4R0		B	B	B	B	B	B																		
5R0		B	B	B	B	B	B																		
6R0		B	B	B	B	B	B																		
7R0		B	B	B	B	B	B																		
8R0		B	B	B	B	B	B																		
9R0		B	B	B	B	B	B																		
100		B	B	B	B	B	B																		
120		B	B	B	B	B	B																		
150		B	B	B	B	B	B																		
180		B	B	B	B	B	B																		
200		B	B	B	B	B	B																		
220		B	B	B	B	B	B																		
270		B	B	B	B	B	B																		
300		B	B	B	B	B	B																		
330		B	B	B	B	B	B																		
390		B	B	B	B	B	B																		
470		B	B	B	B	B	B																		
560		B	B	B	B	B	B																		
680		B	B	B	B	B	B																		
820		B	B	B	B	B	B																		
101		B/D/F	B	B	B	B	B	F	F	F															
121		B/D/F	B	B	B	B	B	F	F	F															
151		B/D/F	B	B	B	B	B	F	F	F															
181		B/D/F	B	B	B	B	B	F	F	F															
201		B/D/F	B	B	B	B	B	F	F	F															
221		B/D/F	B	B	B	B	B	F	F	F	B	B	B	B	B	B	B	B	B	B	B	B	B	B	B
271		B/D/F	B	B	B	B	B	F	F	F	B	B	B	B	B	B	B	B	B	B	B	B	B	B	B
331		B/D/F	B	B	B	B	B	D/F	D/F	D/F	B/D	B/D	B/D	B/D	B/D	B/D	B/D	B/D	B/D	B/D	B/D	B/D	B/D	B/D	B/D
391		B/D/F	B	B	B	B	B	D/F	D/F	D/F	B/D	B/D	B/D	B/D	B/D	B/D	B/D	B/D	B/D	B/D	B/D	B/D	B/D	B/D	B/D
471		B/D/F	B	B	B	B	B	D/F	D/F	D/F	B/D	B/D	B/D	B/D	B/D	B/D	B/D	B/D	B/D	B/D	B/D	B/D	B/D	B/D	B/D
561		D/F	B	B	B	B	B	D/F	D/F	D/F	B/D	B/D	B/D	B/D	B/D	B/D	B/D	B/D	B/D	B/D	B/D	B/D	B/D	B/D	B/D
681			B	B	B	B	B	D/F	D/F	D/F	B/D	B/D	B/D	B/D	B/D	B/D	B/D	B/D	B/D	B/D	B/D	B/D	B/D	B/D	B/D
821			B	B	B	B	B	D/F	D/F	D/F	B/D	B/D	B/D	B/D	B/D	B/D	B/D	B/D	B/D	B/D	B/D	B/D	B/D	B/D	B/D
102			B	B	B	B	B	D/F	D/F	D/F	B/D	B/D	B/D	B/D	B/D	B/D	B/D	B/D	B/D	B/D	B/D	B/D	B/D	B/D	D

		0805(2012)																							
		COG系列					X7R系列								X5R系列					Y5V系列					
Cp	V _{DC}	500	250	100	50	25	16	500	250	100	50	25	16	10	6.3	50	25	16	10	6.3	50	25	16	10	6.3
152			B	B	B	B	B	D/F	D/F	D/F	B/D	B/D	B/D	B/D	B/D	B/D	B/D	B/D	B/D	B/D	D	D	D	D	D
182				B	B	B	B	D/F	D/F	D/F	B/D	B/D	B/D	B/D	B/D	B/D	B/D	B/D	B/D	B/D	D	D	D	D	D
222				B	B	B	B	D/F	D/F	D/F	B/D	B/D	B/D	B/D	B/D	B/D	B/D	B/D	B/D	B/D	D	D	D	D	D
272					B	B	B	D/F	D/F	D/F	B/D	B/D	B/D	B/D	B/D	B/D	B/D	B/D	B/D	B/D	D	D	D	D	D
332						D	D	F	D/F	D/F	D	D	D	D	D	D	D	D	D	D	D	D	D	D	D
472						D	D	F	D/F	D/F	D	D	D	D	D	D	D	D	D	D	D	D	D	D	D
562						D	D	F	D/F	D/F	D	D	D	D	D	D	D	D	D	D	D	D	D	D	D
682						D	F	D/F	D/F	D	D	D	D	D	D	D	D	D	D	D	D	D	D	D	D
103							F	D/F	D/F	D	D	D	D	D	D	D	D	D	D	D	D	D	D	D	D
153							F	D/F	D	D	D	D	D	D	D	D	D	D	D	D	D	D	D	D	D
183							F	D/F	D	D	D	D	D	D	D	D	D	D	D	D	D	D	D	D	D
223							F	D/F	D	D	D	D	D	D	D	D	D	D	D	D	D	D	D	D	D
273							F	D/F	D	D	D	D	D	D	D	D	D	D	D	D	D	D	D	D	D
333							F	D/F	D	D	D	D	D	D	D	D	D	D	D	D	D	D	D	D	D
393							F	D/F	D	D	D	D	D	D	D	D	D	D	D	D	D	D	D	D	D
473							F	D/F	D	D	D	D	D	D	D	D	D	D	D	D	D	D	D	D	D
563								D/F	D	D	D	D	D	D	D	D	D	D	D	D	D	D	D	D	D
683								D/F	D	D	D	D	D	D	D	D	D	D	D	D	D	D	D	D	D
104								D/F	D	D	D	D	D	D	D	D	D	D	D	D	D	D	D	D	D
154									D	D	D	D	D	D	D	D	D	D	D	D	D	D	D	D	D
184									D	D	D	D	D	D	D	D	D	D	D	D	D	D	D	D	D
224									D/F	D	D	D	D	D	D/F	D	D	D	D	D	D/F	D	D	D	D
274									D/F	D	D	D	D	D	D/F	D	D	D	D	D	D/F	D	D	D	D
334									D/F	D	D	D	D	D	D/F	D	D	D	D	D	D/F	D	D	D	D
474									D/F	D/F	D/F	D	D	D	D/F	D/F	D/F	D	D	D	D/F	D/F	D/F	D	D
684									D	D/F	D/F	D	D	D	D	D/F	D/F	D	D	D	D	D/F	D/F	D	D
105									D	D/F	D/F	D	D	D	D	D/F	D/F	D	D	D	D	D/F	D/F	D	D
225										F	F	F	F		F	F	F	F			F	F	F	F	
475										F	F	F	F		F	F	F	F				F	F	F	
106										F	F	F			F	F	F						F	F	
226											F	F				F	F							F	
476												F								F					

Tolerance: COG(0.5pF~4.9pF): C COG(5.0pF~9.9pF): D; COG(≥10pF): F(±1%), G(±2%), J(±5%)

X7R/X5R: J(±5.0%); K(±10%); M(±20%); Y5V: M(±20%); Z(-20,+80%)

Thickness: B: 0.60±0.1mm、D: 0.85±0.1mm、F: 1.25±0.2mm; Above capacitance for reference only, actual cap.

Range depends on the standard products.

1206(3216)Dimensions

Cp V _{DC}	1206(3216)																													
	COG系列									X7R系列										X5R系列					Y5V系列					
	2000	1000	630	500	250	100	50	25	16	2000	1000	630	500	250	100	50	25	16	10	6.3	50	25	16	10	6.3	50	25	16	10	6.3
0R5	D	D	D	D	D	D	D	D	D																					
1R0	D	D	D	D	D	D	D	D	D																					
2R0	D	D	D	D	D	D	D	D	D																					
3R0	D	D	D	D	D	D	D	D	D																					
4R0	D	D	D	D	D	D	D	D	D																					
5R0	D	D	D	D	D	D	D	D	D																					
6R0	D	D	D	D	D	D	D	D	D																					
7R0	D	D	D	D	D	D	D	D	D																					
8R0	D	D	D	D	D	D	D	D	D																					
9R0	D	D	D	D	D	D	D	D	D																					
100	D	D	D	D	D	D	D	D	D																					
120	D	D	D	D	D	D	D	D	D																					
150	D	D	D	D	D	D	D	D	D																					
180	D	D	D	D	D	D	D	D	D																					
200	D	D	D	D	D	D	D	D	D																					
220	D/E/ F	D	D	D	D	D	D	D	D																					
270	D/E/ F	D	D	D	D	D	D	D	D																					
300	D/E/ F	D	D	D	D	D	D	D	D																					
330	D/E/ F	D	D	D	D	D	D	D	D																					
390	D/E/ F	D	D	D	D	D	D	D	D																					
470	D/E/ F	D	D	D	D	D	D	D	D																					
560	D/E/ F	D	D	D	D	D	D	D	D																					
680	D/E/ F	D	D	D	D	D	D	D	D																					
820	D/E/ F	D	D	D	D	D	D	D	D																					
101	D/E/ F	D/E	D	D	D	D	D	D	D	F	F	F	F	F																
121	D/E/ F	D/E	D	D	D	D	D	D	D	F	F	F	F	F																
151		D/E	D	D	D	D	D	D	D	F	F	F	F	F																
181		D/E	D	D	D	D	D	D	D	F	F	F	F	F																
201		D/E	D	D	D	D	D	D	D	F	F	F	F	F																
221		D/E	D	D	D	D	D	D	D	F	F	F	F	F	D	D	D	D	D	D	D	D	D	D	D	D	D	D		
271		D/E	D	D	D	D	D	D	D	F	F	F	F	F	D	D	D	D	D	D	D	D	D	D	D	D	D	D		
331		D/E	D	D	D	D	D	D	D	F	F	F	F	F	D	D	D	D	D	D	D	D	D	D	D	D	D	D		
391		D/E	D	D	D	D	D	D	D	F	F	F	F	F	D	D	D	D	D	D	D	D	D	D	D	D	D	D		
471		D/E	D	D	D	D	D	D	D	F	F	F	F	F	D	D	D	D	D	D	D	D	D	D	D	D	D	D		
561			D	D	D	D	D	D	D	F	F	F	F	F	D	D	D	D	D	D	D	D	D	D	D	D	D	D		
681			D	D	D	D	D	D	D	F	F	F	F	F	D	D	D	D	D	D	D	D	D	D	D	D	D	D		
821			D	D	D	D	D	D	D	F	F	F	F	F	D	D	D	D	D	D	D	D	D	D	D	D	D	D		
102			D	D	D	D	D	D	D	F	F	F	F	F	D	D	D	D	D	D	D	D	D	D	D	D	D	D		

MULTILAYER CERAMIC CHIP CAPACITORS



		1206(3216)																													
		COG系列								X7R系列										X5R系列					Y5V系列						
C _p	V _{dc}	2000	1000	630	500	250	100	50	25	16	2000	1000	630	500	250	100	50	25	16	10	6.3	50	25	16	10	6.3	50	25	16	10	6.3
152				D	D	D	D	D	D	D			F	F	F	F	D	D	D	D	D	D	D	D	D	D	D	D	D	D	D
182							D	D	D	D			F	F	F	F	D	D	D	D	D	D	D	D	D	D	D	D	D	D	D
222							D	D	D	D			F	F	F	F	D	D	D	D	D	D	D	D	D	D	D	D	D	D	D
272							D	D	D	D			F	F	F	F	D	D	D	D	D	D	D	D	D	D	D	D	D	D	D
332							D	D	D	D			F	F	F	F	D	D	D	D	D	D	D	D	D	D	D	D	D	D	D
472							D	D	D	D			F	F	F	F	D	D	D	D	D	D	D	D	D	D	D	D	D	D	D
562							D	D	D	D			F	F	F	F	D	D	D	D	D	D	D	D	D	D	D	D	D	D	D
682									D	D			F	F	F	F	D	D	D	D	D	D	D	D	D	D	D	D	D	D	D
103									F	F			F	F	F	F	D	D	D	D	D	D	D	D	D	D	D	D	D	D	D
153													F	F	F	D	D	D	D	D	D	D	D	D	D	D	D	D	D	D	D
183													F	F	F	D	D	D	D	D	D	D	D	D	D	D	D	D	D	D	D
223													F	F	F	D	D	D	D	D	D	D	D	D	D	D	D	D	D	D	D
273													F	F	D	D	D	D	D	D	D	D	D	D	D	D	D	D	D	D	D
333													F	F	D	D	D	D	D	D	D	D	D	D	D	D	D	D	D	D	D
393													F	F	D	D	D	D	D	D	D	D	D	D	D	D	D	D	D	D	D
473													F	F	D	D	D	D	D	D	D	D	D	D	D	D	D	D	D	D	D
563													F	F	D	D	D	D	D	D	D	D	D	D	D	D	D	D	D	D	D
683													F	F	D	D	D	D	D	D	D	D	D	D	D	D	D	D	D	D	D
104													F	F	D	D	D	D	D	D	D	D	D	D	D	D	D	D	D	D	D
154															D	D	D	D	D	D	D	D	D	D	D	D	D	D	D	D	D
184															D	D	D	D	D	D	D	D	D	D	D	D	D	D	D	D	D
224															D	D	D	D	D	D	D	D	D	D	D	D	D	D	D	D	D
274															D	D	D	D	D	D	D	D	D	D	D	D	D	D	D	D	D
334															D	D	D	D	D	D	D	D	D	D	D	D	D	D	D	D	D
474													F	F	F	F	F	F	F	F	F	F	F	F	F	F	F	F	F	F	F
684													F/H	F/H	F	F	F	F	F	F	F	F	F/H	F	F	F	F	F	F	F	F
105													F/H	F/H	F	F	F	F	F	F	F	F/H	F	F	F	F	F	F	F	F	F
205																															
225																															
475																															
106																															
226																															
476																															

Tolerance: COG(0.5pF~4.9pF): C ;COG(5.0pF~9.9pF): D; COG(≥10pF): F(±1%), G(±2%), J(±5%)

X7R/X5R: J(±5.0%); K(±10%); M(±20%); Y5V: M(±20%); Z(-20,+80%)

Thickness: D: 0.85±0.1mm、E: 1.00±0.1mm、F: 1.25±0.2mm、H: 1.60±0.2mm、1.60±0.3*mm; Above capacitance for reference only, actual cap. Range depends on the standard products.

1210(3225)Dimensions

		1210(3225)																											
		COG系列					X7R系列										X5R系列					Y5V系列							
Cp	V _{DC}	2000	1000	500	250	100	50	2000	1000	630	500	250	100	50	25	16	10	6.3	50	25	16	10	6.3	50	25	16	10	6.3	
100	D																												
120	D																												
150	D																												
180	D																												
200	D																												
220	D																												
270	D																												
300	D																												
330	D																												
390	D																												
470	D																												
560	D																												
680	D																												
820	D																												
101	D	D	D	D	D	D	D																						
121	F	D	D	D	D	D	D																						
151	F	D	D	D	D	D	D																						
181	F	D	D	D	D	D	D																						
201	F	D	D	D	D	D	D																						
221	F	D	D	D	D	D	D	F	F	F	F	F	F																
271		D	D	D	D	D	D	F	F	F	F	F	F																
331		D	D	D	D	D	D	F	F	F	F	F	F																
391		D	D	D	D	D	D	F	F	F	F	F	F																
471		D	D	D	D	D	D	F	F	F	F	F	F																
561		F	D	D	D	D	D	F	F	F	F	F	F																
681		F	D	D	D	D	D	F	F	F	F	F	F																
821		F	D	D	D	D	D	F	F	F	F	F	F																
102		F	D	D	D	D	D	F	F	F	F	F	F																
152			D	D	D	D	D	F	F	F	F	F	F																
182			D	D	D	D	D	F	F	F	F	F	F																
222			D	D	D	D	D	F	F	F	F	F	F																
272			F	D	D	D	D		F	F	F	F	F																
332				D	D	D	D		F	F	F	F	F																
472				D	D	D	D		F	F	F	F	F																
562									F	F	F	F	F																
682									F	F	F	F	F																
103									F	F	F	F	F																
153									F	F	F	F	F																
223										H	H	F	F																
333										H	H	F	F																
473										G	G	F	F																
563												F	F																
683												F	F																
104												F	F																
154												H	H																
224												G	H																
334													G																
394													G																
474												G	G	G	G	G	G	G	G	G	G	G	G	G	G	G	G	G	G
684												H	H	H	H	H	H	H	H	H	H	H	H	H	H	H	H	H	H
105												H	H	H	H	H	H	H	H	H	H	H	H	H	H	H	H	H	H
225												H	H	H	H	H	H	H	H	H	H	H	H	H	H	H	H	H	H
475												H/G	H	H	H				H/G	H	H	H			H/G	H	H	H	
106													M	G	M	M			M	G	M	M			M	G	M	M	
226														M	M	M				M	M	M				M	M	M	
476															M	M					M	M					M	M	
107																	M						M						M

Tolerance: COG($\geq 10\text{pF}$): F($\pm 1\%$), G($\pm 2\%$), J($\pm 5\%$); X7R/X5R: J($\pm 5.0\%$); K($\pm 10\%$); M($\pm 20\%$);
Y5V: M($\pm 20\%$); Z(-20,+80%)

Thickness: D: $0.85 \pm 0.1\text{mm}$ 、F: $1.25 \pm 0.2\text{mm}$ 、H: $1.60 \pm 0.2\text{mm}$ 、G: $2.00 \pm 0.20\text{mm}$ M: $2.50 \pm 0.30\text{mm}$;

Above capacitance for reference only, actual cap. Range depends on the standard products.



1808(4520)Dimensions

		1808(4520)												
		COG系列					X7R系列					Y5V系列		
Cp	V _{DC}	2000	1000	500	250	50	2000	1000	500	250	100	50	25	16
101		F	F	F	F	F								
121		F	F	F	F	F								
151		F	F	F	F	F								
181		F	F	F	F	F								
201		F	F	F	F	F								
221		F	F	F	F	F	F	F	F	F	F			
271		F	F	F	F	F	F	F	F	F	F			
331		F	F	F	F	F	F	F	F	F	F			
391		F	F	F	F	F	F	F	F	F	F			
471		F	F	F	F	F	F	F	F	F	F			
561		F	F	F	F	F	F	F	F	F	F			
681		F	F	F	F	F	F	F	F	F	F			
821		F	F	F	F	F	F	F	F	F	F			
102		F	F	F	F	F	F	F	F	F	F			
222			F	F	F	F		F	F	F	F			
332			F	F	F	F		F	F	F	F			
472				F	F			F	F	F	F			
562					F			F	F	F	F			
103								F	F	F	F			
153								F	F	F	F			
223									F	F	F			
333									F	F	F			
473									F	F	F			
563										F	F			
683										F	F			
104										F	F			
224										F	F			
474											F			
105											F			
225												F	F	F
475													H	H
106														H

Tolerance: COG($\geq 10\text{pF}$): F($\pm 1\%$), G($\pm 2\%$), J($\pm 5\%$); X7R: J($\pm 5.0\%$); K($\pm 10\%$); M($\pm 20\%$);
 Y5V: M($\pm 20\%$); Z(-20,+80%)

Thickness: F: $1.25 \pm 0.2\text{mm}$, H: $1.60 \pm 0.2\text{mm}$; Above capacitance for reference only, actual cap. Range depends on the standard products.

1812 (4532) Dimensions

		1812(4532)																				
		COG系列						X7R系列								X5R系列			Y5V系列			
Cp	V _{DC}	3000	2000	1000	500	250	100	50	2000	1000	500	250	100	50	25	16	50	25	16	50	25	16
470	E																					
560	E																					
680	E																					
820	E																					
101	E	F	F	F	F			D														
121	H	F	F	F	F			D														
151	H	F	F	F	F			D														
181	H	F	F	F	F			D														
201	H	F	F	F	F			D														
221	H	F	F	F	F			D	F	F	F	F	F									
271		F	F	F	F			D	F	F	F	F	F									
331		F	F	F	F			D	F	F	F	F	F									
391		F	F	F	F			D	F	F	F	F	F									
471		F	F	F	F			D	F	F	F	F	F									
561		F	F	F	F			D	F	F	F	F	F									
681		F	F	F	F			D	F	F	F	F	F									
821		F	F	F	F			D	F/H	F	F	F	F									
102		F	F	F	F			D	F/H	F	F	F	F									
222				F	F				F/H	F	F	F	F									
332				F	F				F/H	F	F	F	F									
472				F	F				F/H	F	F	F	F									
562					F					F/H	F	F	F									
682						F				F/H	F	F	F									
103						F				F/H	F	F	F									
153										F/H	F	F	F									
223										F/H	F	F	F									
333											F	F	F									
473											F/H	F	F									
563											F	F	F									
683											F	F	F									
104											G	F/H	F									
224												F/H	F									
334												G	F									
474												G	F	F	F	F	F	F	F			
684													G/H	G/H	G/H	G/H	G/H	G/H	G/H			
105													G	G	G	G	G	G	G			
225													G	F/H	F/H	F/H	F/H	F/H	F/H	F/H	F/H	F/H
475													G	G	G	G	G	G	G	G	G	G
106														G	M		G	M			G	M
226															M			M				M
476																						M
107																						

Tolerance: COG($\geq 10\text{pF}$): F($\pm 1\%$), G($\pm 2\%$), J($\pm 5\%$); X7R/X5R: J($\pm 5.0\%$); K($\pm 10\%$); M($\pm 20\%$);
Y5V: M($\pm 20\%$); Z(-20,+80%)

Thickness: D: $0.85 \pm 0.1\text{mm}$ 、E: $1.00 \pm 0.1\text{mm}$ 、F: $1.25 \pm 0.2\text{mm}$ 、H: $1.60 \pm 0.2\text{mm}$ 、G: $2.00 \pm 0.20\text{mm}$ 、
M: $2.50 \pm 0.30\text{mm}$;

Above capacitance for reference only, actual cap. Range depends on the standard products.

 DGP HNS
— 華年 —
电话: 0755-23173910

2220(5750)Dimensions

		2220(5750)													
		COG系列	X7R系列						X5R系列		Y5V系列				
Cp	V _{DC}	50	2000	1000	500	250	100	50	25	50	25	50	25	16	
101	E														
121	E														
151	E														
181	E														
201	E														
221	E		H	H	H	H	H								
271	E		H	H	H	H	H								
331	E		H	H	H	H	H								
391	E		H	H	H	H	H								
471	E		H	H	H	H	H								
561	E		H	H	H	H	H								
681	E		H	H	H	H	H								
821	E		H	H	H	H	H								
102	E		F/H	H	H	H	H								
222	E		F/H	H	H	H	H								
332			F/H	H	H	H	H								
472			F/H	H	H	H	H								
562			F/H	H	H	H	H								
103			F/H	H	H	H	H								
223				F/H	H	H	H								
333				F/H	H	H	H								
473				F/H	H	H	H								
563				G	G	G	G								
683				G	G	G	G								
104				G	G	G	G								
224					G	G	G								
334					G	G	G								
474						F/H /G	F/H /G	F/H /G	F/H /G	F/H/ G	F/H/ G				
684						F/H /G	F/H /G	F/H /G	F/H /G	F/H/ G	F/H/ G				
105						G	G	M	M	M	M				
155							H	H	H	H	H				
225								G	M	M	M	M	G	G	G
475								G	G	M	G	M	G	G	G
106									G	M	G	M	G	G	G
226													M	M	M
476														M	M
107															M

MULTILAYER CERAMIC CHIP CAPACITORS



Tolerance: COG($\geq 10\text{pF}$): F($\pm 1\%$), G($\pm 2\%$), J($\pm 5\%$); X7R: J($\pm 5.0\%$); K($\pm 10\%$); M($\pm 20\%$);
Y5V: M($\pm 20\%$); Z(-20,+80%)

Thickness: E: $1.00 \pm 0.1\text{mm}$ 、F: $1.25 \pm 0.2\text{mm}$ 、H: $1.60 \pm 0.20\text{mm}$ 、G: $2.00 \pm 0.20\text{mm}$ 、M: $2.50 \pm 0.30\text{mm}$;

Above capacitance for reference only, actual cap. Range depends on the standard products.



2225(5764)Dimensions

		2225(5764)			
		COG系列	X7R系列		Y5V系列
Cp	V _{DC}	50	400	250	50 25
101	E				
121	E				
151	E				
181	E				
201	E				
221	E				
271	E				
331	E				
391	E				
471	E				
561	E				
681	E				
821	E				
102	E	G	G		
222	E	G	G		
332	E	G	G		
472	E	G	G		
562	E	G	G		
103	E	G	G		
223	E	G	G		
333	E	G	G		
473	E	G	G		
563	E	G	G		
683		G	G		
104		G	G		
224		G	G		
334		G	G		
474		G	G		
684		G	G		
225				M	M
475				M	M
106					M

容量容差: COG($\geq 10\text{pF}$): F($\pm 1\%$), G($\pm 2\%$), J($\pm 5\%$), K($\pm 10\%$); X7R: J($\pm 5.0\%$); K($\pm 10\%$); M($\pm 20\%$);

Tolerance: COG($\geq 10\text{pF}$): F($\pm 1\%$), G($\pm 2\%$), J($\pm 5\%$); X7R: J($\pm 5.0\%$); K($\pm 10\%$); M($\pm 20\%$);

Y5V: M($\pm 20\%$); Z(-20,+80%)

Thickness: E: $1.10 \pm 0.1\text{mm}$ 、G: $2.00 \pm 0.20\text{mm}$ 、M: $2.50 \pm 0.30\text{mm}$;

Above capacitance for reference only, actual cap. Range depends on the standard products.

5. Dimensions

Chip Size: 0402,0603,0805,1206,1210,1808,1812 ,2220 and 2225

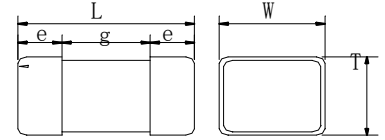

Type	L (mm)	W (mm)	e (mm)	g min (mm)	T (mm)					
0402	1.00±0.05	0.50±0.05	0.15~0.3	0.4	0.50±0.05	—	—	—	—	—
0603	1.60±0.10	0.80±0.10	0.2~0.5	0.5	0.80±0.10	—	—	—	—	—
0805	2.00±0.10	1.25±0.10	0.2~0.7	0.7	0.60±0.10	0.85±0.10	1.25±0.20	—	—	—
0805 ^{*1}	2.00±0.20 ^{*1}	1.25±0.20 ^{*1}	0.2~0.7	0.7	0.60±0.10	0.85±0.10	1.25±0.20	—	—	—
1206	3.20±0.20	1.60±0.20	0.3~0.8	1.6	0.85±0.10	1.00±0.10	1.25±0.20	1.60±0.20	—	—
1206 ^{*1}	3.20±0.30 ^{*1}	1.60±0.30 ^{*1}	0.3~0.8	1.6	0.85±0.10	1.00±0.10	1.25±0.20	1.60±0.30 ^{*1}	—	—
1210	3.20±0.30	2.5±0.20	0.3~0.8	1.6	0.85±0.10	1.25±0.20	1.60±0.20	2.00±0.20	2.50±0.30	—
1210 ^{*1}	3.20±0.40 ^{*1}	2.5±0.30 ^{*1}	0.3~0.8	1.6	0.85±0.10	1.25±0.20	1.60±0.20	2.00±0.20	2.50±0.30	—
1808	4.50±0.30	2.0±0.20	0.3~1.5	2.5	1.25±0.20	1.60±0.20	—	—	—	—
1808 ^{*1}	4.50±0.40 ^{*1}	2.0±0.25 ^{*1}	0.3~1.5	2.5	1.25±0.20	1.60±0.20	—	—	—	—
1812	4.50±0.30	3.2±0.30	0.3~1.5	2.5	0.85±0.10	1.00±0.10	1.25±0.20	1.60±0.20	2.00±0.20	2.50±0.30
1812 ^{*1}	4.50±0.40 ^{*1}	3.2±0.40 ^{*1}	0.3~1.5	2.5	0.85±0.10	1.00±0.10	1.25±0.20	1.60±0.20	2.00±0.20	2.50±0.30
2220	5.70±0.40	5.0±0.40	0.3~1.1	3.5	1.00±0.10	1.25±0.20	1.60±0.20	2.00±0.20	2.50±0.30	—
2225	5.70±0.40	6.4±0.40	0.3~1.1	3.5	1.00±0.10	2.00±0.20	2.50±0.30	—	—	—

^{*1} means the capacitance of this products is bigger than 1uF.

6. Specification and Test Condition

6.1 Appearance

Dielectrics	Specification	Testing Condition
COG/X7R/X5R/Y5V	No defects or abnormalities	Visual inspection.

6.2 Dimensions

Dielectrics	Specification	Testing Condition
COG/X7R/X5R/Y5V	Within the specified dimensions	Using calipers on micrometer

6.3 Capacitance

Dielectrics	Specification	Testing Condition
COG	Within the specified tolerance A: $\pm 0.05\text{pF}$; B: $\pm 0.1\text{pF}$; C: $\pm 0.25\text{pF}$; D: $\pm 0.5\text{pF}$; J: $\pm 5\%$	$1.0 \pm 0.2\text{Vrms}$, $1\text{MHz} \pm 10\%$ ($C > 1000\text{pF}$, $1.0 \pm 0.2\text{Vrms}$, $1\text{KHz} \pm 10\%$,)
X7R/X5R	Within the specified tolerance J: $\pm 5\%$; K: $\pm 10\%$; M: $\pm 20\%$	$1.0 \pm 0.2\text{Vrms}$, $1\text{KHz} \pm 10\%$ ($C_p > 10\mu\text{F}$, $0.5 \pm 0.1\text{Vrms}$, $120 \pm 24\text{Hz}$)
Y5V	Within the specified tolerance M: $\pm 20\%$; Z: -20% , $+80\%$	$1.0 \pm 0.2\text{Vrms}$, $1\text{KHz} \pm 10\%$ ($C_p > 10\mu\text{F}$, $0.5 \pm 0.1\text{Vrms}$, $120 \pm 24\text{Hz}$)
Test temperature: $25^\circ\text{C} \pm 3^\circ\text{C}$, test humidity: $< 70\% \text{RH}$.		

6.4 Dissipation Factor

Dielectrics	Specification	Testing Condition
COG	$C_p < 30\text{pF}$, $Q \geq 400 + 20C_p$; $C_p \geq 30\text{pF}$, $Q \geq 1000$	$1.0 \pm 0.2V_{\text{rms}}$, $1\text{MHz} \pm 10\%$, 25°C ($C_p > 1000\text{pF}$, $1.0 \pm 0.2V_{\text{rms}}$, 1KHz $z \pm 10\%$)
X7R/X5R	$U_R \geq 100\text{V}$, $DF \leq 3.5\%$ $25\text{V} \leq U_R \leq 50\text{V}$, $DF \leq 3.5\%$ $\leq 5.0\%$, (0402 ≥ 333 , 0603 ≥ 224 , 0805 ≥ 684 , 1206 > 225 , 1210 ≥ 475) $\leq 7\%$ (0603 ≥ 334 , 0805 ≥ 106 , 1206 ≥ 475) $U_R = 16\text{V}$, $DF \leq 5.0\%$ $\leq 7\%$, (0402 ≥ 104 , 0603 ≥ 564 , 0805 ≥ 105 , 1206 ≥ 475 , 1210 ≥ 106); $\leq 10.0\%$, (0402 ≥ 104 , 0603 ≥ 684 , 0805 ≥ 105 , 1206 ≥ 475 , 1210 ≥ 106); $U_R = 10\text{V}$, $DF \leq 7.0\%$ $DF \leq 10\%$ (0402 $\geq 1\mu\text{F}$, 0603 $\geq 2.2\mu\text{F}$, 0805 $\geq 4.7\mu\text{F}$, 1206 $\geq 10\mu\text{F}$, 1210 $\geq 22\mu\text{F}$) $U_R = 6.3\text{V}$, $DF \leq 10\%$	$1.0 \pm 0.2V_{\text{rms}}$, $1\text{KHz} \pm 10\%$, ($C_p > 10\mu\text{F}$, $0.5 \pm 0.1V_{\text{rms}}$, $120 \pm 24\text{Hz}$)
Y5V	$U_R \geq 50\text{V}$, $DF \leq 7.0\%$ $U_R = 25\text{V}$, $DF \leq 7.0\%$ (0402 $\geq 0.047\mu\text{F}$, 0603 $\geq 0.1\mu\text{F}$, 0805 $\geq 0.33\mu\text{F}$, 1206 $\geq 0.68\mu\text{F}$, 1210 $\geq 1\mu\text{F}$) $DF \leq 9.0\%$ (0402 $\geq 0.068\mu\text{F}$, 0603 $\geq 0.47\mu\text{F}$, 0805 $\geq 1\mu\text{F}$, 1206 $\geq 4.7\mu\text{F}$, 1210 $\geq 10\mu\text{F}$) $U_R = 16\text{V}$, $DF \leq 9.0\%$ $\leq 12.5\%$ (0402 ≥ 224 , 0603 ≥ 225 , 0805 ≥ 335 , 1206 ≥ 106 , 1210 ≥ 226 , 1812 ≥ 476) $U_R = 10\text{V}$, $DF \leq 12.5\%$ $U_R = 6.3\text{V}$, $DF \leq 15.0\%$	$1.0 \pm 0.2V_{\text{rms}}$, $1\text{KHz} \pm 10\%$, ($C_p > 10\mu\text{F}$, $0.5 \pm 0.1V_{\text{rms}}$, $120 \pm 24\text{Hz}$) at 25°C , 48hrs after annealing
Test temperature: $25^\circ\text{C} \pm 3^\circ\text{C}$, test humidity: $< 70\% \text{RH}$.		

6.5 Insulation Resistance

Dielectrics	Specification	Testing Condition
COG/X7R/ X5R/Y5V	$U_R \leq 50\text{V}$, More than $10\text{G}\Omega$ or $500\Omega\cdot\text{F}$, whichever is smaller.	$U_R \leq 50\text{V}$ $U_{\text{测}} = U_R$; Charge Time: $60 \pm 5\text{sec}$ Temperature: 25°C
COG/X7R	$U_R > 50\text{V}$, More than $4\text{G}\Omega$ or $100\Omega\cdot\text{F}$, whichever is smaller.	$U_R \leq 400\text{V}$ $U_{\text{测}} = U_R$ $U_R > 400\text{V}$ $U_{\text{测}} = 400\text{V}$; Charge Time: $60 \pm 5\text{sec}$ Temperature: 25°C
Test temperature: $25^\circ\text{C} \pm 3^\circ\text{C}$, test humidity: $< 70\% \text{RH}$.		

6.6 Dielectric Strength

Dielectrics	Rated voltage range	Measuring Method
COG	$U_R \leq 50V$	Force 300% Rated voltage for 5second. Max..current should not exceed 50 mA.
X7R/X5R/Y5V	$U_R \leq 50V$	Force 250% Rated voltage for 5second. Max..current should not exceed 50 mA.
COG/X7R	$100V \leq U_R < 500V$	Force 200% Rated voltage for 5second. Max..current should not exceed 50 mA.
	$500V \leq U_R < 1000V$	Force 150% Rated voltage for 5second. Max..current should not exceed 50 mA.
	$1000V \leq U_R < 2000V$	Force 150% Rated voltage for 5second. Max..current should not exceed 50 mA.
	$U_R \geq 2000V$	Force 120% Rated voltage for 5second. Max..current should not exceed 30 mA.

6.7 Temperature Coefficient of Capacitance

Dielectrics	Specification	Testing Condition																						
COG	Temperature coefficient within $\pm 30\text{ppm}/^\circ\text{C}$; Cp drift within $\pm 0.2\%$ or $\pm 0.05\text{pF}$	Measure capacitance under follow table list temperature:																						
		<table border="1"> <thead> <tr> <th>STEP</th> <th>COG, X7R</th> <th>X5R</th> <th>Y5V</th> </tr> </thead> <tbody> <tr> <td>1</td> <td>25 ± 2</td> <td>25 ± 2</td> <td>25 ± 2</td> </tr> <tr> <td>2</td> <td>-55 ± 3</td> <td>-55 ± 3</td> <td>-30 ± 3</td> </tr> <tr> <td>3</td> <td>25 ± 2</td> <td>25 ± 2</td> <td>25 ± 2</td> </tr> <tr> <td>4</td> <td>125 ± 3</td> <td>85 ± 3</td> <td>85 ± 3</td> </tr> <tr> <td>5</td> <td>25 ± 2</td> <td>25 ± 2</td> <td>25 ± 2</td> </tr> </tbody> </table>	STEP	COG, X7R	X5R	Y5V	1	25 ± 2	25 ± 2	25 ± 2	2	-55 ± 3	-55 ± 3	-30 ± 3	3	25 ± 2	25 ± 2	25 ± 2	4	125 ± 3	85 ± 3	85 ± 3	5	25 ± 2
STEP	COG, X7R	X5R	Y5V																					
1	25 ± 2	25 ± 2	25 ± 2																					
2	-55 ± 3	-55 ± 3	-30 ± 3																					
3	25 ± 2	25 ± 2	25 ± 2																					
4	125 ± 3	85 ± 3	85 ± 3																					
5	25 ± 2	25 ± 2	25 ± 2																					
X7R/X5R	Capacitance change within $\pm 15\%$																							
Y5V	Capacitance change within +22%, -82%	<p>1) COG The capacitance drift is calculated by dividing the differences between the maximum and minimum measured values in the step 1,3 and 5. The temperature coefficient is determined using the Capacitance measured in step 3 as a reference.</p> <p>2) X7R 、 X5R and Y5V The ranges of capacitance change compared within the above 25$^\circ\text{C}$ value over the temperature ranges shall be within the specified ranges.</p>																						

6.8 Adhesion

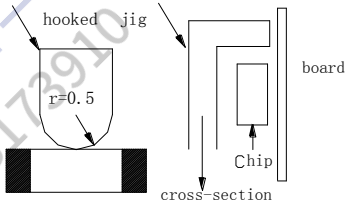
Dielectrics	Specification	Testing Condition
COG/X7R/X5R/ Y5V	No removal of the terminations or other defect shall occur.	<p>The pressurizing force shall be 6N (=600g*f) and the duration of application shall be 10±1sec.</p> 

6.9 Solderability of Termination

Dielectrics	Specification	Testing Condition
COG X7R/X5R Y5V	95% min. coverage of both terminal electrodes and less than 5% have pin holes or rough spots.	<p>Solder temperature: 245±5°C Dipping time: 2±1 seconds. Completely soak both terminal electrodes in solder</p>

6.10 Resistance to leaching

Dielectrics	Specification	Testing Condition
COG X7R/X5R Y5V	<p>95% min. coverage of both terminal electrodes and less than 5% have pin holes or rough spots. No remarkable visual damage.</p>	<p>Solder temperature: 270±5°C preheated: 120°C~150°C/60sec Dipping time: 10±1 seconds. Completely soak both terminal electrodes in solder</p>

6.11 Bending

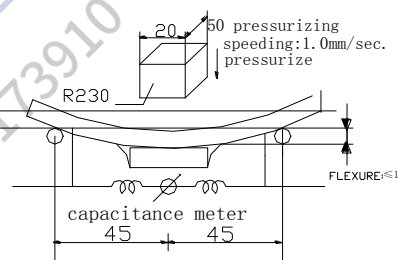
Dielectrics	Specification	Testing Condition
COG	No remarkable visual damage Cp change $\leq \pm 5\%$ or ≤ 0.5 pF	<p>Solder the capacitor on testing substrate and put it on testing stand. The middle part of substrate shall successively be pressurized by pressuring rod at a rated of about 1.0mm/sec. Until the deflection become means of the 1.0mm.</p> 
X7R/X5R	No remarkable visual damage Cp change $\leq \pm 10\%$	
Y5V	No remarkable visual damage Cp change $\leq \pm 30\%$	

6.12 Resistance to Soldering Heat

Dielectrics	Specification	Testing Condition
COG	No remarkable visual damage Cp change within $\pm 2.5\%$ or $\pm 0.25\text{pF}$, whichever is larger. DF meets initial standard value. IR meets initial standard value.	Soldering temperature: $270 \pm 5^\circ\text{C}$ Preheating: $120 \sim 150^\circ\text{C}$ 60sec. Dipping time: 10 ± 1 seconds. Measurement to be made after being kept at room temperature for 24 ± 2 (COG) or 48 ± 4 (X7R, X5R, Y5V) hours. Recovery for the following period under the standard condition after test. *Initial measurement for high dielectric constant type Perform a heat treatment at $140 \sim 150^\circ\text{C}$ for 1hr and let sit for 48 ± 4 hrs at room temperature. Perform the initial measurement.
X7R/X5R	No remarkable visual damage Cp change within $\pm 7.5\%$ DF meets initial standard value. IR meets initial standard value.	
Y5V	No remarkable visual damage Cp change within $\pm 20\%$ DF meets initial standard value. IR meets initial standard value.	

6.13 Temperature Cycle

Dielectrics	Specification	Testing Condition															
COG	No remarkable visual damage Cp change within $\pm 2.5\%$ or $\pm 0.25\text{pF}$, whichever is larger.	To perform 5 cycles of the stated environment <table border="1"> <thead> <tr> <th>Step</th> <th>Temperature</th> <th>Time</th> </tr> </thead> <tbody> <tr> <td>1</td> <td>Min. operating Temp. $+0/-3^{\circ}\text{C}$</td> <td>30min</td> </tr> <tr> <td>2</td> <td>25°C</td> <td>2~3 min</td> </tr> <tr> <td>3</td> <td>Max. operating Temp. $+3/-0^{\circ}\text{C}$</td> <td>30 min</td> </tr> <tr> <td>4</td> <td>25°C</td> <td>2~3 min</td> </tr> </tbody> </table>	Step	Temperature	Time	1	Min. operating Temp. $+0/-3^{\circ}\text{C}$	30min	2	25°C	2~3 min	3	Max. operating Temp. $+3/-0^{\circ}\text{C}$	30 min	4	25°C	2~3 min
Step	Temperature	Time															
1	Min. operating Temp. $+0/-3^{\circ}\text{C}$	30min															
2	25°C	2~3 min															
3	Max. operating Temp. $+3/-0^{\circ}\text{C}$	30 min															
4	25°C	2~3 min															
X7R/X5R	No remarkable visual damage Cp change within $\pm 7.5\%$	Measurement to be made after being kept at room temperature for 24 ± 2 hrs (COG) or 48 ± 4 hrs (X7R, X5R, Y5V) at room temperature, then measure. *Initial measurement for high dielectric constant type Perform a heat treatment at $140\sim 150^{\circ}\text{C}$ for 1hr and let sit for 48 ± 4 hrs at room temperature.															
Y5V	No remarkable visual damage Cp change within $\pm 20\%$	Perform the initial measurement.															

6.14 Moisture Resistance ,steady state

Dielectrics	Specification	Testing Condition
COG	<p>No remarkable visual damage Cp change within $\pm 5\%$ or $\pm 0.5\text{pF}$, whichever is larger. Cp<10pF, Q\geq200+10Cp; 10\leqCp<30pF, Q\geq275+2.5Cp Cp\geq30pF, Q\geq350 R*C\geq1000MΩ or 50Ω·F, whichever is smaller</p>	<p>Test temperature: 40\pm2$^{\circ}$C Humidity: 90~95% RH Testing time: 500 \pm12hrs</p> <p>Measurement to be made after being kept at room temperature for 24\pm2hrs (COG) or 48\pm4hrs (X7R, X5R, Y5V)</p> <p>*Initial measurement for high dielectric constant type Perform a heat treatment at 140~150$^{\circ}$C for 1hr and let sit for 48\pm4hrs at room temperature. Perform the initial measurement.</p>
X7R/X5R	<p>Cp change within $\pm 12.5\%$ DF:Not more than 2 times of initial value R*C\geq1000MΩ or 50Ω·F, whichever is smaller</p>	
Y5V	<p>No remarkable visual damage Cp change within $\pm 30\%$ DF:Not more than 1.5 times of initial value R*C\geq1000MΩ or 50Ω·F, whichever is smaller</p>	

6.15 Damp heat with load

Dielectrics	Specification	Testing Condition
COG	No remarkable visual damage Cp change $\leq \pm 7.5\%$ or $\pm 0.75\text{pF}$, whichever is larger. Cp $< 30\text{pF}$, Q $\geq 100 + 10/3 * \text{Cp}$ Cp $\geq 30\text{pF}$, Q ≥ 200 R*C $\geq 500\text{M}\Omega$ or $25\Omega \cdot \text{F}$, whichever is smaller	Test temperature: $40 \pm 2^\circ\text{C}$ Humidity: 90~95% RH Voltage: 100% of the rated voltage Testing time: $500 \pm 12\text{hrs}$ Measurement to be made after being kept at room temperature for $24 \pm 2\text{hrs}$ (COG) or $48 \pm 4\text{hrs}$ (X7R, X5R, Y5V)
X7R/X5R	No remarkable visual damage Cp change $\leq \pm 12.5\%$ DF: Not more than 2 times of initial value R*C $\geq 500\text{M}\Omega$ or $25\Omega \cdot \text{F}$, whichever is smaller	*Apply the rated DC voltage for 1 hour at $40 \pm 2^\circ\text{C}$. Remove and let sit for $48 \pm 4\text{hrs}$ at room temperature. Perform the initial measurement.
Y5V	No remarkable visual damage Cp change $\leq \pm 30\%$ DF: Not more than 1.5 times of initial value R*C $\geq 500\text{M}\Omega$ or $25\Omega \cdot \text{F}$, whichever is smaller	
This test is only suitable for general products, it is not suitable for mid-high voltage products.		

6.16 Life Test

Dielectrics	Specification	Testing Condition
COG	No remarkable visual damage Cp change $\leq \pm 3\%$ or $\pm 0.3\text{pF}$, whichever is larger. $Q \geq 350$ ($C_p \geq 30\text{ PF}$) $Q \geq 275 + (2.5 * C_p)$ ($10\text{ pF} \leq C_p < 30\text{ PF}$) $Q \geq 200 + 10 * C_p$ ($C_p < 10\text{ PF}$) $R * C \geq 1000\text{M}\Omega$ or $50\Omega \cdot \text{F}$, whichever is smaller	Test temperature: Max. Operating Temp. $\pm 3^\circ\text{C}$ Voltage: $UR < 100\text{V}$ 150% of the rated voltage $100\text{V} \leq UR < 500\text{V}$ 130% of the rated voltage $500\text{V} \leq UR < 1000\text{V}$ 120% of the rated voltage $1000\text{V} \leq UR$ 100% of the rated voltage Testing time: 1000 hrs Measurement to be made after being kept at room temperature for $24 \pm 2\text{hrs}$ (COG) or $48 \pm 4\text{hrs}$ (X7R, X5R, Y5V) *Initial measurement for high dielectric constant type Apply 200% of the rated DC voltage for one hour at the maximum operating temperature $\pm 3^\circ\text{C}$. Remove and let sit for $48 \pm 4\text{hrs}$ at room temperature. Perform the initial measurement
X7R/X5R	No remarkable visual damage Cp change $\leq \pm 12.5\%$ DF: Not more than 2 times of initial value $R * C \geq 1000\text{M}\Omega$ or $50\Omega \cdot \text{F}$, whichever is smaller	Remove and let sit for $48 \pm 4\text{hrs}$ at room temperature. Perform the initial measurement
Y5V	No remarkable visual damage Cp change $\leq \pm 30\%$ DF: Not more than 1.5 times of initial value $R * C \geq 1000\text{M}\Omega$ or $50\Omega \cdot \text{F}$, whichever is smaller	
This test is only suitable for general products, it is not suitable for mid-high voltage products.		

7. Packing

7.1 Bulk Packing

Standard packing 10Kpcs/bag; others are according to customer request.

7.2 Tape Packing

Type	Dimensions Size (mm)			(pcs/reel)	
	L	W	T	Paper Tape	Plastic Tape
0402	1.0	0.5	0.5	10,000	N/A
0603	1.6	0.8	0.8	4,000	N/A
0805	2.0	1.25	< 0.85	4,000	N/A
			≥ 0.85	N/A	2,000 (or 3000)
1206	3.2	1.6	≤ 0.85	4,000	N/A
			> 0.85	N/A	2,000 (or 3000)
1210	3.2	2.5	≤ 1.25	N/A	3,000
			> 1.25	N/A	2,000
1808	4.5	2.0	≤ 1.25	N/A	1,000
1812	4.6	3.2	≤ 1.25	N/A	1,000
			> 1.25	N/A	
2220	5.7	5.0	≤ 1.25	N/A	1,000
			> 1.25	N/A	700
2225	5.7	6.4	> 1.25	N/A	700

7.2.1 Dimensions of Packing Paper

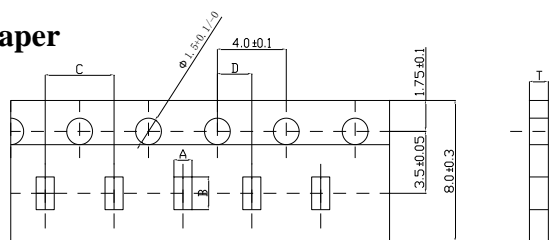

Type	A	B	C	D	T
0402	0.65 ± 0.10	1.15 ± 0.10	2.0 ± 0.05	2.0 ± 0.05	0.8max
0603	1.05 ± 0.10	1.85 ± 0.10	4.0 ± 0.10	2.0 ± 0.10	1.1max
0805	1.55 ± 0.15	2.3 ± 0.15	4.0 ± 0.10	2.0 ± 0.10	1.1max
1206	1.95 ± 0.15	3.5 ± 0.15	4.0 ± 0.10	2.0 ± 0.10	1.1max

(unit: mm)

7.2.2 Dimensions Dimensions of Embossed Packing

8mm宽, 4mm间距编带

12mm宽, 8mm/4mm间距编带

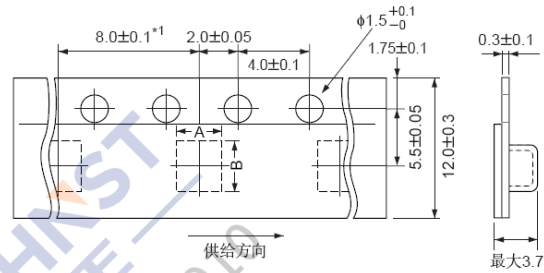
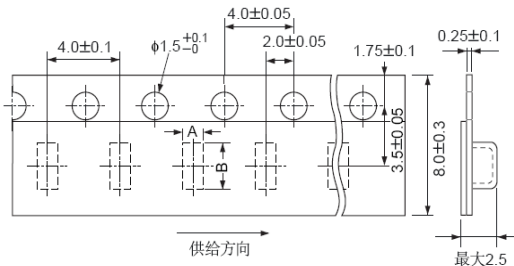

A: 1.45 ± 0.20	B: 2.25 ± 0.20	(0805)	A: 1.95 ± 0.20	B: 3.50 ± 0.20	(1206)
A: 2.90 ± 0.20	B: 3.60 ± 0.20	(1210)	A: 2.50 ± 0.20	B: 4.90 ± 0.20	(1808)
A: 3.60 ± 0.20	B: 4.90 ± 0.20	(1812)	A: 5.40 ± 0.20	B: 6.10 ± 0.20	(2220)
A: 6.10 ± 0.20	B: 6.80 ± 0.20	(2225)			

(unit: mm)

7.2.3 Dimensions Dimensions of Reel

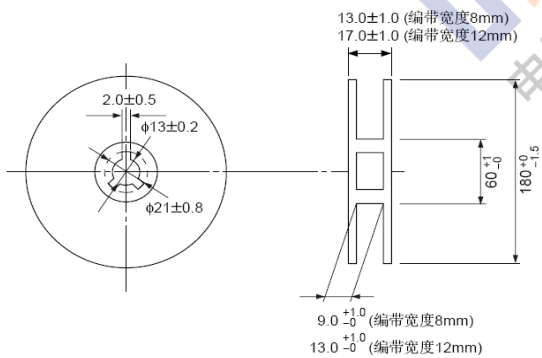

7.2.4 Taping Figure

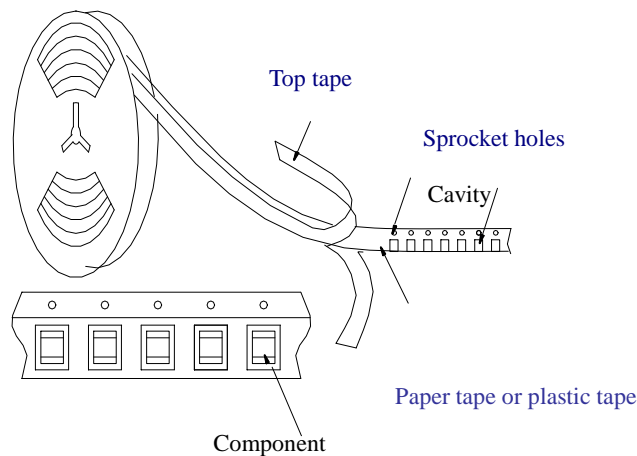

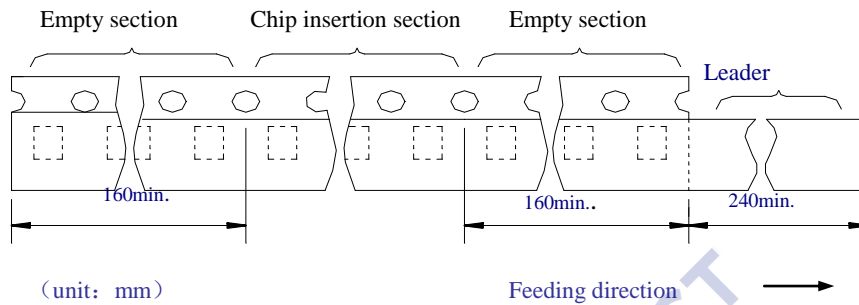

7.2.5 Taping Method

- ① Tapes for capacitors are wound clockwise. The sprocket holes are to the right as the tape is pulled toward the user.
- ② The top tape and base tape are not attached at the end of the tape for a minimum of 5 pitches.
- ③ Part of the leader and part of the empty tape shall be attached to the end of the tape as follows.
- ④ Missing capacitors number within 0.1% of the number per reel or 1pc, whichever is greater, and are not continuous.
- ⑤ The top tape and bottom tape shall not protrude beyond the edges of the tape and shall not cover sprocket holes.
- ⑥ Cumulative tolerance of sprocket holes, 10 pitches: $\pm 0.3\text{mm}$.
- ⑦ Peeling off force: 0.1 to 0.6N in the direction shown down.

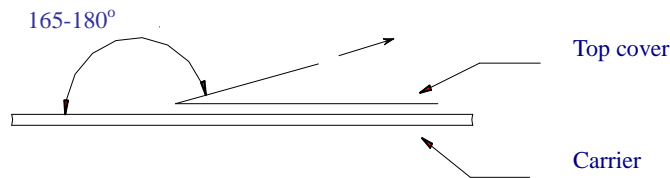

7.2.6 Reel Label

The Contents of Label

(1) CC 0603 X7R 104 K 500 C T
 ① ② ③ ④ ⑤ ⑥ ⑦ ⑧

① Code of Ceramic Capacitor

② Dimensions chip size, ③ dielectrics, ④ capacitance, ⑤ tolerance,

⑥ rated voltage, ⑦ thickness, ⑧ packing

(2) Lot. No.:005001A21401070811N

(3) Qty: 4000pcs

(4) RoHS:GREEN PARTS

7.2.7. Package

7.2.7.1 Carton

7.2.7.1.1 Dimensions Carton Size

L	W	H
40cm	36cm	20cm

7.2.7.1.2 Quantity: 240Kpcs /one carton

1 INNER BOX=40,000PCS

1 CARTON=40,000PCS × 6BOX=240,000PCS

RoHS according to customer request

7.2.7.2 Inner Box

7.2.7.2.1 DimensionsSize

L	W	H
18.5cm	6.5cm	19cm

7.2.7.2.2 Qty: 40Kpcs /BOX

1 REEL=4,000PCS

1 INNER BOX=4,000PCS × 10REEL =40,000PCS

DGPHNST
— 華年 —
电话: 0755-23173910

8. Precautions on the use of MLCC

8.1 PCB Design

8.1.1 Design of Land-patterns

The following diagrams and tables show some examples recommended patterns to prevent excessive solder amounts (larger fillets which above the component end terminations)

Examples of improper pattern designs are also shown.

Recommended land dimensions for a typical chip capacitor land patterns for PCBs

Recommended land dimensions for wave-soldering (unit: mm)

SIZE		0603	0805	1206
Dimen sions	L	1.6	2.0	3.2
	W	0.8	1.25	1.6
A		0.8~1.0	1.0~1.4	1.8~2.5
B		0.5~0.8	0.8~1.5	0.8~1.7
C		0.6~0.8	0.9~1.2	1.2~1.6

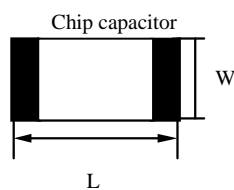
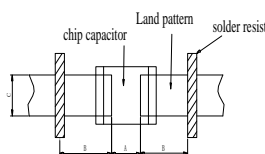

Recommended land dimensions for reflow-soldering (unit: mm)

SIZE		0402	0603	0805	1206	1210	1808	1812	2220	2225
Dimen sions	L	1.0	1.6	2.00	3.2	3.2	4.5	4.5	5.7	5.7
	W	0.5	0.8	1.25	1.6	2.5	2.0	3.2	5.0	6.4
A		0.35~0.45	0.6~0.8	0.8~1.2	1.8~2.5	1.8~2.5	2.5~3.4	2.5~3.4	4.0~4.6	4.0~4.6
B		0.40~0.50	0.6~0.8	0.8~1.2	1.0~1.5	1.0~1.5	1.8~2.0	1.8~2.0	2.0~2.2	2.0~2.2
C		0.45~0.55	0.6~0.8	0.9~1.6	1.2~2.0	1.6~3.2	1.4~1.8	2.3~3.5	3.5~4.8	5.0~6.2

Excess solder can affect the ability of chips to withstand mechanical stresses. Therefore, please take proper precautions when designing land-patterns.

Examples of good and bad solder application

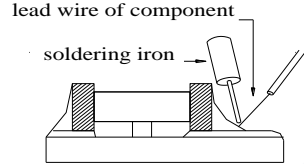
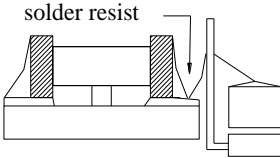
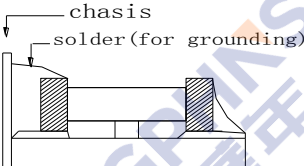
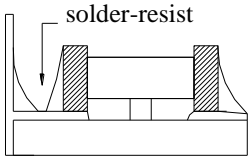
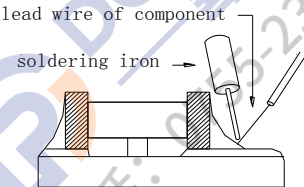
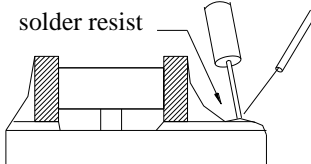
Item	Not recommended	Recommended
Mixed mounting of SMD and leaded component		
Component placement close to the chassis		
Hand-soldering of leaded components near mounted components		

8.1.2 Pattern configurations

The following are examples of good and bad capacitor layout, SMD capacitors should be located to minimize any possible mechanical stresses from board warp or deflection..

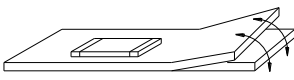
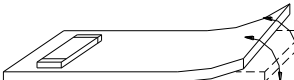
	Not recommended	Recommended
		

To layout the capacitors for the breakaway PC board, it should be noted that the amount of mechanical stresses given depending on capacitor layout. The example below shows recommendations for better design.

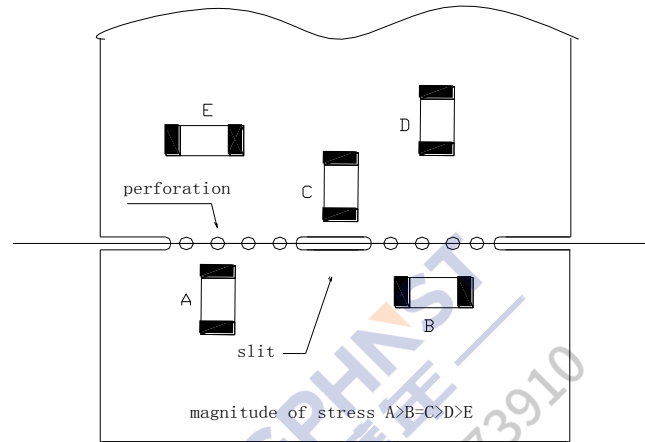

When breaking PC boards along their perforations, the amount of mechanical stress on the capacitors can vary according to the method used. The following methods are listed in order from least stressful to most stressful: push-back, slit, -grooving, and perforation. Thus, any ideal SMD capacitor layout must also consider the PCB splitting procedure.

8.2 Considerations for automatic placement

Adjustment of mounting machine

- ①. Excessive impact load should not be imposed on the capacitors when mounting the PC boards.
- ②. The maintenance and inspection of the mounters should be conducted periodically.

	Not recommended	Recommended
Single-sided mounting	<p>crack</p>	<p>supporting pin</p>
Double-sided mounting	<p>crack</p> <p>solder peeling</p> <p>crack</p>	<p>supporting pin</p>

8.3 Recommended soldering profile

8.3.1 Re: ①flow Soldering is recommended; ②flow soldering is suitable for bigger size MLCCs

8.3.2 Recommended Sn&Pb soldering profile

Reflow soldering

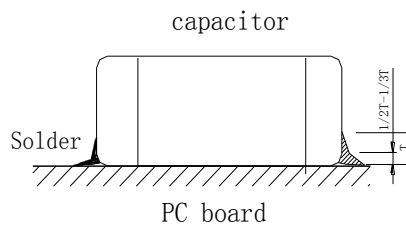
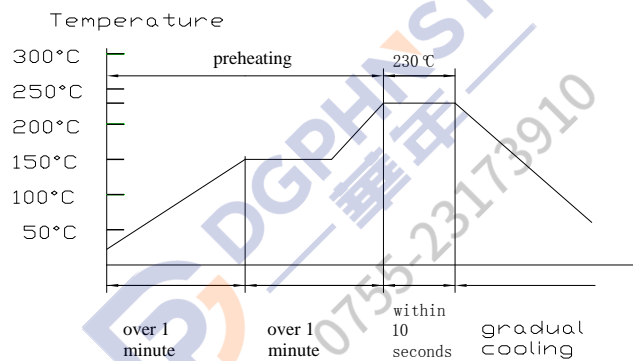

- ②. Because excessive dwell times can detrimentally affect solderability, soldering duration should be kept as close to recommended times as possible.

Wave solder profile

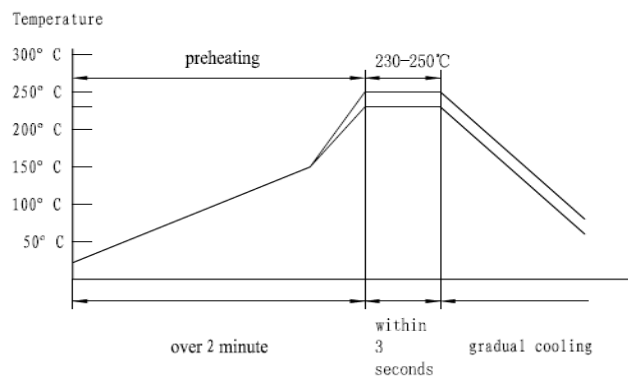

Caution

- ①. Make sure the capacitors are preheated sufficiently.
- ②. The temperature difference between the capacitor and melted solder should not be greater than 100 to 130°C.
- ①. Cooling after soldering should be gradual as possible.

Hand soldering

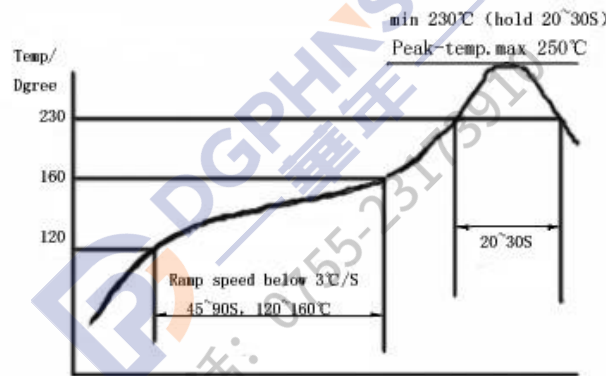

Caution

- ①. Use a 20w soldering iron with a maximum tip diameter of 1.0mm.
- ②. The soldering iron should not directly touch the capacitor.

8.3.3 Recommended Pb-Free soldering profile

Reflow solder

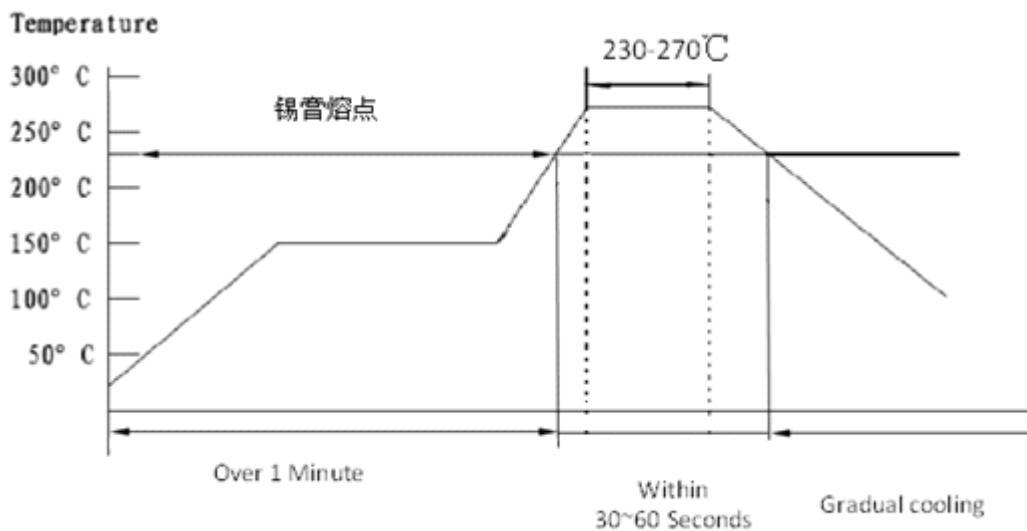

Wave solder profile

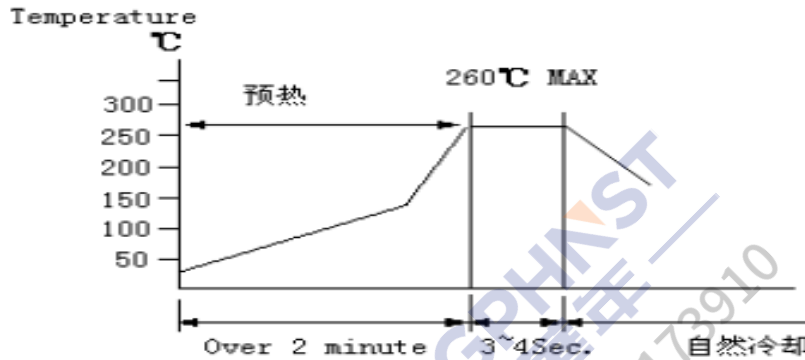

8.4 Handling

Breakaway PC boards (splitting along perforations)

- (1). When splitting the PC board after mounting capacitors and other components, care is required so as not to give any stresses of deflection or twisting to the board.
- (2). Board separation should not be done manually, but by using the appropriate devices.

8.5 Storage

- (1). Keep the storage environment conditions as following: Temperature: 5~40°C ; Humidity: ≤70% RH
- (2). Don't open the tape until the parts are to be used, and store them within one year since the date printed on the reel.
- (3). Use the chips within 3 months after the tape is opened.
- (4). The capacitance value of high dielectric constant capacitors (X7R,X5R,Y5V) will gradually decrease with the passage of time, so this should be taken into consideration in the circuit design. If such a capacitance reduction occurs, a heat treatment of 150°C for 1 hour will return the capacitance to its initial level.