

1. 適用範圍 / SCOPE

TCP 系列保險絲，適用於一般電子設備。
TCP series Fuse, used in electronic equipment.

2. 產品型號 / TYPE

例「example」：

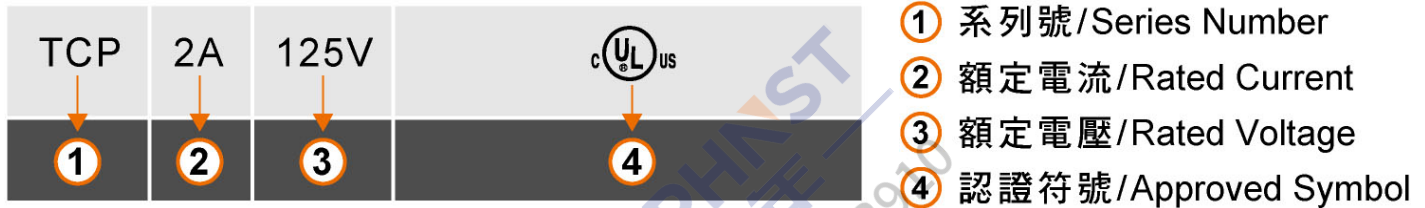

3. 額定電流和額定電壓 / RATED CURRENT AND RATED VOLTAGE

額定電流 / Rated Current:

160mA~6.3A

額定電壓 / Rated Voltage:

125V AC/DC

4. 標示 / MARKING

保險絲兩端銅帽上需有下列標示 / The fuses cap shall have the following marking:

① 製造工廠的標識 / Manufacture's Logo: 

② 額定電流 / Rated Current (A): __mA/ __A

注意 / Note :

對標示的大小和位置沒有規定 / Size and position of the markings shall not be provided.

5. 外觀及形狀 / APPEARANCES AND CONFIGURATION

5-1 外觀：外觀不應有顯著的汙點、鐵銹或裂紋

Appearances: There shall not be any remarkable stain, rust or crack on the appearances.

5-2 形狀：帶腳的超小型保險絲。

Configuration: Axial Leded Micro-Fuse

6. 工程圖和結構 / OUTLINE DRAWING AND STRUCTURE

6-1 工程圖 (單位 : mm) / Outline Drawing and Dimensions (Unit: mm)

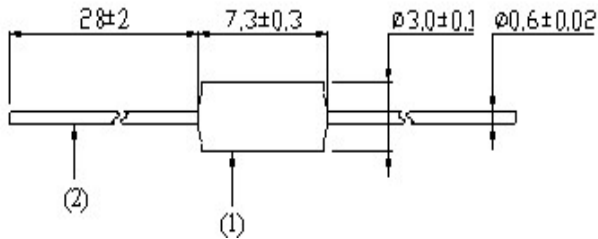

6-2 結構 / Structure

編號 No.	元件 Component	材質 Material	數量 Quantity
①	本體 Body	膠料 Plastic	1
②	端子 Termination	鍍錫銅線 Tinned Copper Wire	2

7. 產品特性 / PRODUCT CHARACTERISTICS

7-1 拉力測試 / Tensile test

軸向拉力 10 牛頓,持續 10±1 秒/ Pulling the cap of the fuse with 10N at axial direction keep 10±1sec.

7-2 推力測試 / Thrust test

軸向推力 2 牛頓,持續 10±1 秒/ Thrust two cap's bottom of the fuse with 2N at axial direction keep 10±1sec.

7-3 可焊性/ Solderability

波峰焊 Wave : 260°C · ≤3s.

烙鐵焊 Soldering Iron: 350±10°C · ≤3s.

7-4 耐焊接熱/Soldering heat resistance

波峰焊 Wave : 260°C · 10s.

烙鐵焊 Soldering Iron: 350°C · 5s.

8. 電氣特性 / ELECTRICAL CHARACTERISTICS

8-1 熔斷/電流特性 : Pre-Arcing Time / Current Characteristic

RATED CURRENT	2 IN	10 IN
160mA to 6.3A	Max.	Min.
	60 s	10 ms

8-2 產品規格/Specification

額定電流 Rated Current	冷電阻 Cold resistance	I ² T 值 I ² T Value (A ² Sec@8ms)
160mA	1.669Ω	0.0219
200mA	1.097Ω	0.0466
250mA	0.828Ω	0.0865
315mA	0.514Ω	0.208
400mA	0.321Ω	0.374
500mA	0.271Ω	0.417
630mA	0.202Ω	0.675
800mA	114.50mΩ	1.81
1A	91.65mΩ	2.250
1.25A	74.65mΩ	2.66
1.6A	53.25mΩ	3.610
2A	38.75mΩ	5.59
2.5A	31.35mΩ	8.620
3.15A	20.10mΩ	11.90
4A	16.70mΩ	18.10
5A	12.55mΩ	25.00
6.3A	7.15mΩ	46.60

8-3 時間電流曲線/Time-Current Curve

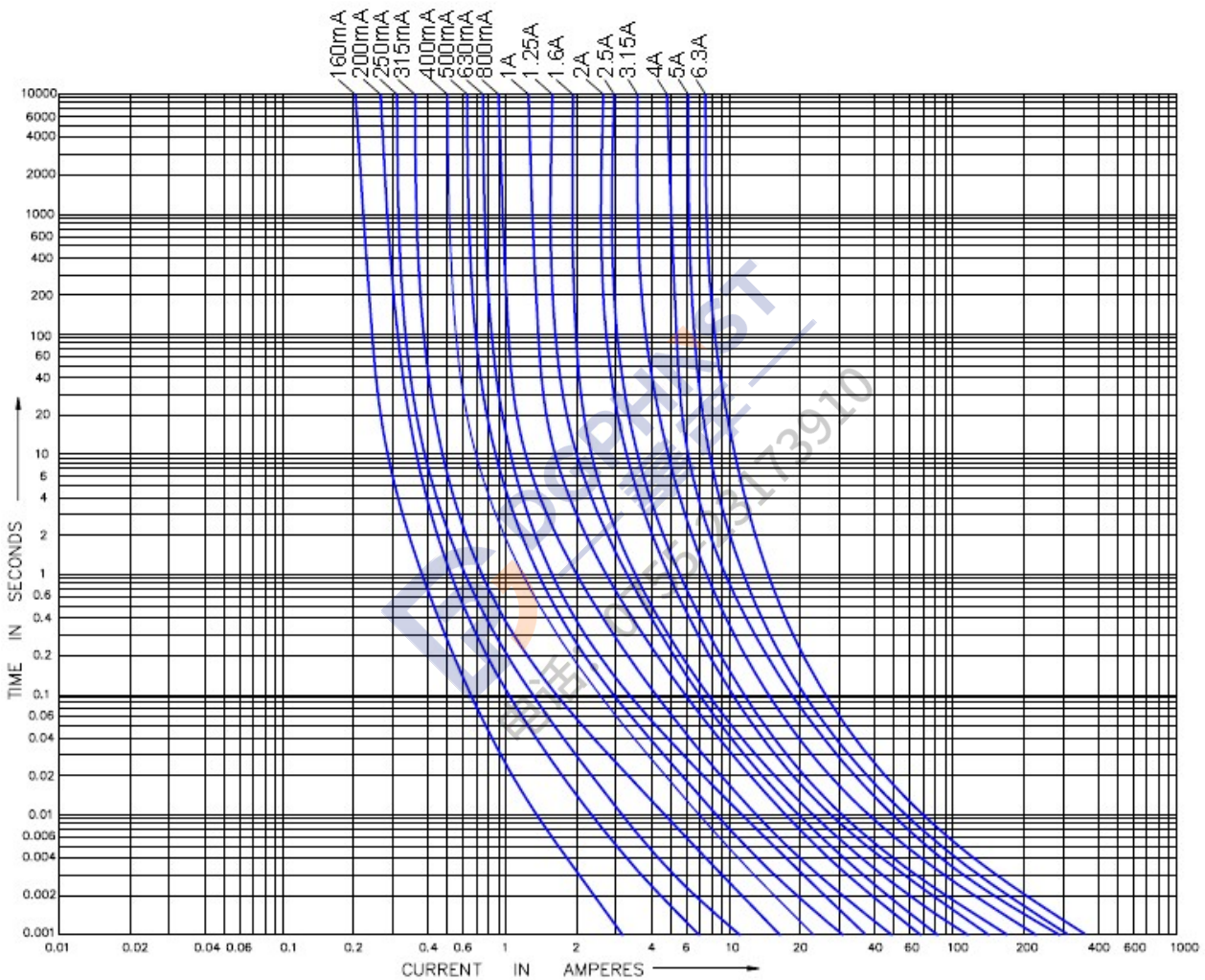

9. 環境特性 / ENVIRONMENTAL CHARACTERISTIC

9-1 操作溫度範圍: -55°C ~ 125°C / Operating Temperature: -55°C ~ 125°C。

若貴司操作環境溫度超出 $25 \pm 5^\circ\text{C}$ 範圍，在選用保險絲規格時，需考慮操作環境溫度對保險絲的影響。

請參照：溫度-電流曲線圖

When choosing the fuse's specification, if the operating environmental temperature beyond the scope from $20 \sim 30^\circ\text{C}$, you should consider the environmental temperature's affection to fuses.

Please refer: Temperature-Current curve

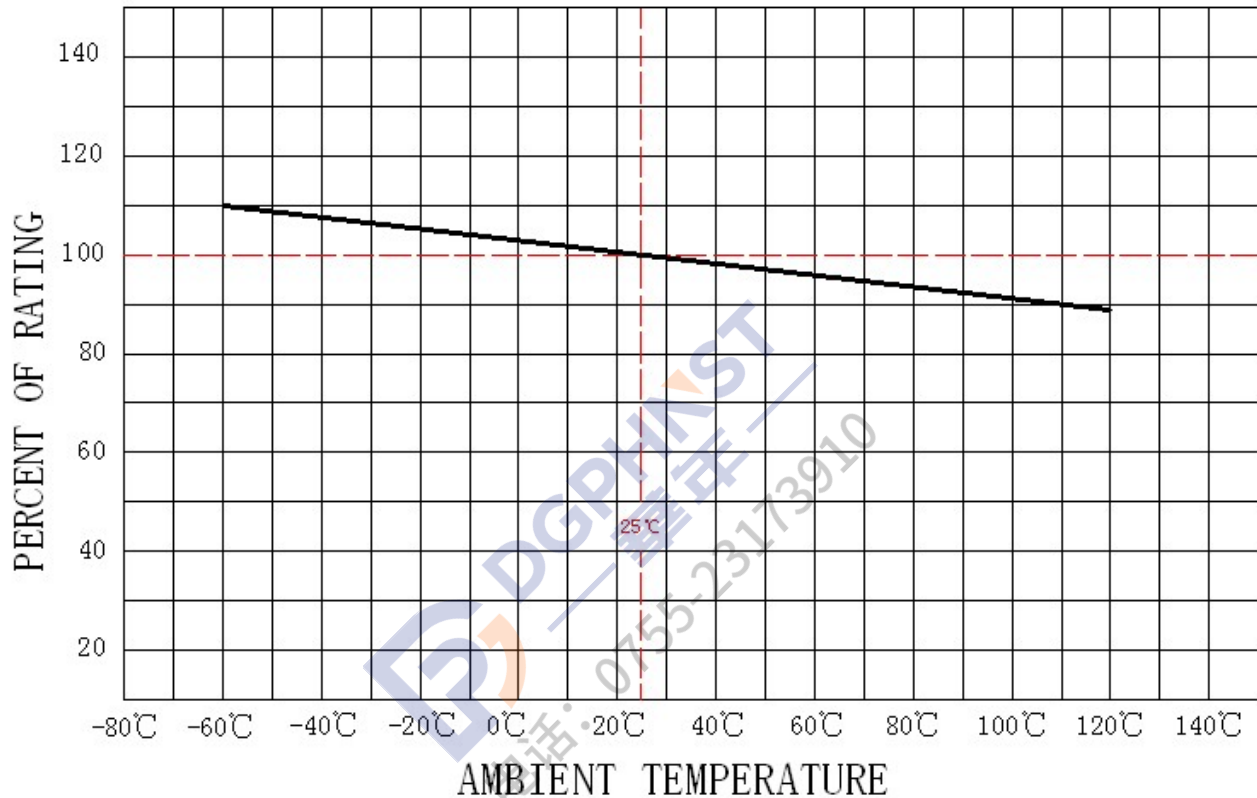

9-2 存儲條件 / Storage Conditions

在溫度+10°C ~ 60°C、相對濕度 $\leq 75\%$ 的密閉條件下可存放 3 年。

Under airtight in temperature+10°C ~ 60°C、relative humidity $\leq 75\%$ can store 3 years.

在溫度+10°C ~ 60°C、相對濕度為 95%的非露天下最多可存放 30 天。

Without dew in temperature+10°C ~ 60°C、relative humidity be 95% maximum value for 30days.

10. 安裝方式及條件 / INSTALLATION WAY AND PARAMETERS

10-1 建議如下圖安裝方式安裝，並滿足所要求的尺寸。

Propose that the following picture installation way is installed, and satisfied the required size.

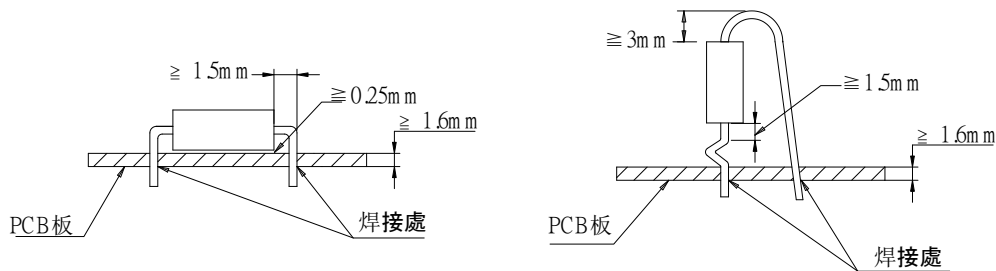

10-2 建議客戶焊接參數 / Recommended Customer Soldering Parameters.

波峰焊參數 / Wave Parameters

錫爐溫度 / Solder Pot Temperature: 260°C Max

焊接時間 / Solder Dwell Time: 2~5s

手工焊參數 / Hand-Solder Parameters

烙鐵溫度 / Solder Iron Temperature: 350±5°C

焊接時間 / Heating Time: 5s Max

11. 其他使用注意事項 / OTHER NOTICE IN USED

如果需在保險絲上加熱縮套管，烘烤溫度與時間需參照以下規定。

If need to add heat draws back the sleeve pipe on the fuse, it needs to consult the following regulation to toast temperature and time.

溫度 temperature	120°C	130°C	140°C	150°C
時間 time	Max 80s	Max 75s	Max 70s	Max 65s

12. 安全認證及編號 / STANDARDS AND APPROVALS

UL	E56092 (160mA~6.3A)
----	----------------------

13. 包裝 / PACKING

13-1 包裝數量 / Packing Quantity

A：每內盒裝 2000 個保險絲/ 2000pcs per inner box .

B：每外箱裝 10 內盒保險絲/10 inner boxes per outer box .

13-2 包裝尺寸圖/ Taping Configuration

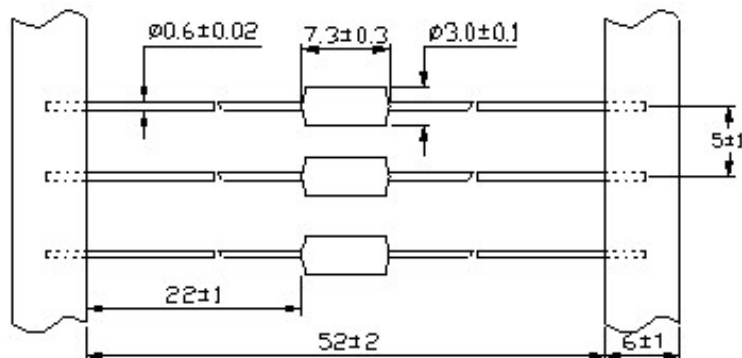

13-3 內包裝盒/Inner box of packing

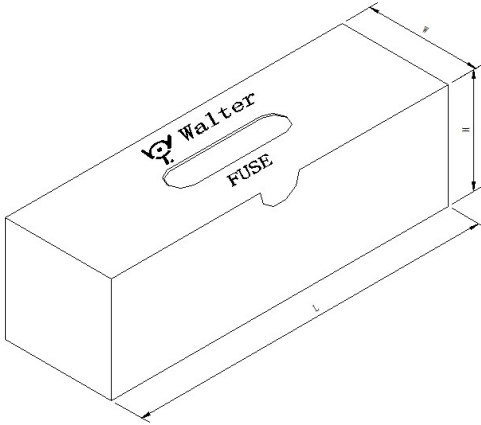

單位/Unit : mm

L	W	H
255±3	80±3	80±3

13-4 外包裝箱/ Outer box of packing

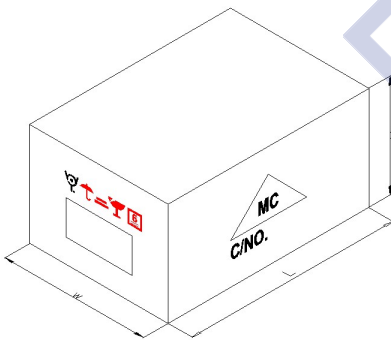

單位/Unit : mm

L	W	H
445±5	270±5	190±5

14. 其他 / OTHERS

14-1 如果在使用中有超出本規格書的要求，必須經由雙方協商確認。

In the event that an impropriety is found beyond this specification, it shall be fixed by mutual agreement between the parties.

14-2 如果本規格書有不適當的情況，必須通過雙方協商並由本公司修改。

In the event that an impropriety is found in this specification, SUZHOU WALTER ELECTRONIC CO., LTD. shall amend it by mutual agreement between the parties.

版次	製作	確認	審核
第6版	程正永 2022/02/28	饒紅 2022/02/28	Russel.Hsu 2022/3/1



UL iQ for Fuses



Fuses

E56092

Guide Information

SUZHOU WALTER ELECTRONIC CO LTD

NO.99 Xinli Road, Fenhu Technic Development Zone, Wujiang Jiangsu 215211 CN

TCP

Supplemental micro fuses: pigtail leads

<u>Size</u> mm(in)	<u>Amps</u> (A)	<u>Volts</u> (V)	<u>Interrupting</u> <u>Rating (A)</u>
3 x 7.3 (0.12 x 0.29)	0.16 - 6.3	125Vac	50
	0.16 - 6.3	125Vdc	50

Report Date: 2004-04-08

Last Revised: 2019-07-22

© 2019 UL LLC

