

1. 適用範圍 / SCOPE

WL25 系列，適用於純電動汽車、混合動力汽車及電氣設備的全範圍分斷熔斷器。
WL25 series, general purpose fuse for EV/HEV and electrical equipments.

2. 產品型號 / TYPE

例「example」：

WL25	20A	600V		①系列號/Series Number
↓	↓	↓	↓	②額定電流/rated Current
①	②	③	④	③額定電壓/Rated Voltage
				④安規符號/Approved Symbol

3. 額定電流和額定電壓/ RATED CURRENT AND RATED VOLTAGE

額定電流 / Rated Current: 2A~30A

額定電壓 / Rated Voltage: 600V AC/DC

4. 標示 / MARKING

保險絲上需有下列標示/The fuses shall have the following marking

製造工廠的標識+系列號/ Manufacture' s Logo+ Part Number:

額定電流+額定電壓/ Rated Current (A)+ Rated Voltage(V):

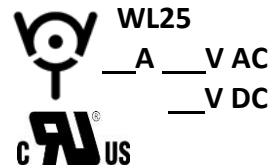

認證符號/ Approved Symbol

注意 / Note :

對標示的大小和位置沒有規定 / Size and position of the markings shall not be provided.

5. 外觀及形狀 / APPEARANCES AND CONFIGURATION

5-1 外觀：不應有破碎、明顯的污斑。

Appearances: There shall not be break up and any remarkable blotch.

5-2 螺栓安裝,提供其他安裝方式選擇

Stud-mount, optional for other installtion

6. 工程圖和結構 / OUTLINE DRAWING AND STRUCTURE
6-1 工程圖 (單位 : mm) / Outline Drawing and Dimensions (Unit: mm)

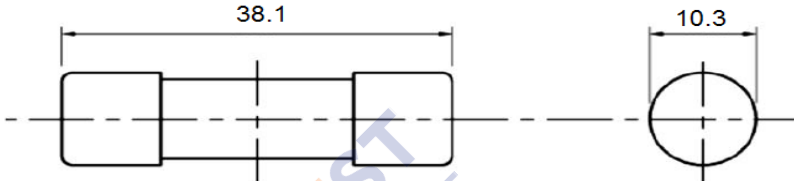
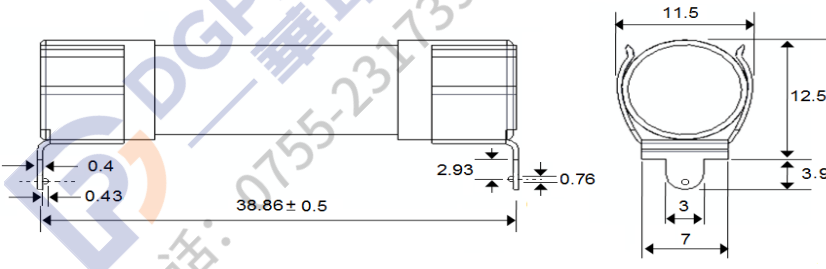
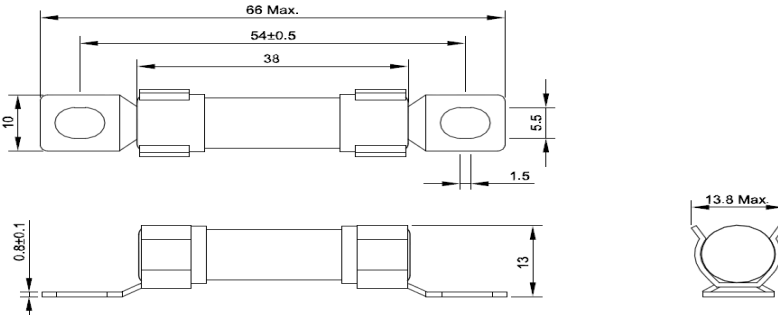
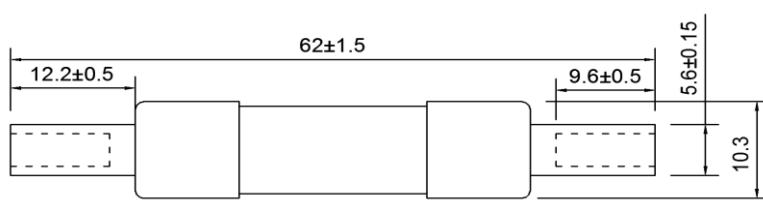
WL25-XXX	
WL25-XXX-P1	
WL25-XXX-BP	
WL25-XXX-I	 <p style="text-align: center;"> Note: for 10-12AWG (6-4mm²); Recommended Crimping Tool: T&B Sta-Kon ERG4002 or equivalent </p>

7. 電氣特性 / ELECTRICAL CHARACTERISTICS

% of Ampere Rating (A)	Operating	
	Min	Max
100%	14400	-
135%	-	3600
200%	-	120

說明/Specifications

品名 Part No	料號 Ordering P/N				I2t 值 Pre-arcing I2t A2sec	額定電流 Rated Current (A)	額定電壓 Rated Voltage AC/DC	分斷能力 Breaking Capacity
	WL25-XX	WL25- XX-P1	WL25- XX-BP	WL25- XX-I				
WL25	WL25-2	WL25-2-P1	WL25-2-BP	WL25-2-I	1.2	2A	600Vac 600Vdc	50KA
	WL25-3	WL25-3- P1	WL25-3- BP	WL25-3- I	3.6	3 A		
	WL25-4	WL25-4- P1	WL25-4- BP	WL25-4- I	9.5	4 A		
	WL25-5	WL25-5- P1	WL25-5- BP	WL25-5- I	20	5 A		
	WL25-6	WL25-6- P1	WL25-6- BP	WL25-6- I	30	6 A		
	WL25-8	WL25-8- P1	WL25-8- BP	WL25-8- I	85	8 A		
	WL25-10	WL25-10- P1	WL25-10- BP	WL25-10- I	30	10 A		
	WL25-12	WL25-12- P1	WL25-12- BP	WL25-12- I	100	12 A		
	WL25-15	WL25-15- P1	WL25-15- BP	WL25-15- I	150	15 A		
	WL25-20	WL25-20- P1	WL25-20- BP	WL25-20- I	230	20 A		
	WL25-25	WL25-25- P1	WL25-25- BP	WL25-25- I	400	25 A		
	WL25-30	WL25-30- P1	WL25-30- BP	WL25-30- I	1200	30 A		

備注：/Remark：

溫升：60%額定電流小於等於 50K

Temperature Rise：≤ 50K with 60% of rated current

弧前 I2t 典型值在 10 倍電流下測得

Typical pre-arcing I2t measured at 10In

8. 時間電流曲線 Time-Current Curve

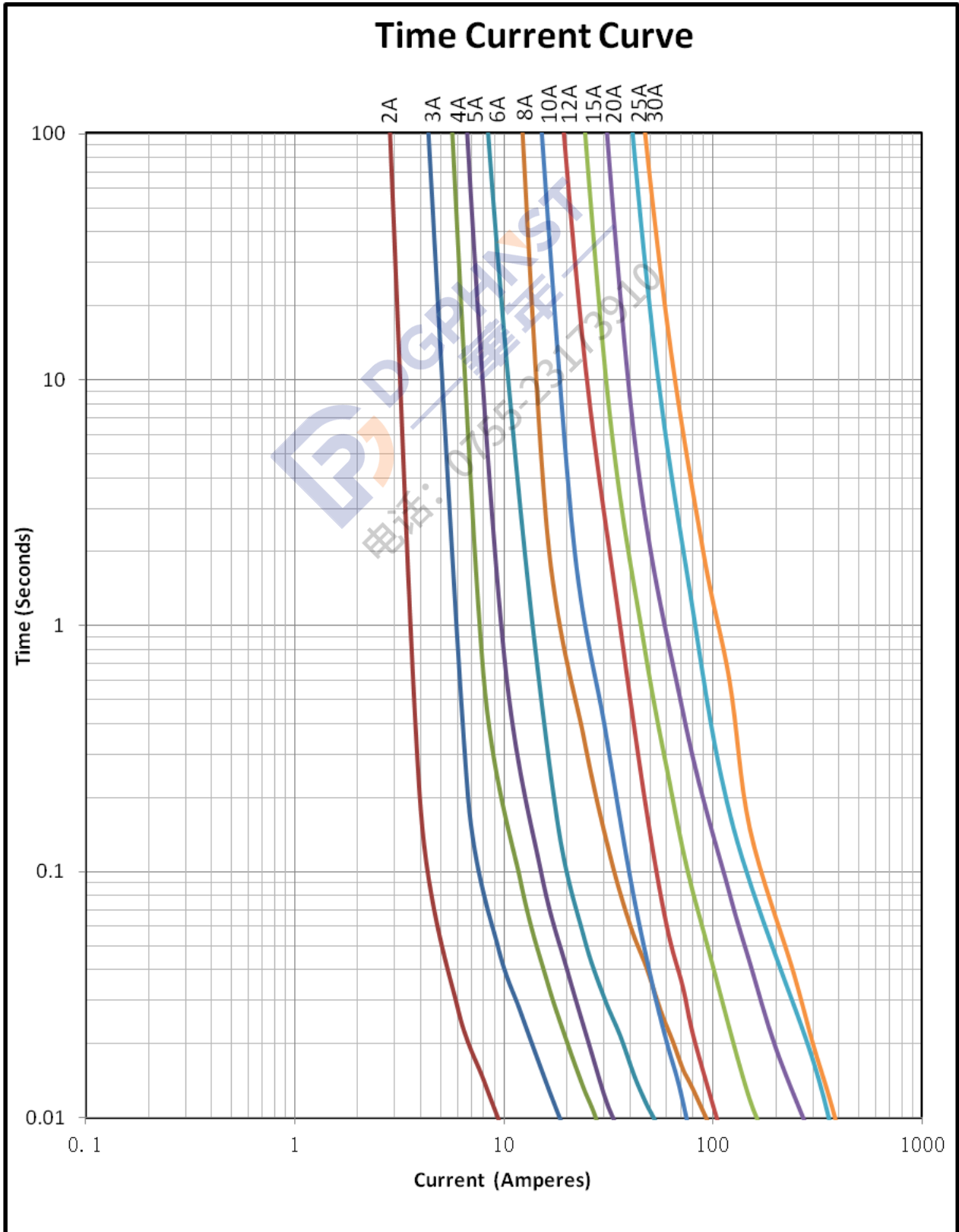

9. 環境特性 / ENVIRONMENTAL CHARACTERISTIC

9-1 操作溫度範圍: -55°C ~ 125°C / Operating Temperature: -55°C ~ 125°C

若貴司操作環境溫度超出25±5°C範圍，在選用保險絲規格時，需考慮操作環境溫度對保險絲的影響。請參照：溫度-電流曲線圖。

When choosing the fuse's specification, if the operating environmental temperature beyond the scope from 20~30°C, you should consider the environmental temperature's affection to fuses.

Please refer : Temperature-Current curve:

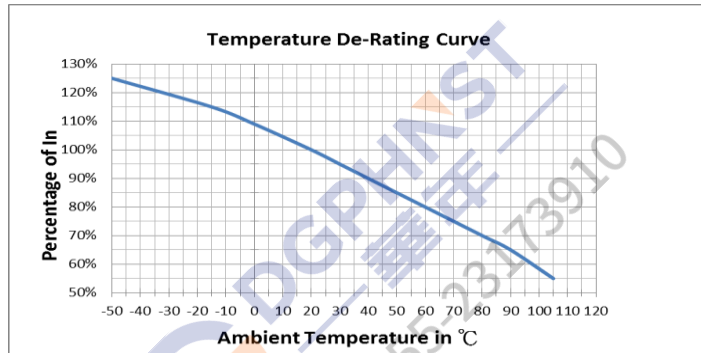

9-2 存儲條件 / Storage Conditions

在溫度+10°C ~ 60°C、相對濕度≤75%的密閉條件下可存放3年。

Under airtight in temperature+10°C ~ 60°C、relative humidity ≤75% can store 3 years.

在溫度+10°C ~ 60°C、相對濕度為95%的非露天下最多可存放30天。

Without dew in temperature+10°C ~ 60°C、relative humidity be 95% maximum value for 30days.

10. 安全認證及編號 / STANDARDS AND APPROVALS

WL25	cULus	E483392 (0.1~32A JFHR 8/2)
------	-------	-----------------------------

11. 安裝方式及條件 / INSTALLATION WAY AND PARAMETERS

11-1 螺絲安裝,提供其他安裝方式選擇

Stud-mount, optional for other installtion

11-2 建議客戶焊接參數 / Recommended Customer Soldering Parameters

波峰焊參數 / Wave Parameters:

錫爐溫度 / Solder Pot Temperature: 260±3°C

焊接時間 / Solder Dwell Time: 10s Max

手工焊參數 / Hand-Solder Parameters:

烙鐵溫度 / Solder Iron Temperature: 350±5°C

焊接時間 / Heating Time: 5 s Max

12. 包裝及數量 / Packing And Quantity

12-1 數量 / Quantity

規格 Specification	內小盒 / Inner small box	內大盒 / Inner big box	外箱 / Outer carton
WL25-XXX	-	100PCS	1800PCS
WL25-XXX-P1	10PCS		500PCS
WL25-XXX-BP	16PCS		896PCS

12-2 內盒/Inner box of packing

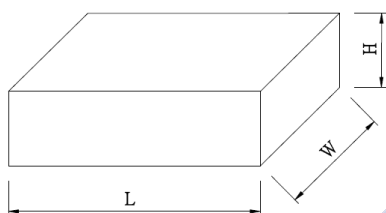

單位/Unit : mm

規格/Specification	L	W	H
WL25-XXX(small)	53±5	21±5	40±5
WL25-XXX(big)	115±5	110±5	45±5
WL25-XXX-P1	24.5±5	15±5	410±5
WL25-XXX-BP	57±5	48±5	70±5

12-3 外箱/Outer box of packing

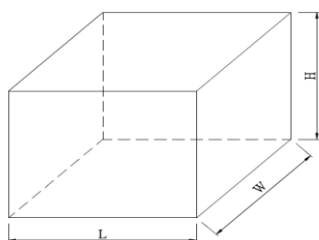

單位/Unit : mm

規格/Specification	L	W	H
WL25-XXX	380±5	245±5	200±5
WL25-XXX-P1	175±5	135±5	420±5
WL25-XXX-BP	380±5	245±5	200±5

13. 其他 / OTHERS

13-1 如果在使用中有超出本規格書的要求，必須經由雙方協商確認。

In the event that an impropriety is found beyond this specification, it shall be fixed by mutual agreement between the parties.

13-2 如果本規格書有不適當的情況，必須通過雙方協商並由本公司修改。

In the event that an impropriety is found in this specification, WALTER ELECTRONIC CO., LTD. shall amend it by mutual agreement between the parties.

版次	製作	確認	審核
第五版	侯愛珍	吳讓彬	Andrew